

# LICENCE

for

**DR2 AS/NZS 5139:2019, Electrical installations — Safety of battery systems for use with power conversion equipment**



To read the full licence agreement, click within the box above and scroll through using the scroll bar

# Draft

## Australian/New Zealand Standard™

Public Comment is invited for:

DR2 AS/NZS 5139:2019, *Electrical installations — Safety of battery systems for use with power conversion equipment*

Public Comment period:

Start date: 30 January 2019

Close date: 03 April 2019

To submit comments please use the following link:

<https://hub.standards.org.au/hub/public/listOpenCommentingPublication.action>

During their development process, Australian/New Zealand Standards are available in draft form during the public consultation period to allow any interests concerned with the application of the proposed Standard to review the draft and submit their comments.

This draft is liable to alteration. It is not to be regarded as an Australian/New Zealand Standard until finally issued as such by Standards Australia/Standards New Zealand.

Upon successful conclusion of the Public Comment period it is proposed to publish this Standard as AS/NZS 5139:201X.

**EDITORIAL NOTE:** A corrigendum has been added to this version of DR2 AS/NZS 5139:2019 after the How to submit comments page relating to Figures B.11, B.13, B.14 and B.16.

## How to submit comments

To submit comments on this proposed identical adoption of this Australian/New Zealand Standard:

### 1. Register

Register at the Standards Australia Standards Hub site:

<https://hub.standards.org.au/hub/public/listOpenCommentingPublication.action>

### 2. Enter

There are two submission options depending on the following:

Option A: If you have fewer than 10 comments, fill in the online form.

Option B: If you have more than 10 comments, download the Word form and type in your comments.

### 3. Submit

Submit comments by clicking on the blue 'Online Comment' button or 'Upload' button.

## Conditions for comment

Comments are welcome on the technical content, wording and general arrangement of the draft. How the requirements of this draft coordinate with other Standards is of particular importance and you are invited to point out any areas where changes or additions to this draft may be necessary. Editorial matters (i.e. spelling, punctuation, grammar, etc.) will be corrected before final publication.

Please provide supporting reasons and suggested wording for each comment. Where you consider that specific content is too simplistic, too complex or too detailed please provide an alternative.

If the proposed Standard is acceptable for Australia or New Zealand without change, an acknowledgement to this effect would be appreciated.

If you know of other persons or organizations that may wish to comment on this draft Australian/New Zealand Standard, please advise them of its availability. Copies of drafts and other publications are available from SAI Global at [www.saiglobal.com](http://www.saiglobal.com) or Standards New Zealand at [www.standards.govt.nz](http://www.standards.govt.nz).

Only comments submitted via the Standards Australia Standards Hub site before midnight on the closing date will be reviewed by the committee. The Hub automatically submits comments to the committee. Any other communication will not be considered by the committee.

At the expiry of the comment period, the committee responsible for the document is obliged to give serious consideration to all comments received. However, normally no acknowledgement of comment is sent.

## Corrigendum for Figures B.11, B.13, B.14, B.16

Due to a production error the warning signs in Figures B.11, B.13, B.14 and B.16 are incorrect and are to be replaced with the copies of the Figures displayed below for the purposes of DR AS/NZS 5139:2019.

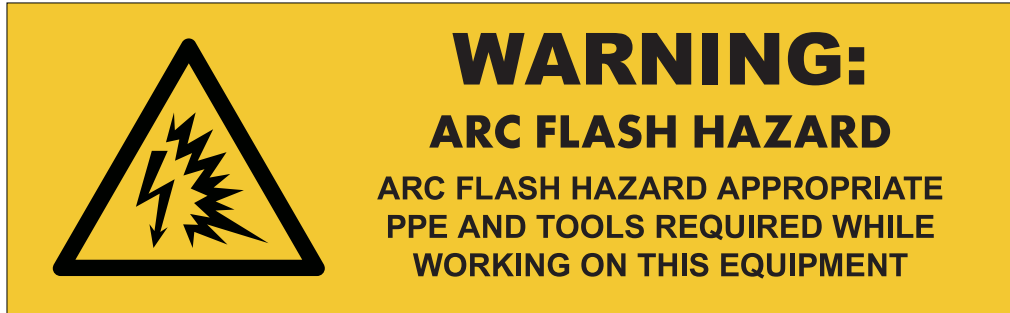

NOTE See [Clause 7.11](#).

Figure B.11 — Example sign for arc flash hazard



NOTE See [Clause 7.12.2](#).

Figure B.12 — Typical battery system isolator sign



NOTE See [Clause 7.12.3](#).

Figure B.13 — Typical battery system isolator sign



NOTE See [Clause 7.12.4](#).

Figure B.14 — Typical warning sign for isolation switches for battery systems above DVC-A

# BATTERY SYSTEM CIRCUIT BREAKER

NOTE See [Clause 7.13](#).

Figure B.15 — Typical sign for overcurrent device labelling



NOTE See [Clause 7.16](#).

Figure B.16 — Shutdown procedure notice

## Preface

This Standard was prepared by Joint Standards Australia/Standards New Zealand Committee EL-042, Renewable Energy Power Supply Systems and Equipment, to supersede AS 4086.2—1997, *Secondary batteries for use with stand-alone systems, Part 2: Installation and maintenance*.

AS 4086.2—1997 will also remain current for three months after the date of publication of this Standard and after that period it will be superseded by AS/NZS 5139:201X. Regulatory authorities that reference this Standard in regulation may apply these requirements at a different time. Users of this Standard should consult with these authorities to confirm their requirements.

The objective of this Standard is to provide manufacturers, system integrators, designers and installers of battery energy storage systems with the requirements for the safety and installation of battery systems connected to power conversion equipment for the supply of a.c. and/or d.c. power.

The installation of grid-connected energy storage systems, which include batteries, is a relatively new and growing market, and one in which there is a lack of definitive Standards.

Existing Standards for the design and installation of stationary battery systems were prepared for use with traditional lead-acid and nickel cadmium battery technology, and do not address recent production and application innovations and developments. These innovations include the following:

- (a) Newer battery technologies, including battery chemistry types other than lead-acid, such as lithium technologies (e.g. lithium ion, lithium iron phosphate), flow technologies (e.g. zinc bromine, vanadium redox flow), and hybrid ion technologies (e.g. aqueous). At this stage, this Standard does not cover high temperature batteries, such as NaNiCl batteries or sodium sulfur batteries.
- (b) New developments in interconnection equipment (e.g. multiple-mode inverters), which can result in batteries being continually connected to the grid, and also include photovoltaic (PV) or other energy sources as an integrated system.
- (c) Cheaper cost structures resulting in battery systems being utilized more widely and in many more applications, such as becoming more prevalent in domestic and residential electrical installations.

This Standard necessarily deals with existing types of energy storage, but is not intended to discourage innovation or to exclude materials, equipment and methods that may be developed in the future.

Due to the innovative nature of many new energy storage technologies and the lack of detailed information on their risks and failures, it is necessary to state that the material contained in this Standard is based on the best information available at the time of its preparation. During the process of the development of this Standard, these technologies are evolving and it is expected that this document will require ongoing updating to truly ensure safe installation and operation of battery energy storage systems. Revisions may be made from time to time in view of such developments, and amendments to this edition will be made when necessary.

This Standard contains a substantial number of informative components so that the level of knowledge and understanding in this new field of technology and its application is increased and so that this information can act as a guide for interested parties.

Standards Australia thanks the International Electrotechnical Commission (IEC) for permission to reproduce definitions from IEC Electropedia, available from [www.electropedia.org](http://www.electropedia.org), and IEC 62109-1:2010. These definitions are copyright of IEC, Geneva, Switzerland. All rights reserved. Further information on the IEC is available from [www.iec.ch](http://www.iec.ch). IEC has no responsibility for the placement and context in which the extracts and contents are reproduced by the author, nor is IEC in any way responsible for the other content or accuracy therein

The terms “normative” and “informative” have been used in this Standard to define the application of the appendix to which they apply. A “normative” appendix is an integral part of a Standard, whereas an “informative” appendix is only for information and guidance.

# Contents

<b>Preface</b> .....	<b>iii</b>
<b>Section 1 Scope and general</b> .....	<b>1</b>
1.1 Scope and application.....	1
1.1.1 Scope.....	1
1.1.2 Application.....	2
1.2 Normative references.....	2
1.3 Terms and definitions.....	4
<b>Section 2 Battery energy storage system (BESS) configurations</b> .....	<b>13</b>
2.1 General.....	13
2.2 Battery energy storage systems.....	13
2.2.1 Overview.....	13
2.2.2 Battery system chemistries.....	13
2.2.3 Battery systems.....	14
2.2.4 BESS: Key components.....	14
2.2.5 Battery system components.....	15
2.2.6 BESS: Typical configurations.....	15
2.3 BESS: Applications.....	18
2.3.1 Applications.....	18
2.3.2 System architectures.....	18
2.3.3 Electrical diagrams.....	18
<b>Section 3 Battery energy storage system hazards</b> .....	<b>23</b>
3.1 General.....	23
3.2 Hazards associated with a BESS.....	23
3.2.1 General.....	23
3.2.2 Hazard classification by battery type.....	23
3.2.3 Electrical hazard.....	24
3.2.4 Energy hazard.....	25
3.2.5 Fire hazard.....	28
3.2.6 Explosive gas hazard.....	29
3.2.7 Chemical hazard.....	29
3.2.8 Mechanical hazard.....	30
3.2.9 Toxic fume hazard.....	30
<b>Section 4 Pre-assembled integrated BESSs — Installation, commissioning and documentation</b> .....	<b>31</b>
4.1 General requirements.....	31
4.2 Installation requirements.....	31
4.2.1 General.....	31
4.2.2 Location.....	31
4.2.3 Environmental requirements.....	33
4.2.4 Protective against spread of fire.....	34
4.2.5 Pre-assembled integrated BESS room requirements.....	35
4.2.6 Seismic (earthquake) forces.....	36
4.3 Installation hazards.....	36
4.3.1 Electrical hazards.....	36
4.3.2 Energy hazard — Arc flash.....	37
4.3.3 Fire hazard.....	37
4.3.4 Explosive gas hazard.....	37
4.3.5 Chemical hazard.....	37
4.3.6 Mechanical hazard.....	37
4.3.7 Toxic fume hazard.....	38
4.4 System documentation, verification and commissioning.....	38
4.4.1 Documentation.....	38
4.4.2 Verification.....	39

PUBLIC COMMENTING DRAFT

4.4.3	Commissioning	40
<b>Section 5</b>	<b>Pre-assembled battery systems — Installation, commissioning and documentation</b>	<b>42</b>
5.1	General requirements for pre-assembled battery systems	42
5.2	Installation requirements	42
5.2.1	General	42
5.2.2	Location	42
5.2.3	Environmental requirements	44
5.2.4	Protection against the spread of fire	44
5.2.5	Pre-assembled battery system room requirements	46
5.2.6	Seismic (earthquake) forces	47
5.3	Installation hazards	47
5.3.1	Electrical hazards	47
5.3.2	Energy hazard — Arc flash	60
5.3.3	Fire hazard	61
5.3.4	Explosive gas hazard	61
5.3.5	Chemical hazard	61
5.3.6	Mechanical hazard	61
5.3.7	Toxic fume hazard	61
5.4	System documentation, verification and commissioning	62
5.4.1	Documentation	62
5.4.2	Verification	63
5.4.3	Commissioning	64
<b>Section 6</b>	<b>Battery systems and BESSs not covered by <a href="#">Sections 4 and 5</a> — Installation, commissioning and documentation</b>	<b>66</b>
6.1	General requirements	66
6.2	Installation of battery system	66
6.2.1	General	66
6.2.2	Location	66
6.2.3	Environmental requirements	68
6.2.4	Protection against the spread of fire	69
6.2.5	Battery system and BESS enclosure requirements	70
6.2.6	Battery system room requirements	72
6.2.7	Battery cell or module stands	74
6.2.8	Seismic (earthquake) forces	74
6.3	Installation hazards	75
6.3.1	Electrical hazards	75
6.3.2	Energy hazard	91
6.3.3	Fire hazard	94
6.3.4	Explosive gas hazard	97
6.3.5	Chemical hazard	101
6.3.6	Mechanical hazard	103
6.3.7	Toxic fume hazard	104
6.4	System documentation, verification and commissioning	105
6.4.1	Documentation	105
6.4.2	Verification	106
6.4.3	Commissioning	107
<b>Section 7</b>	<b>Labels and safety signage</b>	<b>108</b>
7.1	General	108
7.2	Requirements for signs and labels	108
7.3	Battery type general labelling	109
7.4	Signs for battery system location	109
7.5	Restricted access	109
7.6	Voltage and current	109
7.7	Safety data sheet (SDS)	110
7.8	Explosive gas hazard	110
7.9	Toxic fume hazard	110



PUBLIC COMMENTING DRAFT

7.10	Chemical hazard.....	110
7.11	Arc flash.....	110
7.12	Disconnection devices.....	110
	7.12.1 General.....	110
	7.12.2 Battery system isolation device.....	110
	7.12.3 Multiple isolation device.....	111
	7.12.4 Disconnectors for DVC-B and DVC-C systems.....	111
7.13	Overcurrent devices.....	111
	7.13.1 General.....	111
	7.13.2 Multiple overcurrent devices.....	111
	7.13.3 Fuse holders.....	111
7.14	Battery system cables.....	111
7.15	Segregation.....	112
7.16	Shutdown procedure.....	112
7.17	Battery labelling.....	112
7.18	Other equipment labelling.....	112
7.19	Spill containment.....	113
<b>Appendix A (informative) Decisive voltage classification (DVC)</b> .....		<b>114</b>
<b>Appendix B (informative) Safety signs</b> .....		<b>115</b>
<b>Appendix C (informative) Typical layout of battery rooms and stands</b> .....		<b>123</b>
<b>Appendix D (informative) Battery system enclosures examples for battery types classified as explosive gas hazards</b> .....		<b>127</b>
<b>Appendix E (informative) Typical layouts for location and barrier requirements</b> .....		<b>131</b>
<b>Appendix F (informative) Arc flash calculation</b> .....		<b>134</b>
<b>Appendix G (informative) Risk assessment</b> .....		<b>142</b>
<b>Appendix H (informative) Inspection and maintenance</b> .....		<b>153</b>
<b>Bibliography</b> .....		<b>156</b>

DRAFT

# Australian/New Zealand Standard

## Electrical installations—Safety of battery systems for use with power conversion equipment

### Section 1 Scope and general

#### 1.1 Scope and application

##### 1.1.1 Scope

This Standard sets out general installation and safety requirements for battery energy storage systems (BESSs), where the battery system is installed in a location such as a dedicated enclosure or room and is connected with power conversion equipment (PCE) to supply electric power to other parts of an electrical installation.

This Standard sets out the requirements from the battery system up to but not including the PCE. This Standard also applies to pre-assembled integrated battery energy storage systems, which also include PCE(s).

This Standard outlines the potential hazards that are associated with battery energy storage systems and their associated battery systems and specifies installation methods that minimize risks posed by these hazards.

This Standard is applicable for the following battery systems:

- (a) Nominal voltage between 12 V d.c. and 1500 V d.c.
- (b) Connected to either single or multiple PCEs.
- (c) Using secondary or rechargeable cells.
- (d) With a rated capacity equal to or greater than 1 kWh and no more than 200 kWh, at —
  - (i) C10 rating, for lead acid batteries; or
  - (ii) 0.1C, for lithium technologies; or
  - (iii) manufacturer's specified energy capacity, for other technologies.

Where an installation includes multiple battery energy storage systems, this Standard applies to each individual battery energy storage system if —

- (A) the total energy storage capacity is equal to or greater than 1 kWh; and
- (B) each individual BESS is no more than 200 kWh.

This Standard does not apply to battery systems in the following electrical installation types:

- (1) Premises with critical power continuity requirements (e.g. acute care hospitals, sub-station support and black start).
- (2) Telecommunication applications.
- (3) Electric vehicles.
- (4) Portable equipment.
- (5) Uninterruptible power systems (UPS) that are in accordance with AS 62040, Parts 1.1 and 1.2.
- (6) Transportable structures and vehicles that are in accordance with AS/NZS 3001.

NOTE 1 While this Standard applies to systems of up to 200 kWh, the general requirements of this Standard may be applied to larger installations.

NOTE 2 While this Standard applies for common BESS technologies, other storage technologies may be able to use the risk approach to assess the hazards and mitigations that apply to the different storage technologies, e.g. super capacitors.

### 1.1.2 Application

This Standard shall apply to battery systems that are constructed on site and used in conjunction with a PCE.

This Standard shall apply to the installation of pre-assembled battery systems used in conjunction with a PCE. The manufacturing of pre-assembled battery systems does not form part of this Standard where these products have been type tested and shown to conform to applicable product Standards.

This Standard shall apply to the installation of the pre-assembled integrated BESS. The manufacturing of pre-assembled integrated BESS does not form part of this Standard where these products have been type tested and shown to conform to applicable product Standards.

Installation, commissioning and documentation requirements are specified for particular equipment in this Standard as follows:

- (a) Pre-assembled integrated battery energy storage systems (BESSs) — in [Section 4](#).
- (b) Pre-assembled battery system equipment — in [Section 5](#).
- (c) Battery systems and BESSs not conforming to *Best Practice Guide: battery storage equipment — Electrical Safety Requirements* — in [Section 6](#).

This Standard shall be read in conjunction with AS/NZS 3000.

This Standard is applicable for both grid connected inverter energy systems and stand-alone power systems installations. When the installation of a battery system forms part of a system that is connected to the grid, this Standard shall be read in conjunction with the AS/NZS 4777 series. When the installation of a battery system forms part of a stand-alone power system, this Standard shall be read in conjunction with the AS/NZS 4509 series.

Local government, Australian National Construction Code (NCC) and New Zealand Building Code requirements for buildings may also apply where a BESS is installed.

## 1.2 Normative references

The following documents are referred to in the text in such a way that some or all of their content constitutes requirements of this document.

NOTE Documents referenced for informative purposes are listed in the Bibliography.

AS 3731, *Stationary batteries (series)*

AS 62040.1.1, *Uninterruptible power systems (UPS), Part 1.1: General and safety requirements for UPS used in operator access areas*

AS 62040.1.2, *Uninterruptible power systems (UPS), Part 1.2: General and safety requirements for UPS used in restricted access locations*

AS/NZS 1170.1, *Structural design actions, Part 1: Permanent, imposed and other actions*

AS/NZS 1170.2, *Structural design actions, Part 2: Wind actions*

AS 1170.4, *Structural design actions, Part 4: Earthquake actions in Australia*

AS/NZS 1680.1, *Interior and workplace lighting, Part 1: General principles and recommendations*

AS/NZS 3000, *Electrical installations (known as the Australian/New Zealand Wiring Rules)*

AS/NZS 3008.1.1, *Electrical installations — Selection of cables, Part 1.1: Cables for alternating voltages up to and including 0.6/1 kV — Typical Australian installation conditions*

AS/NZS 3008.1.2, *Electrical installations — Selection of cables, Part 1.2: Cables for alternating voltages up to and including 0.6/1 kV — Typical New Zealand conditions*

AS/NZS 4029.1, *Stationary batteries — Lead-acid, Part 1: Vented type*

AS/NZS 4029.2, *Stationary batteries — Lead acid, Part 2: Valve regulated type*

AS/NZS 4509.1, *Stand alone power systems, Part 1: Safety and installation*

AS/NZS 4777.1, *Grid connection of energy systems via inverters, Part 1: Installation requirements*

AS/NZS 4777.2, *Grid connection of energy systems via inverters, Part 2: Inverter requirements*

AS/NZS 5000.1, *Electric cables — Polymeric insulated, Part 1: For working voltages up to and including 0.6/1 (1.2) kV*

AS/NZS 5000.2, *Electric cables — Polymeric insulated, Part 2: For working voltages up to and including 450/750 V*

AS/NZS 5033, *Installation and safety requirements for photovoltaic (PV) arrays*

AS/NZS 60898.2, *Circuit-breakers for overcurrent protection for household and similar installations, Part 2: Circuit-breakers for a.c. and d.c. operation (IEC 60898 2 Ed. 1.1 (2003) MOD)*

AS/NZS IEC 60947.1, *Low-voltage switchgear and control gear, Part 1: General rules*

AS 60947.3, *Low-voltage switchgear and control gear, Part 3: Switches, disconnectors, switch-disconnectors and fuse-combination units (IEC 60947 3:2015 (ED.3.2) MOD)*

NZS 4219, *Seismic performance of engineering systems in buildings*

IEC 60269-1, *Low-voltage fuses, Part 1: General requirements*

IEC 60269-3, *Low-voltage fuses, Part 3: Supplementary requirements for uses for use by unskilled persons (fuses mainly for household or similar applications) — Examples of standardized systems of fuses A to F*

IEC 60529, *Degrees of protection provided by enclosures (IP Code)*

IEC 60896, *Stationary lead-acid batteries (series)*

AS/NZS IEC 60947-2, *Low-voltage switchgear and control gear, Part 2: Circuit-breakers*

IEC 62109-1, *Safety of power converters for use in photovoltaic power systems, Part 1: General requirements*

IEC 62619, *Secondary cells and batteries containing alkaline or other non-acid electrolytes — Safety requirements for secondary lithium cells and batteries, for use in industrial applications*

IEC 62930, *Electric cable for photovoltaic systems with a voltage rating of 1,5 kV DC*

*Best Practice Guide: battery storage equipment — Electrical Safety Requirements V 1.0 (2018)*<sup>1)</sup>

1) This document was the result of a collaboration between the Clean Energy Council, the Australian Industry Group, the Consumer Electronics Suppliers Association, CSIRO and the Smart Energy Council and may be accessed through: <http://www.batterysafetyguide.com.au/>.

### 1.3 Terms and definitions

For the purpose of this Standard, the following definitions and those of AS/NZS 3000 apply. If no definition is given for a term, the definition given in Electropedia (also known as the “IEV” Online) applies. Electropedia is copyright material of the International Electrotechnical Commission and may be accessed through [www.electropedia.org](http://www.electropedia.org).

#### 1.3.1

**accessible, readily**

capable of being reached quickly and without climbing over or removing obstructions, or using a movable ladder, and not more than 2 m above the ground, floor or platform

#### 1.3.2

**accessories**

those items supplied with a battery, battery module or battery system to facilitate the continued operation of the battery system

Note 1 to entry: Such accessories include distilled water in containers, connectors, connecting bolts and nuts, and hydrometers.

#### 1.3.3

**adjacent**

next to or adjoining without obstruction and within arm's reach

#### 1.3.4

**arc flash**

electrical explosion or discharge, which occurs between electrified conductors during a fault or short-circuit condition

#### 1.3.5

**arc flash incident energy**

measurement applied to determine the available incident arc flash energy at a specified distance originating from an arc flash. This measurement is used to determine the level of personal protection equipment (PPE) and the relevant arc flash protection boundary

#### 1.3.6

**arc flash protection boundary**

boundary marked by the distance from electrical equipment at which the arc flash incident energy is equal to 1.2 cal/cm<sup>2</sup>. Correct personal protective equipment (PPE) is required within this boundary to protect from burns

Note 1 to entry: PPE is rated in calories (symbol: cal), therefore the unit joules is not used in this application.

#### 1.3.7

**assembled**

having connected together the separate component parts of a battery energy storage system (BESS)

#### 1.3.8

**authorized person**

person in charge of the premises, or the licensed electrical contractor or electrician or other competent person appointed or selected by the person in charge of the premises to perform certain duties associated with the BESS or battery system installation on the premises

#### 1.3.9

**auxiliary equipment/battery equipment**

equipment required for supporting different battery technologies and associated battery infrastructure. May include pumps, storage tanks, fire suppression, communications equipment, and any other equipment required for the battery system to operate, excluding BMM and BMS

**1.3.10****available, readily**

capable of being reached for inspection, maintenance or repairs without necessitating the dismantling of structural parts, cupboards, benches or the like

**1.3.11****battery**

unit consisting of one or more energy storage cells connected in series, parallel or series parallel arrangement

**1.3.12****battery bank**

batteries or battery modules connected in series and/or parallel to provide the required voltage, current and storage capacity within a battery system, and meet the requirements of associated power conversion equipment (PCE)

**1.3.13****battery energy storage system****BESS**

consists of PCE, battery system(s), and isolation and protection devices. Where provided, it also includes auxiliary battery equipment, battery cables, battery management module(s), and battery management system

**1.3.14****battery energy storage system enclosure**

dedicated enclosure containing all the components of a battery energy storage system including, but not limited to, PCE, battery system(s) and all the necessary auxiliary equipment that is compatible with the installation location and the associated BESS components. The enclosure may also house ancillary equipment related to the photovoltaic (PV) array connection or diesel generator connection

**1.3.15****battery management module****BMM**

distributed battery and battery module devices that feed into the BMS and are generally part of the electronics on an individual cell or module

**1.3.16****battery management system****BMS**

electronic system that monitors and manages a battery or battery system's electric and thermal states enabling it to operate within the safe operating region of the particular battery. The BMS provides communications between the battery or battery system and the PCE and potentially other connected devices (e.g. vents or cooling)

Note 1 to entry: The BMS monitors cells, battery or battery modules to provide protective actions for the battery system in the case of overcharge, overcurrent, over discharge, overheating, overvoltage and other possible hazards that could occur. Additional BMS functions may include active or passive charge management, battery equalization, thermal management, specific messaging or communications to the PCE regarding charge rates and availability.

**1.3.17****battery module**

one or more cells linked together. May also have incorporated electronics for monitoring, charge management and/or protection

**1.3.18****battery short-circuit current**

potential maximum fault current able to be delivered from a battery under the condition of shorting the terminals



**1.3.19****battery string**

batteries or battery modules connected in series

**1.3.20****battery system**

system comprising one or more cells, modules or batteries. Depending on the type of technology, the battery system may include one or multiple battery management system/s and auxiliary supporting and/or protective equipment for the system. This does not include the PCE

**1.3.21****battery system enclosure**

dedicated enclosure containing the battery system, including associated battery system components, and which is compatible with the installation location

Note 1 to entry: Preassembled battery systems may already include a suitable enclosure.

**1.3.22****battery system room**

dedicated room for the battery system and the associated battery system components. May also contain all the components of a battery energy storage system including, but not limited to, PCE, battery system(s) and all the necessary auxiliary equipment. The room may also house ancillary equipment related to the PV array connection or diesel generator connection

**1.3.23****cable, current-carrying capacity****CCC**

maximum continuous current at which a conductor will not overheat and cause permanent damage to the conductor insulation. It is affected by conductor cross-sectional area, cable insulation material and the method of cable installation

Note 1 to entry: For further information, see AS/NZS 3008.1.1 or AS/NZS 3008.1.2, as appropriate.

**1.3.24****capacity**

**C**  
electric charge which a cell or battery can deliver under specified discharge conditions

Note 1 to entry: The SI unit for electric charge, or quantity of electricity, is the coulomb (1 C = 1 A·s) but in practice, capacity is usually expressed in ampere hours (Ah).

[SOURCE: IEC 482-03-14]

**1.3.25****cell**

basic functional unit, consisting of an assembly of electrodes, electrolyte, container, terminals and usually separators, that is a source of electric energy obtained by direct conversion of chemical energy

[SOURCE: IEC 482-01-01]

**1.3.26****charging**

operation during which a secondary cell or battery is supplied with electric energy from an external circuit which results in chemical changes within the cell and thus the storage of energy as chemical energy

Note 1 to entry: Charge is usually measured in ampere-hours.

[SOURCE: IEC 482-05-27]

**1.3.27****combustion by-products**

secondary products produced by burning materials within battery systems

Note 1 to entry: For combustion by-products refer to the safety data sheet (SDS) specific to the battery type.

**1.3.28****competent person**

person who has acquired knowledge and skill, through training, qualifications, experience, or a combination of these, and which enables that person to correctly perform the task required

**1.3.29****decisive voltage classification****DVC**

determination of the highest voltage, which occurs continuously between any two arbitrary live parts of the battery system, battery modules or the PCE during worst-case, rated operating conditions when used as intended

**1.3.30****dedicated room or enclosure**

room or enclosure exclusively assigned to the use of equipment specified as part of the battery system, BESS or power system (including energy source connections)

**1.3.31****deflection**

degree to which a structural component is displaced under a load

**1.3.32****discharging**

operation during which a battery delivers current to an external circuit by the conversion of chemical energy to electric energy

**1.3.33****electrical hazard**

potential source of harm when electric energy is present in an electrical installation (harm relates to injury to persons and/or damage to electrical installations)

**1.3.34****electrical installation, domestic**

electrical installation in a private dwelling or that portion of an electrical installation associated solely with a flat or living unit

**1.3.35****electrical installation, residential**

electrical installation or that portion of an electrical installation associated with a living unit or units

**1.3.36****electrolyte**

liquid or solid substance containing mobile ions which will render the substance ionically conductive, for example, sulfuric acid ( $H_2SO_4$ ) in lead-acid batteries, sodium hydroxide (NaOH) in nickel-cadmium batteries and zinc bromine ( $ZnBr_2$ ) in zinc bromine batteries

**1.3.37****explosive gas hazard**

mixture with air, under atmospheric conditions, of flammable substances in the form of gas or vapour which, after ignition, permits self-sustaining flame propagation which may cause harm to people, property, or the environment

[SOURCE: IEV 426-01-07]



**1.3.38****fire hazard**

potential source of physical injury or damage to persons or property resulting from burns due to the ignition and combustion of flammable materials present in the battery or battery system or enclosure

**1.3.39****fire hazard level 1**

fire occurring within a battery system, where the fire is self-sustaining

**1.3.40****fire hazard level 2**

fire occurring within a battery system, where the fire is not self-sustaining

**1.3.41****fire separation**

wall or barrier having a specified fire resistance level for the purpose of preventing the spread of fire

**1.3.42****habitable room**

room associated with a domestic or residential electrical installation used for normal living activities (for example, a bedroom, living room, lounge room, music room, television room, kitchen, dining room, sewing room, study, playroom, family room, home theatre and sunroom)

**1.3.43****hazard**

potential source of harm

(SOURCE: IEC 60364-4-41)

**1.3.44****horizontally mounted cell**

cell designed to operate with its terminals and valves mounted on a vertical surface (see [Figure 1.1](#))

**1.3.45****inter cell connections**

those connections made between adjacent cells in a single row

**1.3.46****inter-row connections**

those connections made between rows of cells

**1.3.47****inter-string protection**

devices inserted between adjacent cells within a string for the purposes of isolation and/or overcurrent protection

**1.3.48****lithium ion technologies**

secondary battery technology containing a lithium salt electrolyte. Different battery types may have different material compositions for each of the anode, cathode and electrolyte

**1.3.49****mechanical hazard**

factors which may cause harm due to the mechanical properties of products/product parts

**1.3.50****nominal cell voltage**

$V_n$

manufacturer's stated voltage, which is the steady state disconnected charged voltage of a cell

### 1.3.51 nominal system voltage

$V_{\text{sys}}$

calculated from the cell nominal voltage ( $V_n$ ) and the number of cells in series ( $n$ ) as follows:

$$V_{\text{sys nominal}} = V_n \times n$$

### 1.3.52 partial state of charge operation

operation whereby batteries do not typically cycle between full SOC and depletion, and are then fully recharged. Partial state of charge relates to a considerable variation in operation generally between 20% SOC and 90% SOC

### 1.3.53 personal protection equipment

PPE

specialized clothing or equipment worn by personnel for protection against safety and health hazards

### 1.3.54 port (of PCE)

location giving access to a device or network where electromagnetic energy or signals may be supplied or received or where the device or network variables may be observed or measured

[SOURCE: IEC 62109-1:2010, 3.64.]

### 1.3.55 power conversion equipment

PCE

electrical device converting and/or manipulating one kind of electrical power from a voltage or current source into another kind of electrical power with respect to voltage, current and/or frequency

Note 1 to entry: Examples include but are not limited to d.c./a.c., inverters, d.c./d.c. converters and charge controllers.

Note 2 to entry: Battery management systems are not considered to be PCEs for the purpose of this Standard.

### 1.3.56 power conversion equipment, non-separated

PCE with no electrical separation between the input and output circuits

Note 1 to entry: An example of a non-separated PCE is a transformerless (non-isolated) inverter.

### 1.3.57 power conversion equipment, separated

PCE where electrical separation is provided by either of the following methods:

- (a) PCE with simple electrical separation between the input and output circuits in accordance with AS/NZS 3000.
- (b) PCE that is only used in series with another device that provides simple electrical separation between input and output in accordance with AS/NZS 3000 or a minimum of basic insulation separation in accordance with a product safety standard applicable to device providing electrical separation, e.g. a transformer

Note 1 to entry: Where a non-separated PCE is required to be used only in series with a dedicated isolation transformer, the combination may be treated as a separated PCE. Other configurations require analysis at the system level and are beyond the scope of this Standard, however the principles in this Standard may be applied.

**1.3.58****simple electrical separation**

electrical separation, as described in **AS/NZS 3000**, that has insulation of not less than 1 M $\Omega$ , when tested at a voltage of 500 V d.c

**1.3.59****pre-assembled battery system**

system comprising one or more cells, modules or battery systems, and/or auxiliary supporting equipment. Depending on the type of technology, the battery system may include a battery management system. Pre-assembled battery systems may come in a dedicated battery system enclosure

Note 1 to entry: Pre-assembled lithium based battery systems that comprise pre-assembled battery system equipment that conforms to the *Best Practice Guide: battery storage equipment — Electrical Safety Requirements*, and include a battery management system and a dedicated enclosure as integral parts of the equipment.

**1.3.60****pre-assembled integrated BESS**

battery energy storage system equipment that is manufactured as a complete, pre-assembled integrated package. The equipment is supplied in an enclosure with the PCE, battery system, battery management system, protection device and any other required components as determined by the equipment manufacturer

Note 1 to entry: A pre-assembled BESS may be delivered in separate modular parts and assembled on site.

Note 2 to entry: Pre-assembled lithium based battery energy storage system (BESS) equipment that conform to the *Best Practice Guide: battery storage equipment — Electrical Safety Requirements* are a pre-assembled integrated BESS when installed.

**1.3.61****prospective fault current**

current that would flow in the circuit during short-circuit fault conditions, if each main current path of the switching device and of the overcurrent protective device, if any, were replaced by a conductor of negligible impedance

[SOURCE: IEC 442-01-47 (MOD)]

**1.3.62****reasonably practicable**

that which is, or was at a particular time, reasonably able to be done to ensure health and safety, taking into account and weighing up all relevant matters including —

- (a) the likelihood of the hazard or the risk occurring;
- (b) the degree of harm that might result from the hazard or the risk;
- (c) what the persons concerned know, or ought reasonably to know, about the hazard or risk and ways of eliminating or minimising the risk;
- (d) the availability and suitability of ways to eliminate or minimize the risk; and
- (e) after assessing the extent of the risk and the available ways of eliminating or minimizing the risk, the cost associated with the available ways of eliminating or minimizing the risk, including whether the cost is grossly disproportionate to the risk

**1.3.63****risk**

possibility that harm (death, injury or illness) might occur when exposed to a hazard

Note 1 to entry: Risk is often expressed in terms of a combination of the consequences of an event (including changes in circumstances) and the associated likelihood of occurrence.

**1.3.64****risk assessment**

overall process comprising a systematic use of available information to identify hazards and to estimate the risk (risk analysis), and determine what and how control measures may reduce the residual risk, and to determine whether the tolerable risk has been achieved (risk evaluation)

**1.3.65****safety data sheet****SDS**

document that provides critical information about hazardous chemicals

Note 1 to entry: Refer to Safe Work Australia or WorkSafe New Zealand for further information.

**1.3.66****sealed valve-regulated cell**

cell that is closed under normal conditions, but which has an arrangement that allows the escape of gas if the internal pressure exceeds a predetermined value

**1.3.67****secondary cell**

cell that is designed to be electrically recharged

(SOURCE: IEC 482-01-03)

**1.3.68****service life**

total period of useful life of a cell or a battery in operation. For secondary cells and batteries, the service life may be expressed in time, number of charge/discharge cycles, capacity in ampere hours (Ah) or percentage of capacity

**1.3.69****shall**

indicates that a statement is mandatory

**1.3.70****short-circuit**

when a fault of negligible impedance occurs between live conductors having a difference in potential

**1.3.71****should**

indicates a recommendation

**1.3.72****shroud**

insulated cover to protect the terminals and inter-cell connectors from inadvertent contact by personnel and accidental short-circuiting, and may provide protection against corrosion

**1.3.73****stand-alone power systems****SPS**

systems that are not connected to the power distribution systems of an electricity entity/distributor. Stand-alone systems are supplied with power from one or more of a number of sources, including, but not limited to, a photovoltaic array, a wind turbine generator, a micro-hydro generator and a motor-generator set

**1.3.74****state of charge****SOC**

charge available in a battery or battery system expressed as a percentage of the rated capacity of the battery or battery system

PUBLIC COMMENTING DRAFT

**1.3.75**

**state of health**

ability of a battery system to store and deliver energy compared to its original rated capacity

**1.3.76**

**terminal/terminal post**

part provided for the connection of a cell or a battery to external conductors

**1.3.77**

**tiered stand**

stand on which rows of containers are placed above containers of the same or another battery

**1.3.78**

**toxic fumes**

gas or vapour classified as poisonous or dangerous for people to contact or inhale

**1.3.79**

**vertically mounted cell**

cell designed to operate with its terminals and valves mounted on its upper horizontal surface (see [Figure 1.1](#))

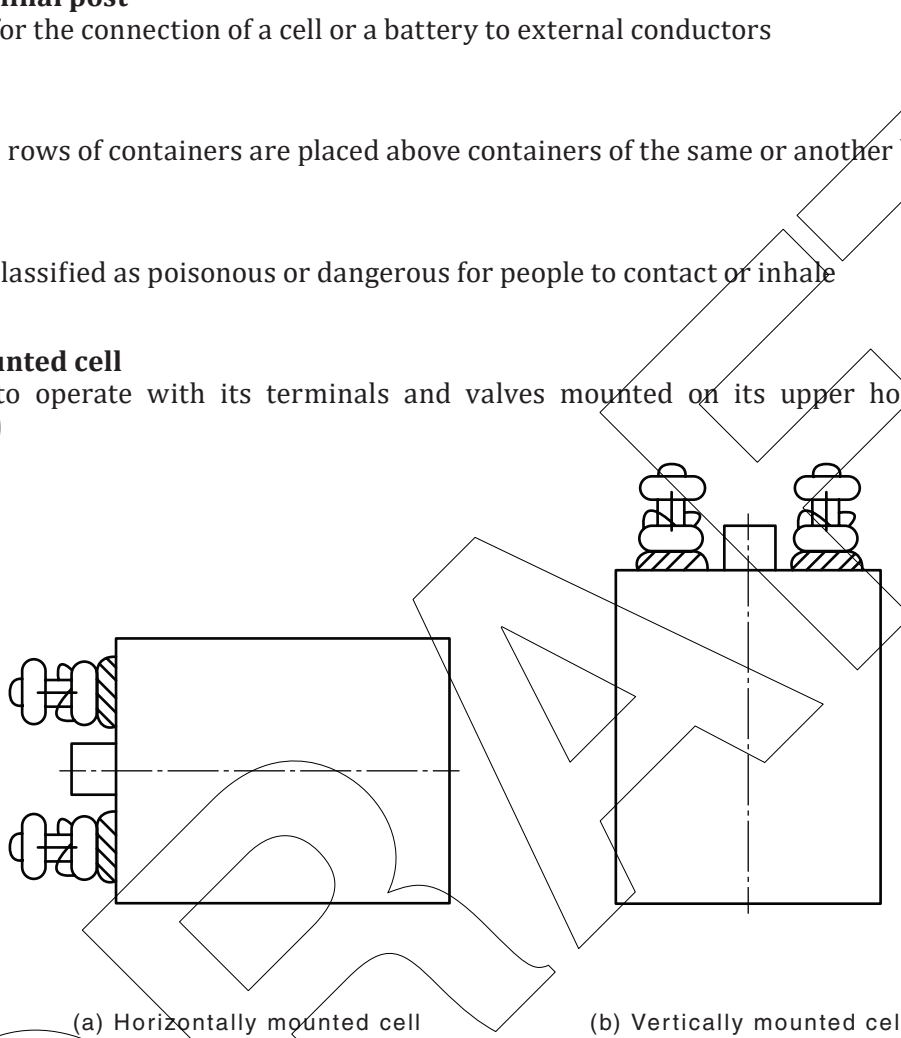

(a) Horizontally mounted cell

(b) Vertically mounted cell

NOTE This is an example of a cell showing the orientation. Other types of cell are available.

**Figure 1.1 — Cell orientation**

## Section 2 Battery energy storage system (BESS) configurations

### 2.1 General

Battery energy storage systems (BESS) are used to supply power to an application circuit.

[Figure 2.1](#) illustrates the general functional configuration of a battery energy storage system.

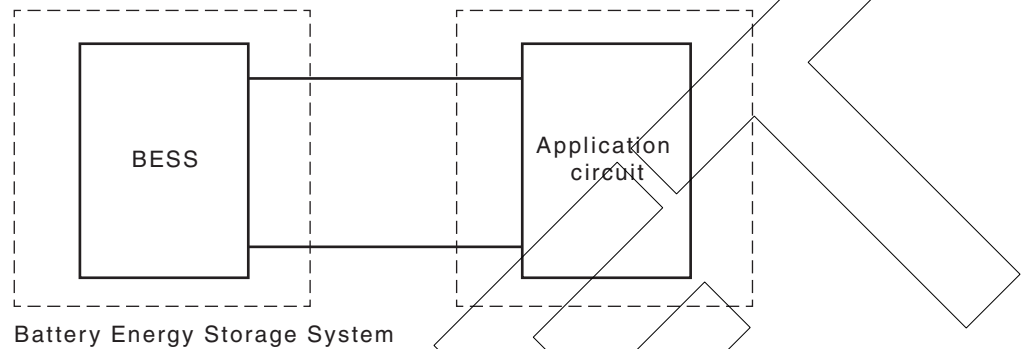

**Figure 2.1 — General functional configuration of a battery energy storage system**

### 2.2 Battery energy storage systems

#### 2.2.1 Overview

There are many different forms of battery energy storage system. The following list comprises examples of factors that affect the BESS design and installation requirements:

- (a) Battery system voltage.
- (b) Inverter port classification and configuration.
- (c) Battery system earthing arrangements.
- (d) Battery short circuit current/prospective fault current.
- (e) Battery system capacity.
- (f) Battery system chemistry.
- (g) Available access to the battery system, e.g. location restrictions for battery access, enclosure aspects.
- (h) BESS application requirements.
- (i) Average ambient temperature at battery location.

#### 2.2.2 Battery system chemistries

The following types of battery system chemistries are considered in the provisions of this Standard:

- (a) Lead acid.
- (b) Nickel alkaline.
- (c) Lithium ion.
- (d) Flow.
- (e) Hybrid ion.

NOTE The general provisions of this Standard may be applied to other battery system chemistries provided all the hazards listed in [Section 3](#), as well as any specific hazards related to that chemistry type, are accounted for. The electrical installation requirements of this Standard may be applied for these other battery system chemistries.

Any individual battery system shall be made up of only one type of technology or chemistry. Where battery systems of different types are used within one BESS, they shall be connected to separate ports or separate PCEs. This is to manage the different charging and discharging of these battery systems independently.

### 2.2.3 Battery systems

Battery systems may incorporate numerous devices in addition to the actual battery cell/s, including battery protection devices (these may be fuses or thermal devices that protect against short-circuit at the terminals), battery management modules, battery management systems, pumps, thermal management devices and fire suppression devices.

For the purpose of protection and disconnection device requirements, the electrical output of a battery system is defined at a point where the voltage is that of the d.c. operating voltage of the complete battery system. For some battery types, the battery system comprises one single string of the battery type, for example lead acid batteries and flow batteries. For some technologies, a battery system may comprise battery modules in series and parallel that are connected to a battery management system. The electrical output is on the output terminals of the battery management system.

Selection of a battery system or its subsets should take into account (but not be limited to) the following:

- (a) Compatible PCE.
- (b) Expected operational characteristics (maximum charge and discharge currents; rated capacity and timeframe for typical charge and discharge events; potential for partial state of charge operation).
- (c) Expected service life.
- (d) Available installation location including environmental factors.
- (e) Maximum acceptable nominal system voltage.
- (f) Additional hazard issues (see [Clause 3.2](#)).
- (g) Service provisions and ability to replace components.

### 2.2.4 BESS: Key components

BESSs generally comprise the following components:

- (a) Power conversion equipment (PCE).
- (b) Battery connection and interface (protection, accessories, etc.).
- (c) Battery system.

[Figure 2.2](#) illustrates the main components of a BESS.

PUBLIC COMMENTING DRAFT

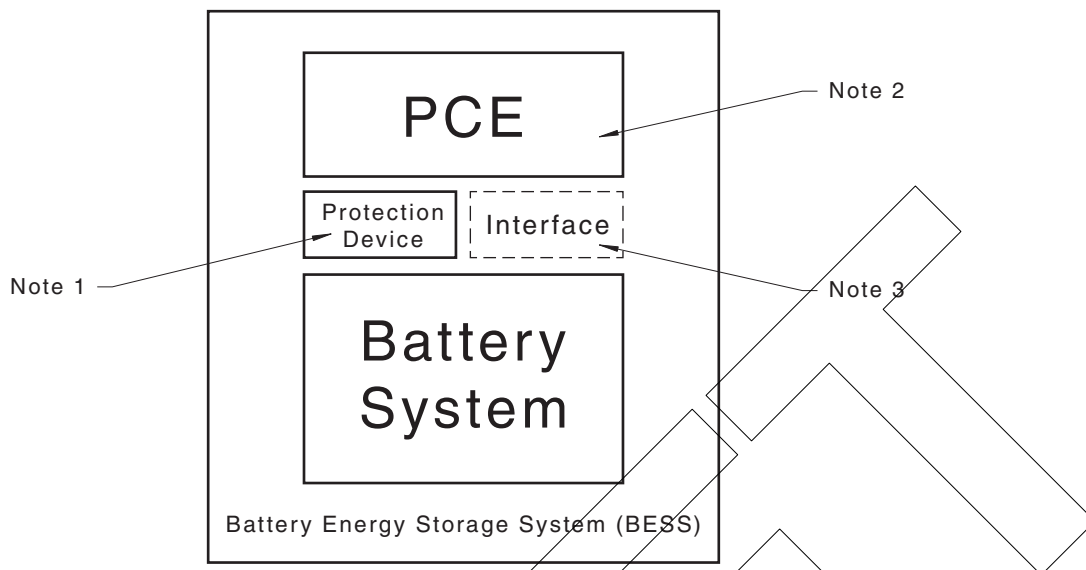

NOTE 1 Overcurrent protection device and isolation device.

NOTE 2 Power conversion equipment may consist of one or multiple PCEs.

NOTE 3 The interface may be for communications and/or monitoring.

**Figure 2.2 — Main components of a battery energy storage system**

**2.2.5 Battery system components**

Figure 2.3 illustrates some possible components of a battery system.

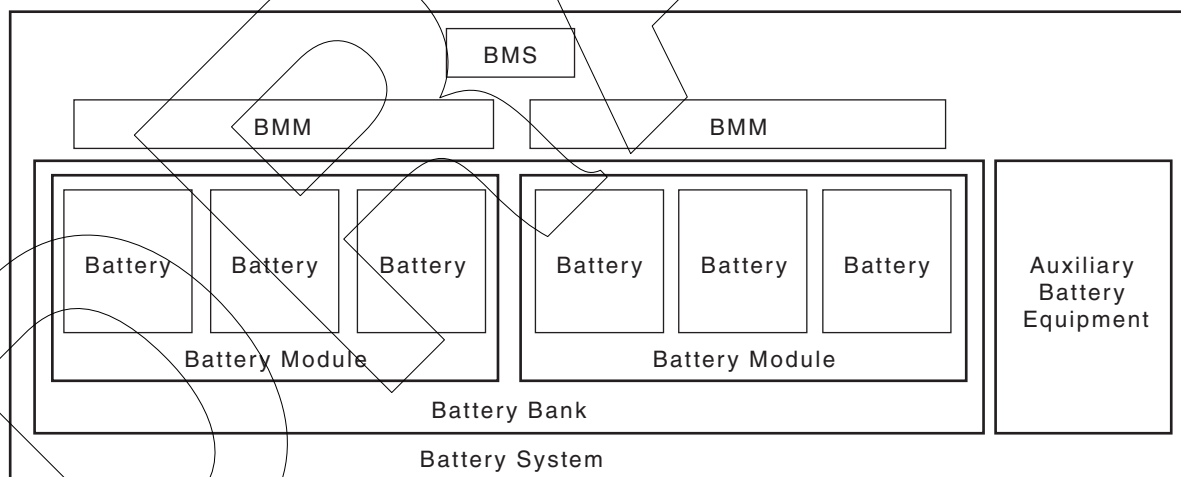

**Figure 2.3 — Typical components of battery system**

**2.2.6 BESS: Typical configurations**

This Clause applies to all BESSs. Figures 2.4 to 2.7 illustrate a number of available battery system types that may form part of a BESS.

Figure 2.4 is an example of a BESS with battery system comprising individual battery cells (e.g. lead acid or nickel cadmium) connected in series without the need for any battery management system.



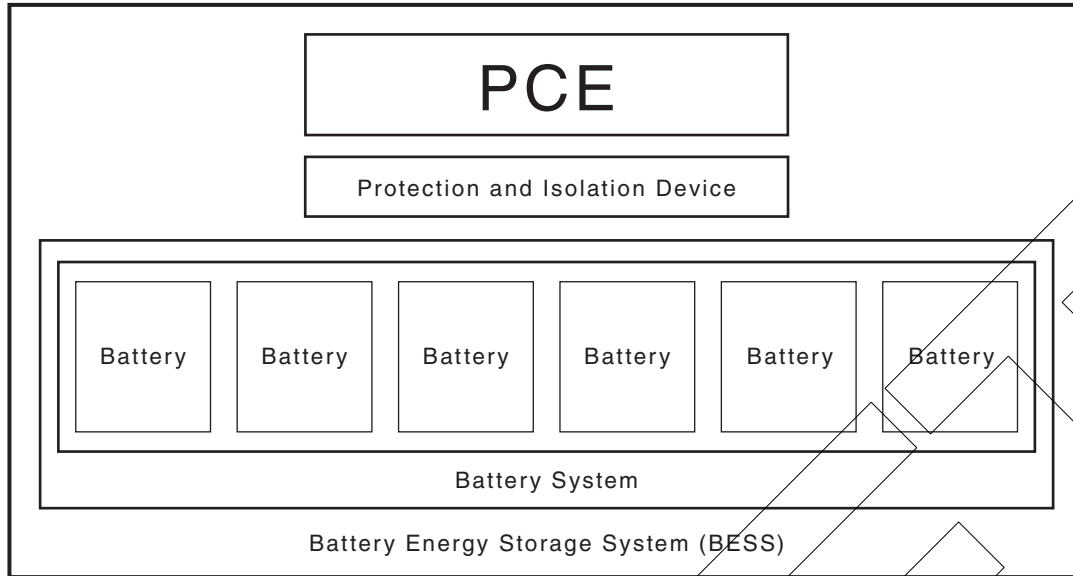

**Figure 2.4 — Typical BESS with battery system comprising individual battery cells and no battery management system (e.g. typical lead acid system)**

Figure 2.5 is an example of a BESS with battery system comprising a number of lithium ion battery modules in parallel and/or series with the required battery management system.

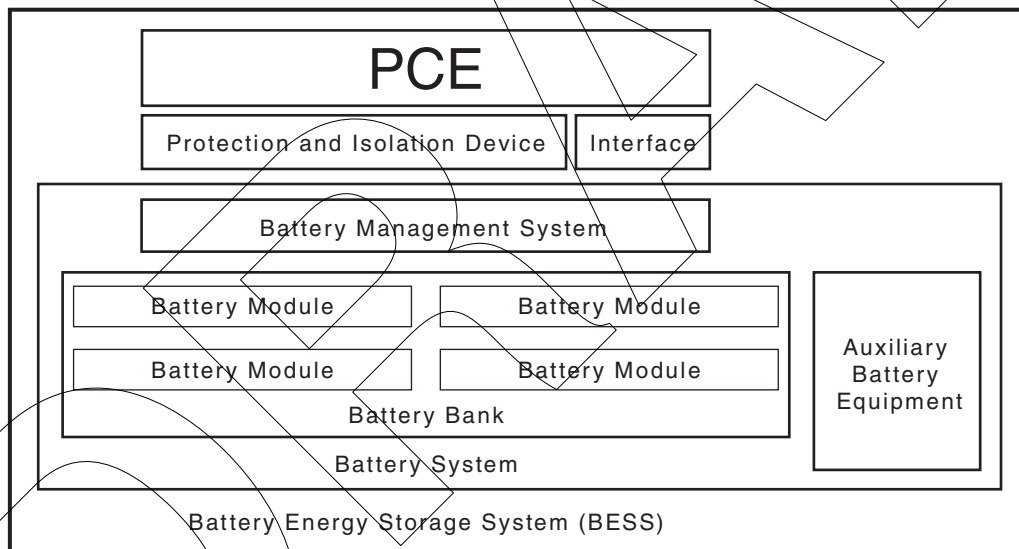

**Figure 2.5 — Typical BESS with battery system comprising lithium ion battery modules**

Figure 2.6 is an example of a BESS with battery system comprising individual lithium ion batteries, each having their own separate circuit board for all monitoring and/or balancing and interconnected with the battery management system.

Auxiliary equipment as shown in this figure may include devices such as battery system alarms or fire suppression systems, or items such as inbuilt cooling systems and specific battery system communication devices.

PUBLIC COMMENTING DRAFT

PUBLIC COMMENTING DRAFT

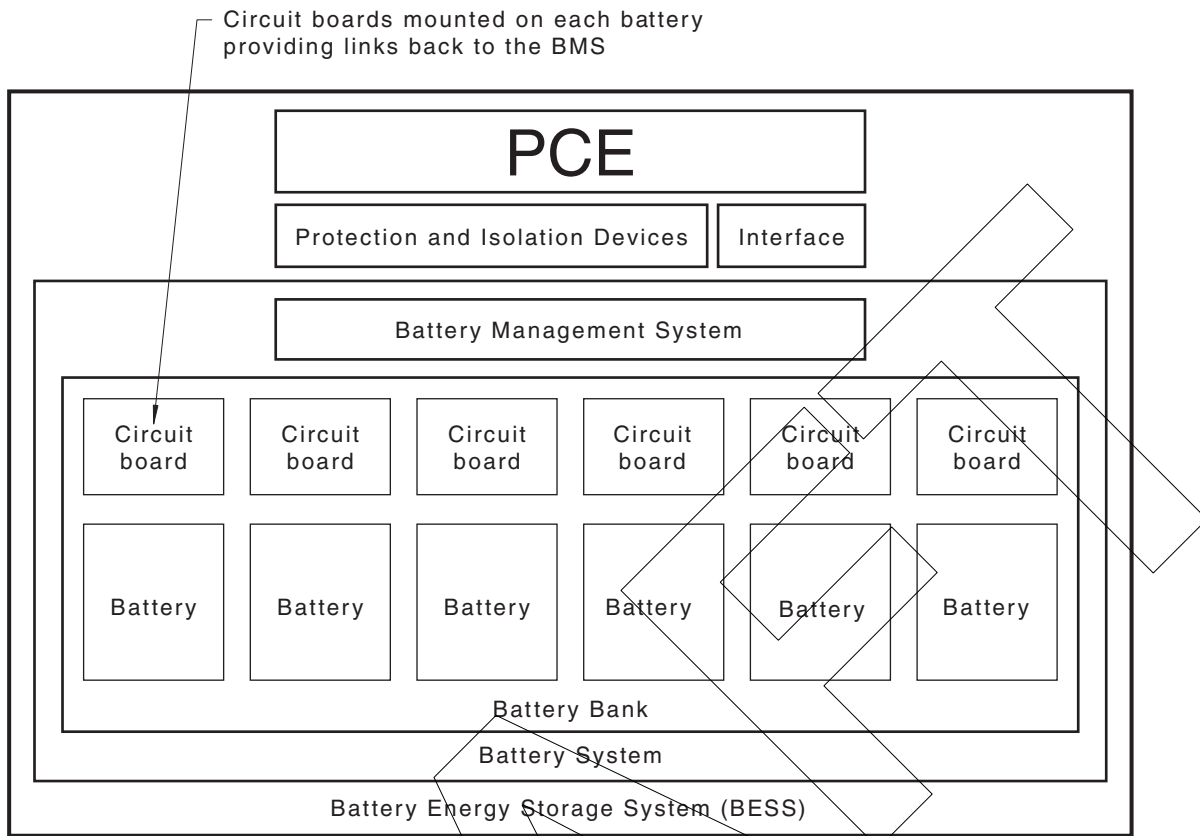

**Figure 2.6 — Typical BESS with battery system comprising individual lithium ion batteries, each having their own circuit board interconnected to a battery management system**

Figure 2.7 shows a BESS with a battery system comprising a flow battery module, auxiliary equipment and battery management system. Typical auxiliary equipment in this case may include pumps, leak detection alarms, pump controls and protection for auxiliaries.

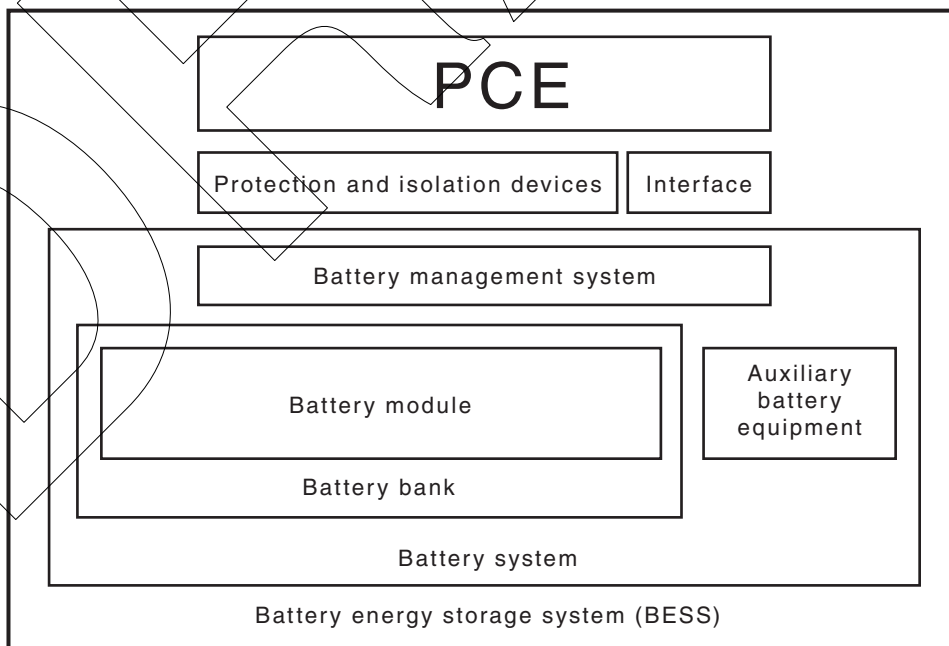

**Figure 2.7 — Typical BESS with battery system comprising flow battery module, auxiliary equipment and battery management system**

## 2.3 BESS: Applications

### 2.3.1 Applications

The following types of BESS are covered by this Standard:

- (a) BESS comprising PCE connected to d.c. application circuit.
- (b) BESS comprising a separated/isolated PCE connected to a.c. system (d.c. connections may also be present).
- (c) BESS comprising a non-separated/non-isolated PCE connected to a.c. system (d.c. connections may also be present).

The PCE functions include the following:

- (i) d.c. to d.c. converter or a.c. to d.c. battery charger.
- (ii) Stand-alone inverter or multiple mode inverter or other grid connect inverter which allows interconnection with battery systems.

NOTE Some battery systems have additional inbuilt PCEs (e.g. d.c. to d.c. converters) and are considered part of the auxiliary equipment and form part of the battery system.

### 2.3.2 System architectures

A system installation may comprise any one of the following:

- (a) A BESS having one battery system connected to one or more PCE(s).
- (b) A BESS having parallel battery systems connected to one or more PCE(s).
- (c) Multiple BESSs, each individual BESS comprising one or more battery systems connected to one or more PCE(s).

When an installation comprises multiple BESSs (see [Figures 2.11](#) and [2.12](#)), for which the combined energy storage rating of the installation is > 200 kWh, this Standard applies to each individual BESS forming part of that installation and for which the energy storage rating is ≤ 200 kWh.

### 2.3.3 Electrical diagrams

[Figures 2.8](#) to [2.12](#) illustrate some typical electrical configurations of BESS installations: ranging from a BESS comprising a single battery string and single PCE through to multiple BESSs connected in parallel to the battery port of the PCEs.

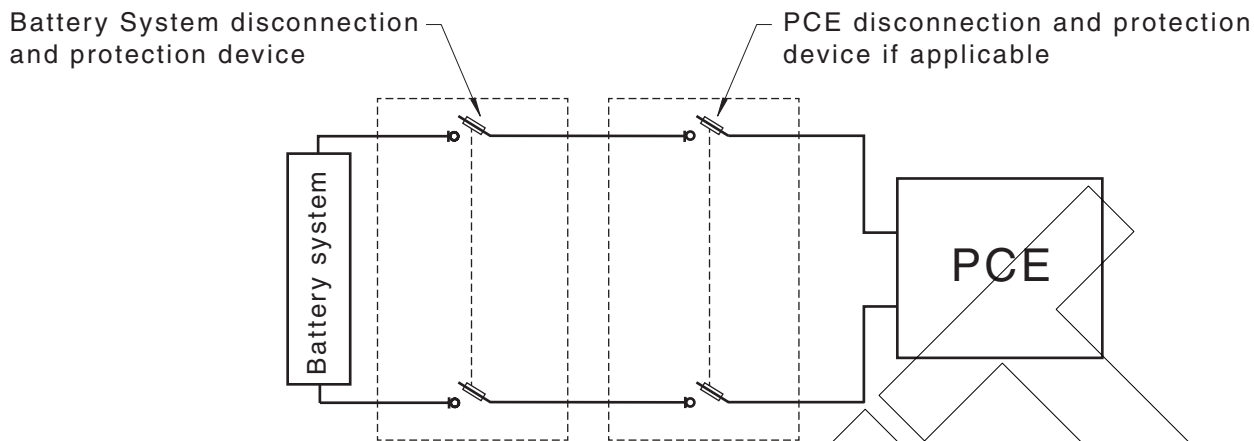

NOTE Switched fuses are shown as the protection and disconnection devices, these could be suitably rated d.c. circuit breakers.

**Figure 2.8 — Typical BESS installation diagram: BESS with single battery system connected to single PCE**

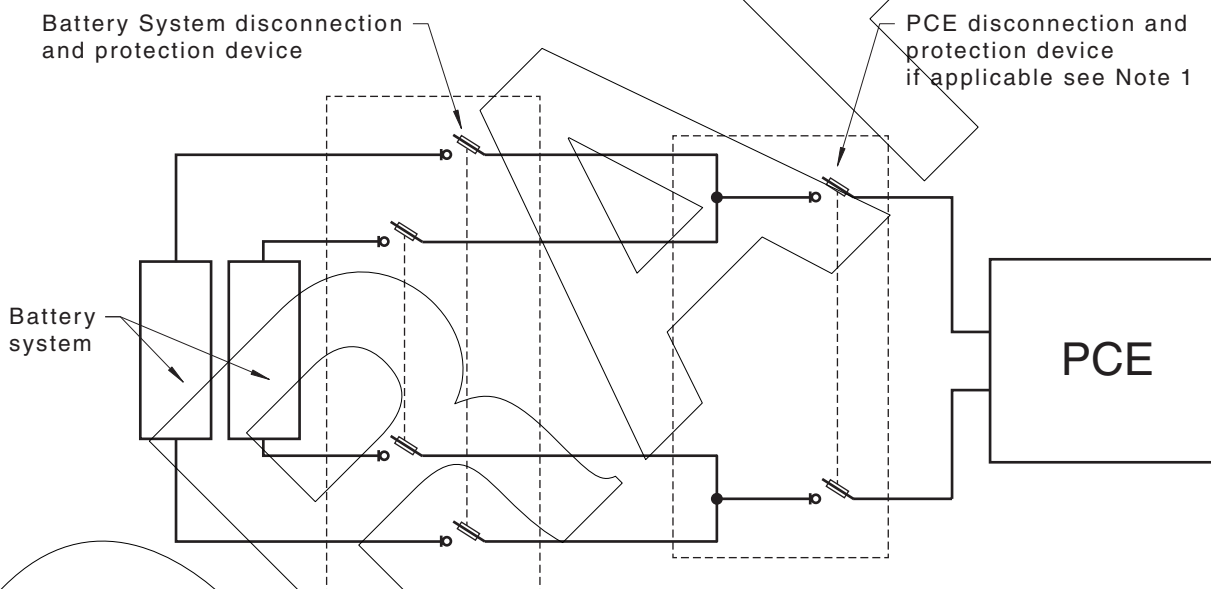

NOTE 1 PCE disconnection device required if battery system is not adjacent to the PCE and protection device installed if required.

NOTE 2 Switched fuses are shown as the protection and disconnection devices, these could be suitably rated d.c. circuit breakers.

**Figure 2.9 — Typical BESS installation diagram: BESS with parallel battery systems connected to single PCE**

PUBLIC COMMENTING DRAFT

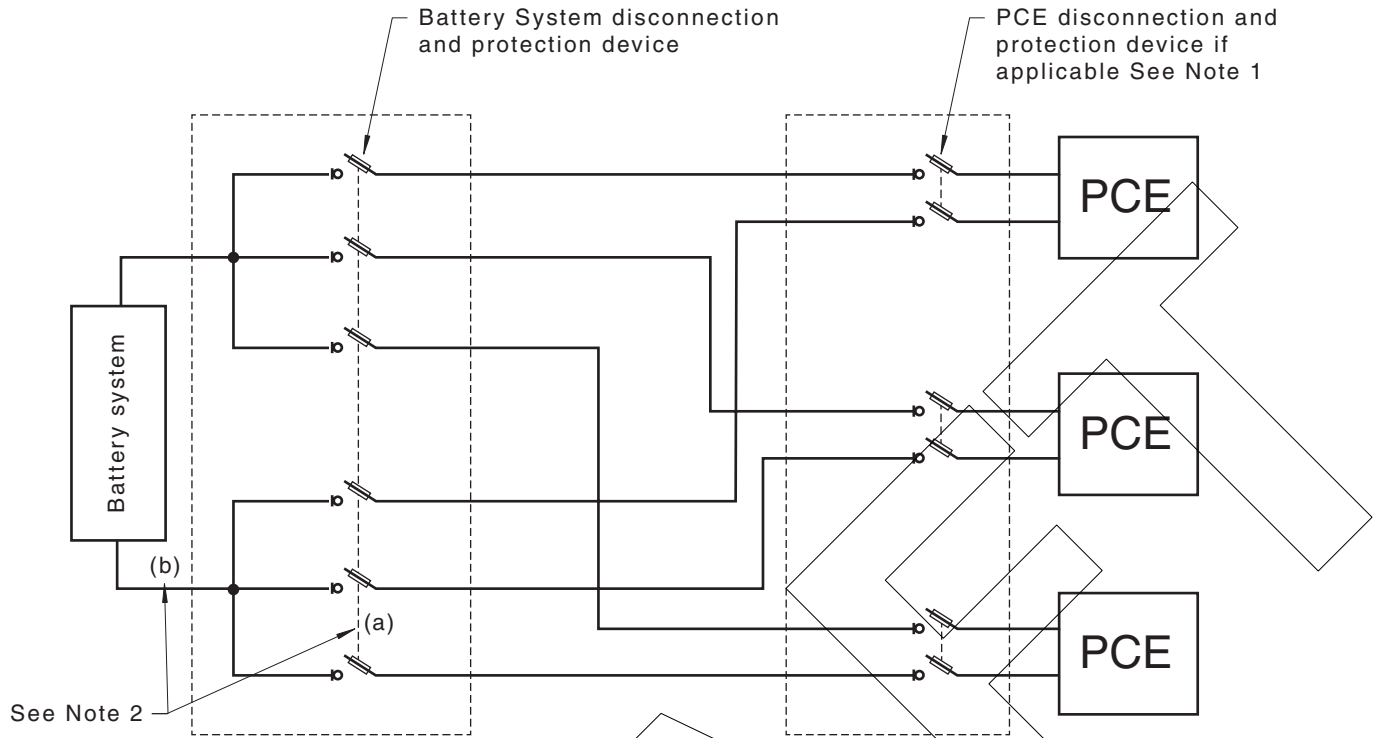

NOTE 1 PCE disconnection device required if battery system is not adjacent to the PCE or if the PCEs are performing different functions, and protection device installed if required.

NOTE 2 Insert either common ganged disconnection device in location (a) or insert main battery disconnection device in location (b).

NOTE 3 Switched fuses are shown as the protection and disconnection devices; these could be suitably rated d.c. circuit breakers.

**Figure 2.10 — Typical BESS installation diagram: BESS with single battery system connected to multiple PCEs**

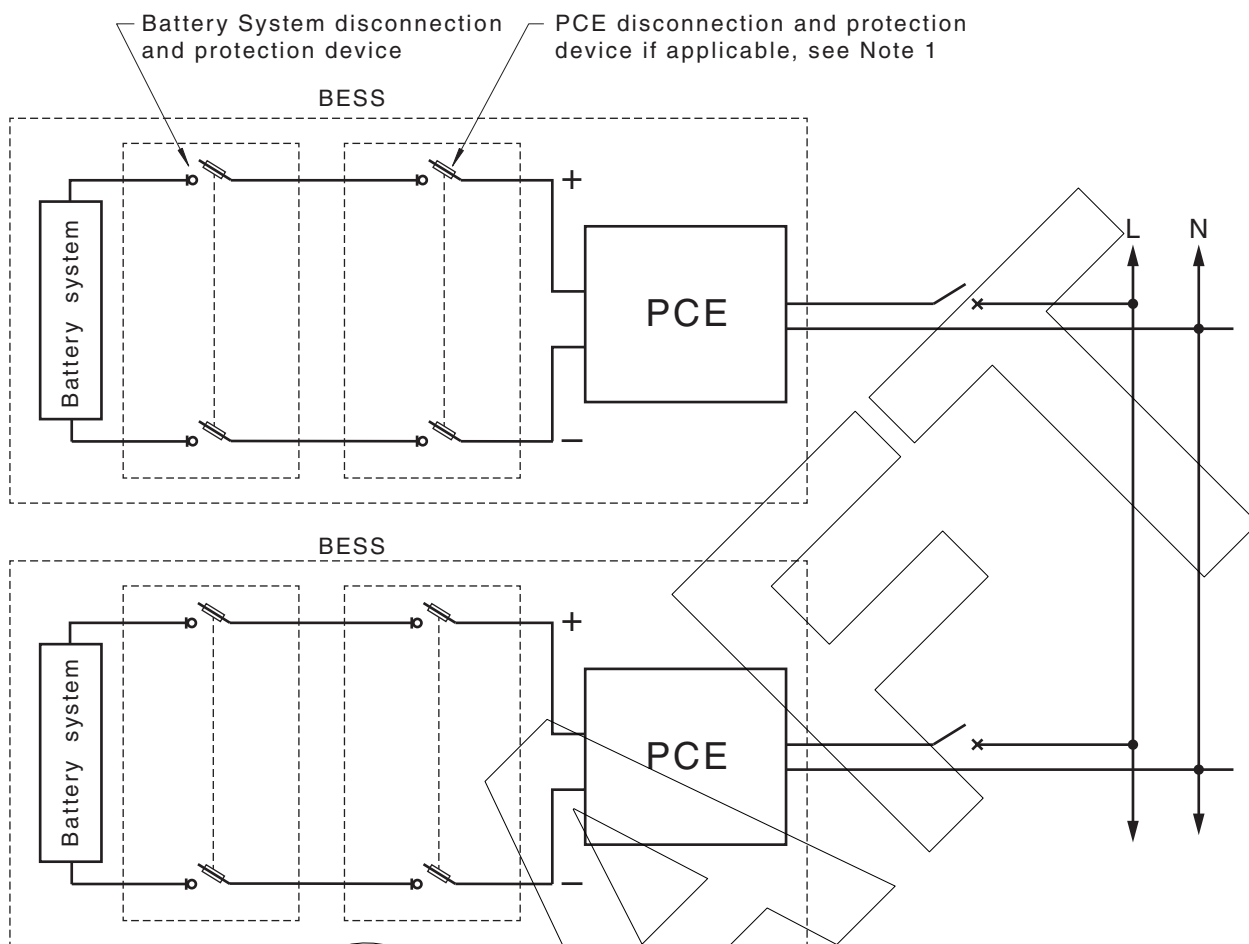

NOTE 1 PCE disconnection device required if battery system is not adjacent to the PCE and protection device installed if required.

NOTE 2 Switched fuses are shown as the d.c. protection and disconnection devices, these could be suitably rated d.c circuit breakers.

**Figure 2.11 — Typical BESS installation diagram: multiple BESSs each with single battery system connected to single PCEs**

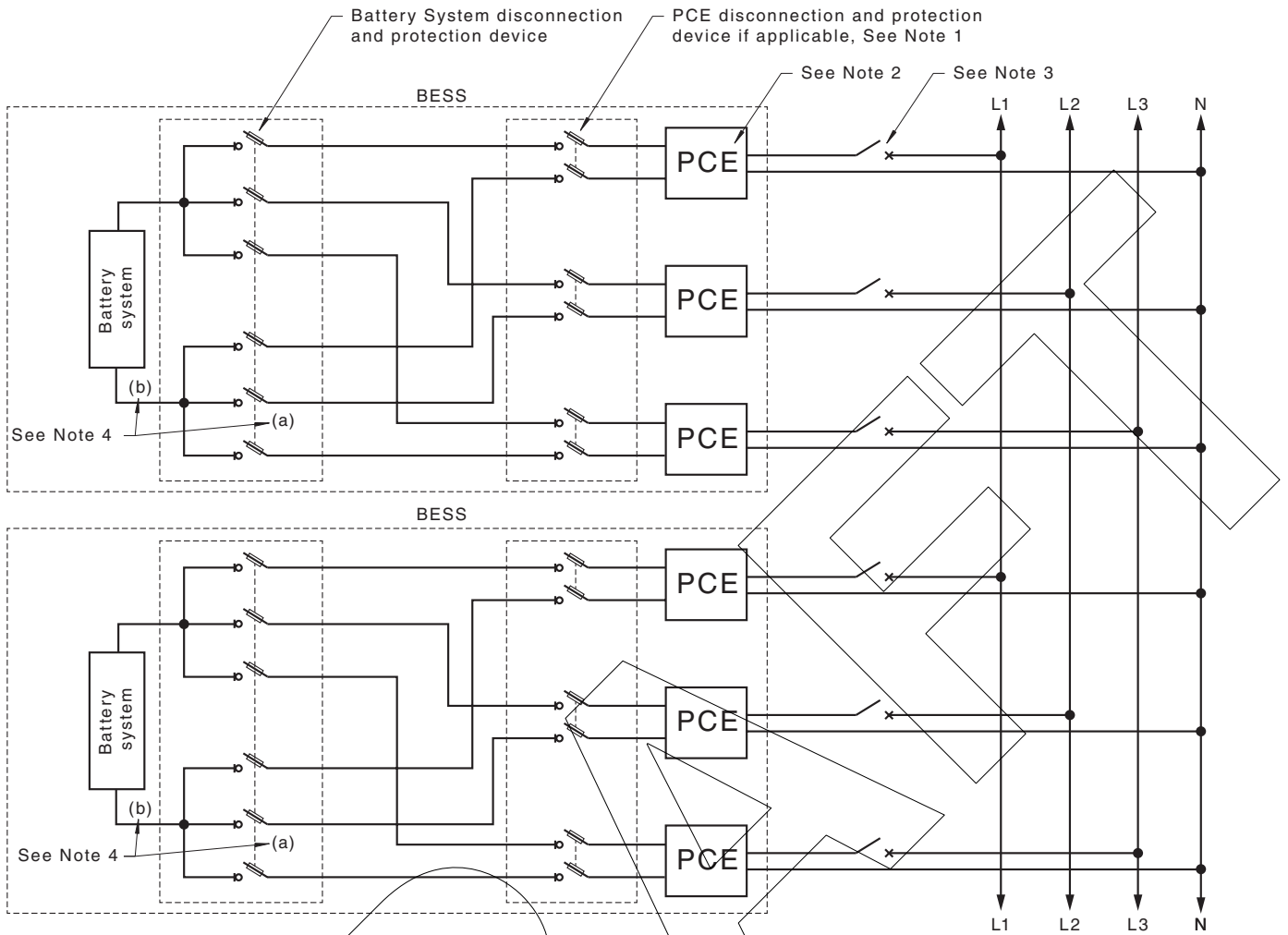

NOTE 1 PCE disconnection device required if battery system is not adjacent to the PCE or if the PCEs are performing different functions and protection device installed if required.

NOTE 2 Typical variation shown: two groups of three single phase PCE. Other variations are possible.

NOTE 3 PCE isolation requirements are specified in AS/NZS 4777 series or AS/NZS 4509 or AS/NZS 3000 as applicable.

NOTE 4 Insert either common ganged disconnection device (a) or insert main battery disconnection device (b).

NOTE 5 Switched fuses are shown as the d.c. protection and disconnection devices, these could be suitably rated d.c circuit breakers.

**Figure 2.12 — Typical BESS installation diagram — Multiple BESSs each with single battery system connected to multiple PCEs**

## Section 3 Battery energy storage system hazards

### 3.1 General

BESSs and battery systems use chemicals to store significant energy within a relatively compact space. The management of hazards associated with battery systems and BESSs shall be considered in the design and installation of these systems. Any battery energy storage system can present or create many or all of the hazards noted within this Section. This [Section 3](#) details the types of hazards a battery system can present. [Sections 4, 5](#) and [6](#) deal with design and installation practices to “manage risks” by eliminating health and safety risks so far as is reasonably practicable in dealing with these hazards.

The safety data sheets (SDSs) and the manufacturer’s installation instructions shall be provided for all battery energy storage systems or their equipment subsets to set out specific information in relation to the hazards covered in this [Section 3](#).

### 3.2 Hazards associated with a BESS

#### 3.2.1 General

This [Clause 3.2](#) outlines the following seven main hazard types associated with battery energy storage systems and any part thereof:

- (a) Electrical hazard.
- (b) Energy hazard.
- (c) Fire hazard.
- (d) Explosive gas hazard.
- (e) Chemical hazard.
- (f) Mechanical hazard.
- (g) Toxic fume hazard.

Installation requirements that are necessary to eliminate health and safety risks so far as is reasonably practicable, and if that is not possible, minimizing the risks so far as is reasonably practicable from these hazards are included in [Sections 4, 5](#) and [6](#).

#### 3.2.2 Hazard classification by battery type

A battery energy storage system may comprise one or more battery types. Each of these battery types presents type-specific operating characteristics and hazards. The safe handling, installation, operation and servicing of different battery types rely on identifying which hazards are peculiar to each of the battery types and taking this into account in their installation.

For the purpose of this standard [Table 3.1](#) sets out classifications of the specified battery type for a range of identified hazards. [Sections 4, 5](#) and [6](#) of this standard then provide installation requirements for the minimizing of the risks so far as is reasonably practicable of the risk of each hazard classification shown. If the battery type intended for installation or servicing is not included as part of [Table 3.1](#), a risk assessment shall be undertaken to categorize the battery type with respect to the hazard classifications stated in [Table 3.1](#) or any other hazard relevant to that battery type.

NOTE 1 Notes to [Table 3.1](#) provide further detail on classifications in for particular situations.

A copy of the risk assessment shall be included with the documentation provided to the client.

NOTE 2 An example in the application of the risk management process is shown in [Appendix G](#).



**Table 3.1 — Hazard classifications by battery type**

Battery chemistry	Electrical hazard	Energy hazard	Fire hazard: level 1 or 2	Explosive gas hazard	Chemical hazard	Mechanical hazard	Toxic fume hazard
Lead acid	✓	✓	2 (Note 1)	✓	✓	✓	✓
Nickel alkaline	✓	✓	2 (Note 1)	✓	✓	✓	✓
Lithium ion	✓	✓	1 (Note 2)	✓ (Note 3)	N/A	✓	✓
Flow	✓	✓	N/A	✓ (Note 4)	✓	✓	✓ (Note 4)
Hybrid ion	✓	✓	N/A	N/A	N/A	✓	✓

NOTE 1 Lead acid and nickel alkaline based batteries with cases that conform to V0 specification in accordance with relevant product standards are N/A for this hazard classification.

NOTE 2 Lithium ion pre-assembled battery system equipment or pre-assembled integrated BESS equipment conforming to the *Best Practice Guide: battery storage equipment — Electrical Safety Requirements* are N/A for this hazard classification.

NOTE 3 Lithium chemistries that release hydrogen under fault conditions should be considered an explosive gas hazard, e.g. lithium manganese.

NOTE 4 Flow batteries having an acidic water-based solution have a significant risk of producing explosive gases and toxic fumes.

NOTE 5 Where the table or the notes state N/A that is only related to the classification level for [Table 3.1](#), so as to assist in clarifying action required to be taken as outlined in [Sections 4, 5 and 6](#). This is based on accepted knowledge, additional actions or other measures in place to minimize the risks so far as is reasonably practicable for the identified hazard, and it is not intended to necessarily indicate any particular hazard does not exist for the particular battery type.

### 3.2.3 Electrical hazard

#### 3.2.3.1 General

The electrical risks associated with a battery system are strongly dependent on the voltage of the battery bank, the characteristics of any other equipment that is connected to the battery system (e.g. PCE and/or energy source), the earthing, the protection systems, all interconnections, cable types, method of protection plus terminations and siting of protection devices.

#### 3.2.3.2 Decisive voltage classification (DVC)

The decisive voltage classification (DVC), as defined in IEC 62109-1, shall be applied in this Standard. [Table 3.2](#) provides a summary of DVC levels.

The DVC system refers to the voltage level and also the degree of separation of the relevant battery port from the grid or from any other energy source (e.g. in the case of a charge controller, as installed with a PV array). This type of classification simplifies the decisions associated with protection and enclosure requirements for a battery system.

The classification of circuits of power conversion equipment (PCE) (including inverters and charge controllers) shall be made according to their decisive voltage classification (DVC).

All inverter and PCE ports shall be classified and marked according to their DVC classification. Refer to AS/NZS 4777.2:2015, Clause 9.3.3(h) and IEC 62109-1.

NOTE See [Appendix A](#) for additional information.

Table 3.2 — Summary of decisive voltage classification voltage ranges

Decisive voltage classification (DVC)	Limits of working voltage		
	a.c. voltage r.m.s.	a.c. voltage peak	d.c. voltage mean
A	≤ 25	≤ 35.4	≤ 60
B	≤ 50	≤ 71	≤ 120
C	> 50	> 71	> 120

NOTE 1 Under fault conditions, DVC-A circuits are permitted to have voltages up to the DVC-B limits for a maximum of 0.2 s.

NOTE 2 If a battery system is either DVC-B or DVC-C it will be treated as an LV installation as defined in AS/NZS 3000.

NOTE 3 The ripple free voltage value is the d.c. working voltage mean value, where the peak value caused by a ripple voltage of r.m.s. value not greater than 10 % of d.c. voltage.

### 3.2.3.3 Battery system prospective fault current/ short-circuit current

The prospective fault current (or prospective short circuit current) at the battery terminals of the battery system shall be based on the fault current able to be supplied by the battery cell, module or bank prior to the interaction of any battery management system.

To determine the sizing of the battery prospective fault current protection the battery system manufacturer should be consulted to identify the cell prospective fault current capability. If information regarding the cell prospective fault current is not available from the manufacturer, the battery system should not be installed.

NOTE The internal resistance of a cell (lead acid type or similar) may be determined by the method shown in AS 2676.1 and AS 2676.2.

The cell short-circuit current may be calculated according to the following equation:

$$I_{sc} = \frac{V_{oc}}{R_i} \quad 3.2.3$$

where

$I_{sc}$  = cell short-circuit current, in amperes

$V_{oc}$  = cell open-circuit voltage, in volts

$R_i$  = cell internal resistance at full charge, in ohms

### 3.2.4 Energy hazard

#### 3.2.4.1 General

Arc flash occurs when electrical current passes through the air between electrified conductors when there is insufficient isolation or insulation to withstand the applied voltage.

Arc flash incident energy is dependent on the voltage, current and the length of time that the arc occurs. The energy dissipates out from the arc flash incident so it is at its greatest at the incident and diminishes further away from the incident.

Arc flash incident energy determines the location requirements of the battery system, and the personal protective equipment (PPE) required for protection within the arc flash boundary while installing and maintaining the battery system.

BESS and battery systems exposed to mechanical damage, inappropriate use and electrical faults may result in dangerous energy discharge and arc flash occurring.

Arc flash incident energy and arc flash boundary has been calculated for a number of example systems, see [Appendix F](#).

### 3.2.4.2 Determining arc flash incident energy

#### 3.2.4.2.1 General

The arc flash incident energy for battery systems having system voltages equal or less than 1000 V d.c. is calculated using the following equation:

$$IE_m = 0.01 \times V_{\text{sys}} \times I_{\text{arc}} \times (T_{\text{arc}}/D^2) \times MF \quad 3.2.4(1)$$

where

$IE_m$  = estimated d.c. arc flash incident energy at the maximum power point, in cal/cm<sup>2</sup>

$V_{\text{sys}}$  = system voltage, in volts

$I_{\text{arc}}$  = arcing current, in amperes

$T_{\text{arc}}$  = arcing time, in seconds

$D$  = working distance, in centimetres

$MF$  = multiplying factor

while

$$I_{\text{arc}} = 0.5 \times I_{\text{bf}} \quad 3.2.4(2)$$

where

$I_{\text{bf}}$  = battery prospective fault current, in amps (see [Clause 3.2.3.3](#))

NOTE See [Appendix F](#) for arc flash worked examples.

#### 3.2.4.2.2 Working distance

When calculating the arc flash energy, a maximum working distance of 45 cm shall be applied (see also [Clause 6.3.2.5](#)).

#### 3.2.4.2.3 Arcing time

The arcing time will relate to the part of the system that is having work undertaken.

For work being undertaken on the PCE side of the battery system's protection device, the operating time for the protection based on the prospective fault current shall be used as the arcing time.

If the operational time of the protective device is unknown, an arcing time of two seconds shall be applied.

For work being undertaken on the battery system side of the battery system's protective device, an arcing time of two seconds shall be applied.

### 3.2.4.3 Multiplying factor

The arc flash energy calculated according to [Equation 3.2.4\(1\)](#) is dissipated radially. A battery system (or systems) is located in an enclosure or in a room, where the area over which the energy to be dissipated is restricted by walls, enclosure roof or even the battery system. This physical limitation means that the amount of energy dissipated in the direction of a person working on the battery could be increased. The factor by which it is increased is known as the multiplying factor.

For battery system enclosures and BESS enclosures, a minimum multiplying factor of 3 shall be applied; while for battery system rooms, a minimum multiplying factor of 1.5 shall be applied, unless specific other information is provided by the manufacturer.

NOTE See [Appendix F](#) for example arc flash calculations.

### 3.2.4.4 Selecting personal protective equipment (PPE)

The required PPE shall be determined having calculated the arc flash energy and by applying [Table 3.3](#). This selected PPE shall be worn within the arc flash boundary.

Bracelets, rings, jewellery and exposed metal zips, watches and other conductive items shall not be worn while working on or near exposed energised parts or live conductive parts.

**Table 3.3 — Personal protective equipment for arc flash protection**

PPE level	cal/cm <sup>2</sup>	PPE description
1	0 and ≤ 4	Flame retardant long sleeve shirt and pants Safety glasses/goggles Hearing protection Heavy duty leather gloves
2	> 4 and ≤ 8	Arc-rated long sleeve shirt and pants Arc-rated face shield (wrap around to protect face, forehead, ears and neck) and arc-rated balaclava Hard hat Safety glasses/goggles (worn under hood or shield) Hearing protection (ear canal inserts) Arc-rated gloves (with voltage rating as needed) Protective rubber soled leather footwear
3	> 8 and ≤ 25	Arc-rated long sleeve shirt and pants and arc-rated flash suit (jacket, pants, hood) such that system arc rating meets minimum requirements of 25 cal/cm <sup>2</sup> Arc-rated jacket, parka rainwear or hard hat liner may also be required Hard hat Safety glasses/goggles (worn under hood or shield) Hearing protection (ear canal inserts) Arc-rated gloves (with voltage rating as needed) Protective rubber soled leather footwear

NOTE 1 PPE clothing is rated in calories (unit: cal). The unit joule is not used in this application. The conversion of calories to joules is temperature dependent, e.g. at 15 °C, the conversion factor is 1 cal = 4.18 J.

NOTE 2 PPE description requirements is the minimum requirements and other regulations may require additional PPE. Additional local occupational safety and health requirements may also be applicable. PPE protection may also be required for mechanical and chemical hazards.

**Table 3.3** (continued)

PPE level	cal/cm <sup>2</sup>	PPE description
4	> 25 and ≤ 40	Arc-rated long sleeve shirt and pants and arc-rated flash suit (jacket, pants, hood) such that system arc rating meets minimum requirements of 40 cal/cm <sup>2</sup> Arc-rated jacket, parka rainwear or hard hat liner may also be required Hard hat Safety glasses/goggles (worn under hood or shield) Hearing protection (ear canal inserts) Arc-rated gloves (with voltage rating as needed) Protective rubber soled leather footwear
5	> 40	Measures shall be taken in installation to avoid this level as PPE is very limited

NOTE 1 PPE clothing is rated in calories (unit: cal). The unit joule is not used in this application. The conversion of calories to joules is temperature dependent, e.g. at 15 °C, the conversion factor is 1 cal = 4.18 J.

NOTE 2 PPE description requirements is the minimum requirements and other regulations may require additional PPE. Additional local occupational safety and health requirements may also be applicable. PPE protection may also be required for mechanical and chemical hazards.

### 3.2.5 Fire hazard

#### 3.2.5.1 General

Based on the type of battery system used, the risk of fire may result from any of the following:

- Excessively high and low temperatures.
- Over and under voltage.
- Over charged or over discharged.
- Puncturing or failure of the battery case either under normal operating conditions or due to overload, component failure, insulation breakdown, loose connections or misuse.

Battery systems and BESSs shall be installed in such a manner that, in the event of fire originating within the battery system or battery energy storage system, the spread of fire will be kept to a minimum.

[Clauses 3.2.5.2](#) and [3.2.5.3](#) detail the fire risk directly related to the specific types of battery chemistry within a battery system.

#### 3.2.5.2 Batteries that emit flammable gases

The risk of a fire from lead acid or nickel alkaline battery systems or battery systems with similar chemistries may result from the combination of an ignition source and the local concentration of hydrogen gases that are emitted when the battery system is being overcharged and the flammable materials of the battery or battery system.

NOTE [Clause 3.2.6](#) refers to the explosive gas hazard of these types of batteries.

The fire hazard of these battery systems relates to the battery or battery system igniting and propagating the fire to other parts. See [Clause 6.3.5](#) regarding the ventilation requirements to reduce the concentration of the hydrogen to a safe level and regarding removing the risk of spark hazards where the explosive gases are present.

Lead acid batteries that have flame retardant cases to V0 specification as provided in IEC 60707, or IEC 60695-11-10, IEC 60695-11-20, or ISO 9772 and ISO 9773 are considered to minimize the risks so far as is reasonably practicable for the identified fire hazard and are N/A for this fire hazard classification (see [Table 3.1](#)).

### 3.2.5.3 Lithium ion batteries

Fire in a lithium ion battery may be caused by the following:

- (a) The thermal runaway of the batteries.
- (b) A short-circuit event of the internal electrodes, which leads to thermal runaway.
- (c) Overvoltage/overcharge, which builds internal pressure, eventually venting explosive gasses for some chemistries and housing types.

NOTE 1 Thermal runaway occurs when the lithium breaks down at the cathode and reacts with the electrolyte and causes an exothermic reaction, which results in oxygen being released and a fire. The temperature at which thermal runaway occurs varies according to the lithium ion chemistry. The breakdown in lithium at the cathode can result from overcharging leading to overvoltage or operating cell temperatures in excess of the maximum temperature allowed for the battery or from charging currents exceeding the maximum charge current.

NOTE 2 Short-circuiting of lithium ion batteries occurs either through dendrite growth on the anode or copper from the anode dissolving in the electrolyte which can be caused by over-discharge of the battery.

NOTE 3 Lithium ion chemistries will present different risk profiles according to the chemistry type, physical construction and combustion by-products.

NOTE 4 When lithium batteries burn they produce HCl, HCN, HF and CO. Production of these gasses can continue even after the fire has been extinguished.

NOTE 5 Many lithium batteries have the potential, when on fire, to sustain the fire. Many lithium batteries are categorized as fire hazard level 1 that is self-sustaining, as they are likely to continue to burn for a significant period. As this battery burns it generates more fuel to burn. This can occur regardless of whether it is the source of the fire, or is independent of the fire source.

NOTE 6 Lithium ion pre-assembled battery system equipment or pre-assembled integrated BESS equipment conforming to the *Best Practice Guide: battery storage equipment – Electrical Safety Requirements* are considered to minimize the risks so far as is reasonably practicable for the identified hazard and are N/A for this fire hazard classification (see [Table 3.1](#)).

### 3.2.6 Explosive gas hazard

This Clause refers to those batteries that generate explosive gasses such as hydrogen when being charged, and hence are deemed an explosive gas hazard. Battery systems that exhibit this characteristic consist of acid and alkaline-based batteries. The most common acid battery is the lead acid battery, while nickel cadmium and nickel metal hydride batteries are included in the alkaline category. Lead acid and alkaline batteries are available as vented or sealed valve-regulated batteries.

Batteries may be irreversibly damaged when subjected to sustained electrical misuse. The manufacturer's charging regimes shall be observed. Generally, sealed valve-regulated lead acid batteries have much tighter charging tolerances than vented cells.

NOTE Any lead acid battery can produce gas under normal operation and/or because of electrical abuse. One example is when the charge received is incorrectly adjusted, for example due to incorrect charge settings or a faulty charger or failure of some protection devices (e.g. where there are multiple strings). If the hydrogen is between 4 % and 76 % as a proportion of the air mixture, the hydrogen by volume is combustible and burning is enhanced by oxygen enrichment. In this environment, any electrical sparks, e.g. from short circuits, faults, fans, motors, switches and lights, can cause explosions including internally to the devices installed and enclosures installed.

### 3.2.7 Chemical hazard

All battery systems store chemical energy, and most contain fluid or gel electrolyte materials. In the event of an accident that damages the battery casing, chemical leakage can create a hazard.

Safety data sheets provide information for all chemicals that are part of the battery system. The information contained within the safety data sheet needs to be understood by those persons



working with the battery systems. Information in the safety data sheets includes important handling information, what to do in the event of an emergency or spill, first aid information and the hazards of the chemical including health, physical and environmental hazards. The different chemicals used can result in burns to skin, environmental hazards if leaked into soils or waterways, accelerated failure of supporting infrastructure, e.g. accelerated corrosion.

### 3.2.8 Mechanical hazard

Mechanical hazards related to battery systems include the following:

- (a) Weight.
- (b) Sharp edges and corners.
- (c) Moving parts (e.g. pumps in flow batteries).
- (d) Falling over/tipping/seismic (e.g. BESS products and certain battery formats which are tall and narrow).
- (e) Lack of lifting or securing accessories on batteries or systems.

When installing a battery system, mechanical hazards applicable to the type, quantity, profile and size of the battery system to be installed shall be taken into account.

### 3.2.9 Toxic fume hazard

Batteries that generate toxic fumes under normal operation or fault conditions are a toxic fume hazard. When installing a battery system, the toxic fume hazards applicable to the type, quantity, profile and size of the battery system to be installed should be taken into account.

The battery system manufacturer or the SDS should be consulted when assessing the risk level of toxic fume hazard for the specific battery chemistry.

## Section 4 Pre-assembled integrated BESSs — Installation, commissioning and documentation

### 4.1 General requirements

This Section applies for the installation of lithium ion pre-assembled integrated battery energy storage system (BESS) equipment conforming to the *Best Practice Guide: battery storage equipment — Electrical Safety Requirements* and in this Section “pre-assembled integrated BESS” means that equipment. Pre-assembled integrated BESS equipment that do not conform with the *Best Practice Guide: battery storage equipment — Electrical Safety Requirements* shall be installed as BESS as per [Section 6](#).

See [Clause 4.4.2.3](#) for requirements on how alterations to the pre-assembled integrated BESS affect the scope of this Section.

### 4.2 Installation requirements

#### 4.2.1 General

Pre-assembled integrated BESSs shall be installed by competent persons.

Equipment that is mechanically damaged or damaged in any other way shall not be installed.

All the hazards associated with the relevant battery type and all associated components shall be identified. A risk assessment shall be performed prior to planning an installation of a pre-assembled integrated BESS.

NOTE See [Appendix G](#) for additional information on risk assessment.

Each pre-assembled integrated BESS should be installed with reference to the relevant safety data sheets (SDS), manufacturer system hazard information and the manufacturer’s installation, commissioning and maintenance instructions.

The a.c. electrical interconnection of the pre-assembled integrated BESS to the switchboard or distribution board shall be in accordance with AS/NZS 3000. Furthermore, if the pre-assembled integrated BESS is able to operate in parallel to the grid or inject electric power into an electrical installation connected to the grid at low voltage, the installation shall meet all the requirements of AS/NZS 4777.1. If the pre-assembled integrated BESS is intended to operate as a stand-alone power system, the BESS installation shall meet all the requirements of AS/NZS 4509.1.

Additional enclosure or housing is only required if the pre-assembled integrated BESS installation requires a greater level of protection — based on environment, location, venting or other site issues.

#### 4.2.2 Location

##### 4.2.2.1 General

Pre-assembled integrated BESSs shall be protected from mechanical damage, environmental and other external influences. Where the location chosen may expose the pre-assembled integrated BESS to influences that might be reasonably expected then they should be considered as part of the installation conditions, e.g. damaged caused by a vehicle if a system is being installed in a carport or garage.

Pre-assembled integrated BESSs shall be installed in accordance with the manufacturer’s instructions. The location of the pre-assembled integrated BESS shall provide readily available access to —

- (a) connections and any serviceable equipment; and
- (b) doors and panels that are required to be accessed for installation and maintenance purposes.



The installation of pre-assembled integrated BESS shall conform to the requirements for damp situations defined by Section 6 of AS/NZS 3000.

Pre-assembled integrated BESS locations shall be determined by outcome of the risk assessment (see [Clause 4.2.1](#)).

Pre-assembled integrated BESS shall not be installed —

- (i) in ceiling spaces;
- (ii) wall cavities;
- (iii) on roofs not specifically deemed suitable;
- (iv) under stairways; or
- (v) under access walkways.

In areas of domestic or residential electrical installation, pre-assembled integrated BESS shall not be located in habitable rooms;

Suitable areas may include garages, storage rooms, dedicated battery system room and verandas.

Installation of pre-assembled integrated BESS should also take into account requirements for spacing between —

- (A) multiple BESS; and
- (B) the BESS and other associated equipment.

#### 4.2.2.2 Restricted locations

A pre-assembled integrated BESS shall not be installed —

- (a) in restricted locations, as defined for switchboards in AS/NZS 3000;
- (b) within 600 mm of any exit;
- (c) within 600 mm any hot water unit, air conditioning unit or any other appliance not associated with the Pre-assembled integrated BESS.
- (d) or within 1200 mm below any of the items included in (b) and (c).

A pre-assembled integrated BESS shall not be installed below, or within 600 mm of the vertical side of, any window and building ventilation opening.

[Figure 4.1](#) shows the restricted zones for equipment of this Clause.

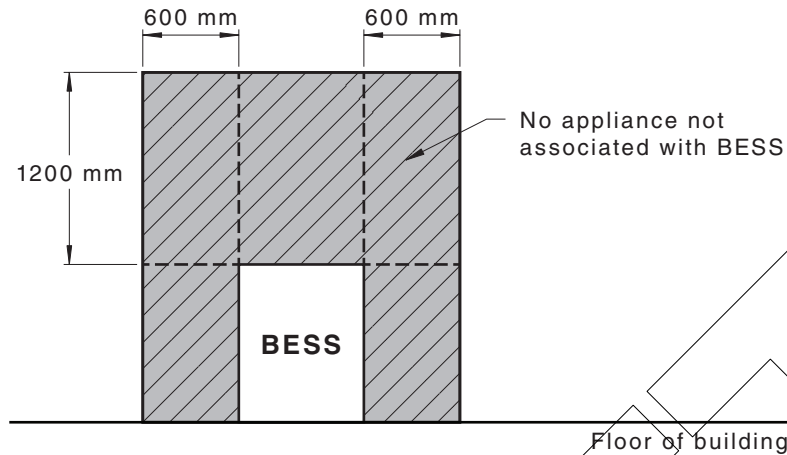

**Figure 4.1 — Restricted zones for equipment not associated with the BESS**

A pre-assembled integrated BESS installed in any corridor, hallway, lobby or the like leading to a fire exit shall ensure sufficient clearance from the BESS for safe egress, and be no less than 1 m.

A pre-assembled integrated BESS is considered a source of ignition and therefore shall not be installed within hazardous area for gas cylinders containing heavier than air gasses and gas relief vent terminal as defined in Section 4 of AS/NZS 3000.

#### 4.2.3 Environmental requirements

##### 4.2.3.1 General

Pre-assembled integrated BESSs shall not be installed in locations where they will be exposed to temperatures lower than the minimum or greater than the maximum temperatures, as specified by the pre-assembled integrated BESS manufacturer.

The pre-assembled integrated BESS shall be selected and installed to provide protection against damage that might reasonably be expected from the presence of water, high humidity, dust, vermin or solar radiation (direct sunlight).

Pre-assembled integrated BESS should be installed in locations that avoid localized or general heat sources (such as sunlight, generators, steam pipes, hot water systems, air conditioners, space heaters and against uninsulated walls heated from direct sunlight). The flow of heated air from any appliance should be directed away from, and not impact on, the pre-assembled integrated BESS.

A pre-assembled integrated BESS should not be located near combustible materials.

##### 4.2.3.2 IP rating

The pre-assembled integrated BESS installation shall have protection against ingress of solid foreign objects and against ingress of water. The pre-assembled integrated BESS shall have an IP code rating as specified in IEC 60529 for the environment in which it is to be installed.

Pre-assembled integrated BESS shall have a minimum protection of IP2X.

Pre-assembled integrated BESS installed outdoors shall have IP rating suitable for the location and be at least of IP23.

NOTE 1 The installation of pre-assembled integrated BESS enclosures indoors may have other restrictions based on their identified hazards.

NOTE 2 IP23 is the minimum and AS/NZS 3000 may require higher rating depending on location. For example, due to the environment not being fully sealed from the effects of weather, or having water or other liquid storage system in the same location, or being in the vicinity of areas where use of a hose or washing activity of any kind may occur, or having water taps or the like.

#### 4.2.4 Protective against spread of fire

##### 4.2.4.1 General

Selection and installation of pre-assembled integrated BESS equipment shall not contribute to, or propagate a fire in accordance with AS/NZS 3000:2018 Clause 1.5.12.

NOTE This requirement is not specifically for the fire hazard of [Table 3.1](#) that is covered in [Clause 4.3.3](#).

##### 4.2.4.2 Barrier to habitable rooms

For the purposes of this Clause, a surface or barrier material is considered suitably non-combustible if the material is deemed to be not combustible when tested in accordance with AS 1530.1. Materials exempt from the need to be tested to AS 1530.1 and considered to be suitably non-combustible are —

- (a) brick or masonry block;
- (b) concrete;
- (c) steel of at least 0.2 mm thickness; and
- (d) ceramic or terracotta tiles.

The material shall have no vents or perforations within the zone required to be covered by the barrier. Any penetration of the barrier that has an internal free space greater than 5 mm diameter shall be sealed with a fire retardant sealant.

To protect against the spread of fire to habitable rooms, where the pre-assembled integrated BESS is mounted on or placed against a surface of a wall or structure that has a habitable room on the other side, the wall or structure shall be a suitably non-combustible barrier. If the mounting surface itself is not made of a suitably non-combustible material, a non-combustible barrier shall be placed between the pre-assembled integrated BESS and the surface of a wall or structure.

Where the BESS is located on, or mounted on the floor within 300 mm of the wall or structure separating it from the habitable room, the barrier shall extend —

- (i) 600 mm beyond the vertical sides of the BESS;
- (ii) 1200 mm above the BESS; and
- (iii) to the extent of the bottom of the BESS.

NOTE See [Figure 4.2](#) and [Appendix E](#) for typical layout examples.

Where the top of the pre-assembled integrated BESS is within 1200 mm of the ceiling or structure above the BESS, the ceiling or structure surface shall be suitably non-combustible for an area of 600 mm past the extremities of the BESS.

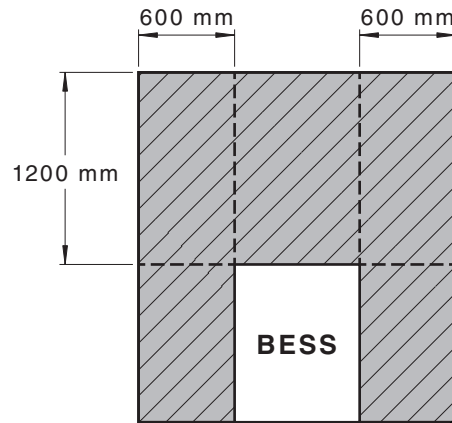

**Figure 4.2 — Barrier zones for pre-assembled integrated BESS installed on or near a habitable room facing wall**

**DRAFTING NOTE for public comment**

The background to this Clause 4.2.4 and the additional requirement of ensuring the BESS equipment is mounted against a surface that will reduce any fire spread is:

- the technology for battery storage equipment for mass market situations is still emerging and is relatively new. Experience of issues of the equipment and installation processes that ensures any fire risk is fully minimised, is still being developed and enhanced
- BESS equipment conforming to the Best Practice Guide have assessment for resistance to fire propagation, and therefore there is a level of confidence the equipment has addressed known and identified fire risks related to the equipment — this is reflected in this BESS equipment not classified as “fire hazard” in Table 3.1
- Nevertheless, as with all electrical equipment there remains a small residual fire risk and so it is prudent to apply installation requirements to address that residual risk.

This clause has a simple proposal to reduce any residual fire risk by having the BESS equipment located such that, in the rare event a fire might occur, the equipment will either be located against a wall that does not have a habitable room on the other side or, if a habitable room is on the other side of the wall, there is material to prevent fire burning through into the habitable room.

This clause is a simple easy-to-achieve location or surface material requirement. It is not intended to require a special room to be built, or for an onerous requirement of fireproofing the BESS equipment in an additional enclosure, or of placing the BESS equipment in a separate fireproof cabinet or box.

#### **4.2.5 Pre-assembled integrated BESS room requirements**

Where pre-assembled integrated BESS are installed within a room, the BESS shall be located so that access to a BESS is not obstructed by the structure of the building, fixtures and fittings within the room.

The room should be clean, dry and ventilated and provide and maintain protection against detrimental environmental conditions and other external factors. In addition the room should be selected to minimize likelihood of a build up of other materials around or on the BESS, or an infestation of insect or vermin, or similar issues occurring that may cause a hazard.

The size of the room shall allow for sufficient clearance around the pre-assembled integrated BESS to provide safe handling and access for installation and maintenance.

The room’s entry doors and panels shall open in the direction of egress and allow unobstructed access to the pre-assembled integrated BESS for installation and maintenance purposes.

The pre-assembled integrated BESS minimum unimpeded access on the working side of a system shall be no less than 600 mm or the clearance specified by the manufacturer whichever is greater. Where access panels allow access to 230 V a.c. connections a minimum clearance of 900 mm is required.

Pre-assembled integrated BESS shall be mounted with the highest point no greater than 2.2 m above the floor or platform level.

#### **4.2.6 Seismic (earthquake) forces**

Depending on location/application, the pre-assembled integrated BESS may need to be installed to withstand seismic (earthquake) forces.

For Australia, where the pre-assembled integrated BESS is installed in, or on, a building that is required to be designed for earthquake action, the earthquake action requirements for the pre-assembled integrated BESS shall be in accordance with AS 1170.4.

For New Zealand, where a higher level of seismic restraint is required, the pre-assembled integrated BESS seismic (earthquake) restraint shall be in accordance with NZS 4219.

The requirements for seismic restraint also mean that tall pre-assembled integrated BESS should be installed as close as possible to the floor.

For pre-assembled integrated BESS installations the designer/installer should seek advice from a structural engineer or similar.

### **4.3 Installation hazards**

#### **4.3.1 Electrical hazards**

##### **4.3.1.1 Isolation within the pre-assembled integrated BESS**

Some pre-assembled integrated BESS may still provide an isolation point between the battery system and the PCE that is required to be operated as part of the shut down procedure. In this instance, this isolation point shall be readily available.

##### **4.3.1.2 Additional connections to the pre-assembled integrated BESS**

Some systems have the ability to have additional generation ports and other devices (for example, PV arrays, generators, etc.) connected. Installation of additional energy sources shall be installed in accordance with Section 7 of AS/NZS 3000. Where the energy source is a PV array the installation shall meet the requirements of AS/NZS 5033.

##### **4.3.1.3 Grid port connections for the pre-assembled integrated BESS**

All grid connections for the pre-assembled BESS shall meet the requirements of AS/NZS 4777.1.

##### **4.3.1.4 Earthing of the pre-assembled integrated BESS**

###### **4.3.1.4.1 General**

Earthing of the pre-assembled BESS shall follow the manufacturer's earthing requirements and the AS/NZS 3000 earthing requirements.

###### **4.3.1.4.2 Earth fault protection — Monitoring alarm**

Earth fault protection of the pre-assembled BESS shall follow manufacturer's requirements for earth fault protection including any additional monitoring or alarm connections or devices.

### 4.3.2 Energy hazard — Arc flash

There is no possibility to completely avoid arc flash hazards when working near live parts. When working with pre-assembled integrated BESS, some parts of the pre-assembled integrated BESS will remain energized. To limit exposure levels to arc flash hazard all maintenance and installation activities shall be according to manufacturer's instructions for the pre-assembled integrated BESS.

### 4.3.3 Fire hazard

#### 4.3.3.1 General

Where a pre-assembled integrated BESS is installed in a building with a fire indication panel, a detector linked to that fire indication panel should be installed. For all other buildings a smoke alarm should be installed within the same room.

NOTE The pre-assembled integrated BESS location may have additional requirements in relation to fire separation between the BESS and the building to which it is attached and any adjacent building or allotment boundary in the relevant local, state or territory or national requirements, according to the building classification code.

#### 4.3.3.2 Battery alarm system

If an alarm system is provided as part of the pre-assembled integrated BESS, where it is an audible or visual signal the alarm shall be placed in an area where an authorized person will be aware of the signal. Where another form of alarm communication system is used to inform to the authorized person it shall be enabled and confirmed as part of commissioning. Suitable communication systems include email, SMS or similar messaging systems.

A set of operational instructions shall be provided to the system owner (or nominated representative) that includes the actions to be taken when the alarm is activated and to maintain any communication systems used.

### 4.3.4 Explosive gas hazard

For pre-assembled integrated BESS, the manufacturer's instructions on ventilation requirements shall be followed.

NOTE It is important that the installer follows the manufacturer's instructions as there are lithium ion systems that have specific ventilation requirements.

### 4.3.5 Chemical hazard

Pre-assembled integrated BESS that are categorized as chemical hazards in [Table 3.1](#) shall be installed in accordance with the following risk reduction requirements.

Any venting requirements of the pre-assembled integrated BESS manufacturer shall be implemented. Any containment requirements of the pre-assembled integrated BESS manufacturer shall be implemented.

### 4.3.6 Mechanical hazard

In addition to the requirements specified in [Clause 4.2.6](#), the installation of the pre-assembled integrated BESS shall be in accordance with the following:

- (a) For ground mounted BESS, the ground structure and type shall have structural strength to support the BESS weight.
- (b) For wall-mounted BESS, the structural integrity of the wall shall be able to withstand the weight of the BESS.



NOTE [Table 3.1](#) shows those battery types categorized as mechanical hazards.

#### 4.3.7 Toxic fume hazard

Where the pre-assembled integrated BESS is categorized as toxic fume hazards in [Table 3.1](#), the installation shall be in accordance with the instructions of the manufacturer.

Instructions provided by the manufacturer shall be included in the documentation provided to the system owner (or nominated representative).

Where vents are required, venting shall ensure toxic fumes are vented outside of building to minimize levels below safe levels of toxicity.

Ventilation to the outside shall not be located in restricted locations for battery systems or BESS (see [Clause 4.2.2.2](#)).

NOTE 1 Some toxic fumes are heavier than air until heated, such as HF that is produced by lithium ion base battery technology. As such both inlet and outlet vents need to be considered.

NOTE 2 Refer to Safe Work Australia or WorkSafe New Zealand for information regarding workplace exposure standards for airborne contaminants.

### 4.4 System documentation, verification and commissioning

#### 4.4.1 Documentation

##### 4.4.1.1 General

At the completion of the installation of a pre-assembled integrated BESS, documentation shall be provided in accordance with the requirements of this Clause. This documentation shall ensure that key system information is readily available to customers, inspectors, maintenance service providers and emergency service personnel.

##### 4.4.1.2 System manual

A manual, complete with the following items, shall be provided:

- (a) BESS information including:
  - (i) Total battery storage capacity.
  - (ii) Australian/New Zealand address and contact details for the manufacturer representative (or deemed equivalent).
  - (iii) UN Number for the battery cell or battery system.
  - (iv) Commissioning date.
  - (v) System provider contact details.
- (b) A complete list of installed equipment, with model description and serial numbers.

NOTE 1 It is recommended that installers retain records of equipment installed for maintenance and records.

- (c) System performance and operation configuration: system output performance including expected operating response based on programming, expected life of BESS (including information of state of health where provided by the system), end of life system parameters and expected operational life.
- (d) Operating instructions (systems and components): a short description of the function and operation of all installed equipment.



- (e) Operational instructions for response requirements to alarms including earth fault alarms, smoke alarms, ventilation alarms and any other alarms that may be required as part of the installation.
- (f) Description and meaning of any state of health measurements, where provided.
- (g) Shutdown and isolation procedure for emergency.
- (h) Start-up procedure and verification checks.
- (i) Description of how to identify when system is not operating correctly and what to do in the case of a system failure. Details about alarm systems installed as part of the system and in addition to the system.
- (j) Maintenance procedures and schedule: maintenance procedures, a checklist for the installed equipment and schedule for these tasks including hazard mitigation requirements for maintenance tasks. Including shutdown and isolation procedure for maintenance.
- (k) Commissioning records and installation checklist: A record of the initial system settings at system installation, verification records and commissioning checklists for quality assurance.
- (l) System connection diagram: A diagram showing the electrical connections of the BESS. All diagram labels shall match labels provided as per [Section 7](#).

NOTE 2 In larger installations separate schematic circuit and wiring diagrams should be provided.

- (m) Equipment manufacturer's documentation, data sheets, safety data sheets for batteries and handbooks — for all equipment supplied. Where systems have an ethernet or other form of data interface, include all information on connection requirements and system operating manuals.
- (n) Information on specific requirements to address all risks, for example, the action to take when toxic fumes are present.
- (o) List of any spare parts that have been provided (e.g. fuse replacement cartridges).
- (p) Decommissioning information for battery replacement or battery removal.

NOTE 3 An electronic version of documentation is acceptable.

#### 4.4.2 Verification

##### 4.4.2.1 General

The verification of a pre-assembled integrated BESS shall be carried out in accordance with the requirements of AS/NZS 3000 for verification (inspection and testing) prior to energizing and placing the installation into service. The requirements of this [Clause 4.4.2](#) represent minimum standards of inspection and testing to meet the minimum safety requirements for the installation. Upon completion of the verification process a report shall be provided for inclusion in the system documentation (see [Clause 4.4.1](#)).

##### 4.4.2.2 Initial verification and visual inspection

Prior to energizing and placing the installation into service, conformance of the pre-assembled integrated BESS to AS/NZS 3000, the manufacturer's instructions and the following requirements shall be verified:

- (a) All system shutdown and start up notifications shall match system diagrams and system labelling.
- (b) Signs, labels and markings shall be installed and applied in accordance with the requirements of [Section 7](#).

- (c) Any system risk-reduction isolation devices shall operate and be accessible; such as battery system isolators for the purposes of maintenance and future work.
- (d) All terminal connections shall be tightened to the specified torque settings.
- (e) All necessary ancillary safety devices and equipment shall be installed.

#### 4.4.2.3 Alterations and repairs

If there are any alterations to the pre-assembled integrated BESS that result in the device no longer conforming to *Best Practice Guide: battery storage equipment — Electrical Safety Requirements* require that the BESS shall be installed in accordance with [Section 6](#).

NOTE To verify an altered pre-assembled integrated BESS remains in accordance with the *Best Practice Guide: battery storage equipment — Electrical Safety Requirements* a new claim of conformance covering the alteration would need to be issued for the pre-assembled integrated BESS.

Where there is an alteration or repair to a grid connected pre-assembled integrated BESS installation, the electrical installation shall be in accordance with requirements of AS/NZS 4777.1.

Where there is an alteration or repair to a stand-alone pre-assembled integrated BESS installation, the electrical installation shall be in accordance with requirements of AS/NZS 4509.1.

#### 4.4.2.4 Testing

The testing of the installation shall be performed in accordance with the requirements of the pre-assembled integrated BESS manufacturer and the requirements of AS/NZS 3000.

Polarity of any additionally connected d.c. and a.c. devices shall be tested prior to connection to the pre-assembled integrated BESS. Testing shall be carried out to ensure continuity of earth connections. All connections should be verified and measured (where applicable, such as solar PV open circuit voltages) and included in the documentation.

#### 4.4.3 Commissioning

##### 4.4.3.1 General

Any commissioning requirements of the manufacturer shall be followed. System commissioning shall include verification that the system as a whole operates and the pre-assembled integrated BESS operates in both charge and discharge modes.

At installation commissioning, any d.c. connections shall be tested while the system is operating at full discharge or charge current to identify any high resistance connections. For example, voltage measurement across terminal, temperature measurement or infrared imaging of connections or terminals.

Operational parameters that are configured at installation for the control of the pre-assembled integrated BESS shall be verified (whether this is done through the PCE directly or through a data connection or host computer connection). Remote monitoring, where included with the BESS, should be configured so access is available to the system owner or nominated representative.

The system shutdown procedure shall be carried out to ensure this results in safe shutdown of the installation.

#### 4.4.3.2 Induction

An induction shall be provided to the system owner or nominated representative. The induction shall include the following:

- (a) Demonstration of the system shutdown and start up procedures including review of shutdown procedure sign.
- (b) Introduction to the system manual that applies to the installation.
- (c) Provision of detailed information for any alarm features included in the system.
- (d) Clear information on contact details for provision of assistance.
- (e) Information pertaining to the access to specific data or hosted system information, including user logins, and available apps or programs.
- (f) Basic operation and design principals.
- (g) Periodic inspection and maintenance requirements.

NOTE Guidance on inspection and maintenance is provided in [Appendix H](#).

PUBLIC COMMENTING DRAFT

DRAFT

## Section 5 Pre-assembled battery systems — Installation, commissioning and documentation

### 5.1 General requirements for pre-assembled battery systems

This Section applies for the installation of lithium ion pre-assembled battery system equipment conforming to the *Best Practice Guide: battery storage equipment — Electrical Safety Requirements* and in this Section “pre-assembled battery system” means that equipment. Pre-assembled battery system equipment that do not conform with the *Best Practice Guide: battery storage equipment — Electrical Safety Requirements* shall be installed as BESS as per [Section 6](#).

See [Clause 5.4.2.3](#) for requirements on how alterations to the pre-assembled battery system affect the scope of this Section. The pre-assembled battery system and other components that make up the BESS shall be selected such that they are compatible with types of battery technologies used. The pre-assembled battery system and BESS operational parameters and controls shall be configured according to manufacturer’s requirements.

### 5.2 Installation requirements

#### 5.2.1 General

Pre-assembled battery systems shall be installed by competent persons.

Equipment that is mechanically damaged or damaged in any other way shall not be installed.

All the hazards associated with the relevant battery type and all associated components shall be identified. A risk assessment shall be performed prior to planning an installation of a pre-assembled battery system.

NOTE See [Appendix G](#) for additional information on risk assessment.

Each pre-assembled battery system should be installed with reference to the relevant safety data sheets (SDS), manufacturer system hazard information and the manufacturer’s installation, commissioning and maintenance instructions.

Additional enclosure or housing is only required if the pre-assembled battery system installation requires a greater level of protection — based on environment, location, venting or other site issues, as determined by the risk assessment.

#### 5.2.2 Location

##### 5.2.2.1 General

Pre-assembled battery systems shall be protected from mechanical damage, environmental and other external influences. Where the location chosen may expose the pre-assembled battery system to influences that might be reasonably expected then they should be considered as part of the installation conditions, e.g. damage caused by a vehicle if a system is being installed in a carport or garage.

Pre-assembled battery systems shall be installed in accordance with the manufacturer’s instructions.

The location of the pre-assembled battery system shall provide —

- (a) access to connections and any serviceable equipment; and
- (b) unobstructed access to doors and panels that are required to be accessed for installation and maintenance purposes.

The installation of pre-assembled battery system shall conform to the requirements for damp situation as defined by Section 6 of AS/NZS 3000.

Pre-assembled battery system locations shall be determined by outcome of the risk assessment (see [Clause 5.2.1](#)).

Pre-assembled battery systems shall not be installed —

- (i) in ceiling spaces;
- (ii) in wall cavities;
- (iii) on roofs, except where specifically deemed suitable;
- (iv) under stairways; or
- (v) under access walkways.

In areas of domestic or residential electrical installations, the pre-assembled battery systems shall not be located in habitable rooms.

Suitable areas may include garages, storage rooms, a dedicated battery system room and verandas.

Installation of pre-assembled battery systems should also take into account requirements for spacing between —

- (A) multiple battery systems; and
- (B) battery systems and other BESS equipment.

#### 5.2.2.2 Restricted locations

A pre-assembled battery system shall not be installed —

- (a) in restricted locations as defined for switchboards in [AS/NZS 3000](#);
- (b) within 600 mm of any exit;
- (c) within 600 mm any hot water unit, air conditioning unit or any other appliance not associated with the pre-assembled battery system; or
- (d) within 1200 mm below any of the items included in (b) and (c).

A pre-assembled battery systems shall not be installed below, or within 600 mm of the vertical side of, any window and building ventilation opening.

[Figure 5.1](#) shows the restricted zones for equipment of this Clause.

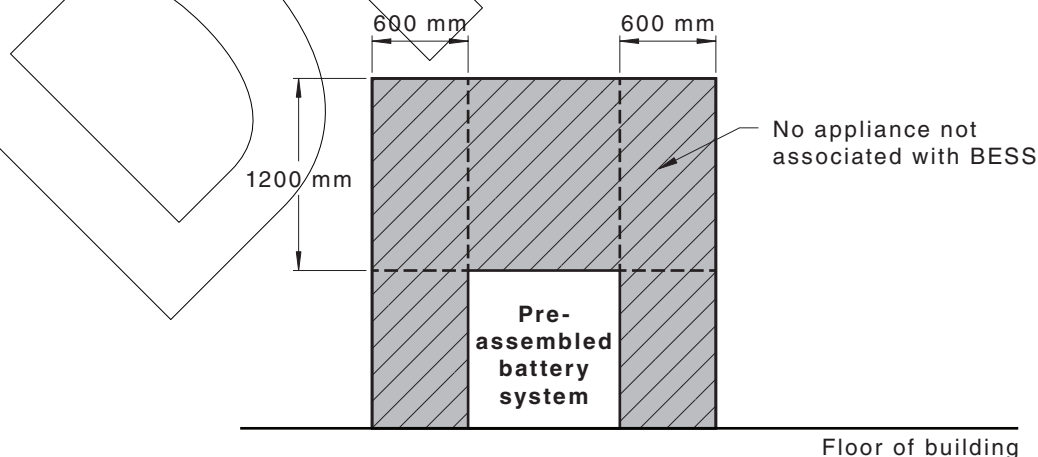

**Figure 5.1 — Restricted zones for equipment not associated with the Battery systems**

A pre-assembled battery system installed in any corridor, hallway, lobby, or the like, leading to a fire exit shall ensure sufficient clearance from the battery system for safe egress, and be no less than 1 m.

A pre-assembled battery system is considered a source of ignition therefore shall not be installed within hazardous area for gas cylinders containing heavier-than-air gasses and gas relief vent terminal as defined in Section 4 of AS/NZS 3000.

### 5.2.3 Environmental requirements

#### 5.2.3.1 General

Pre-assembled battery systems shall not be installed in locations where they will be exposed to temperatures lower than the minimum or greater than the maximum temperatures, as specified by the battery system manufacturer.

The pre-assembled battery system shall be selected and installed to provide protection against damage that might reasonably be expected from the presence of water, high humidity, dust, vermin or solar radiation (direct sunlight).

Pre-assembled battery system should be installed in locations that avoid localized or general heat sources (such as sunlight, generators, steam pipes, space heaters and against uninsulated walls heated from direct sunlight). The flow of heated air from any appliance should be directed away from and not impact on the pre-assembled battery systems.

A pre-assembled battery system should not be located near combustible materials.

#### 5.2.3.2 IP rating

Pre-assembled battery system installation shall have protection against ingress of solid foreign objects and against ingress of water. The pre-assembled battery system shall have an IP code rating as specified in IEC 60529 for the environment in which it is to be installed.

Pre-assembled battery systems shall have a minimum protection of IP2X.

Pre-assembled battery systems installed outdoors shall have an IP rating suitable for the location and be at least IP23.

NOTE 1 The installation of pre-assembled battery system enclosures indoors may have other restrictions based on their identified hazards.

NOTE 2 IP23 is the minimum and AS/NZS 3000 may require higher rating depending on location. For example, due to the environment not being fully sealed from the effects of weather, or having water or other liquid storage system in the same location, or being in the vicinity of areas where use of a hose or washing activity of any kind may occur, or having water taps or the like.

### 5.2.4 Protection against the spread of fire

#### 5.2.4.1 General

Selection and installation of pre-assembled battery system equipment shall not contribute to or propagate a fire in accordance with AS/NZS 3000:2018 Clause 1.5.12.

NOTE This requirement is not specifically for the fire hazard of [Table 3.1](#) that is covered in [Clause 5.3.3](#).

### 5.2.4.2 Barrier to habitable rooms

For the purposes of this Clause, a surface or barrier material is considered suitably non-combustible if the material is deemed to be not combustible when tested in accordance with AS 1530.1. Materials exempt from the need to be tested to AS 1530.1 as considered to be suitably non-combustible are —

- (a) brick or masonry block;
- (b) concrete;
- (c) steel of at least 0.2 mm thickness; and
- (d) ceramic or terracotta tiles.

The material shall have no vents or perforations within the zone required to be covered by the barrier. Any penetration of the barrier that has an internal free space greater than 5 mm diameter shall be sealed with a fire retardant sealant.

To protect against the spread of fire to habitable rooms, where the pre-assembled battery system is mounted on, or placed against, a surface of a wall or structure that has a habitable room on the other side, the wall or structure shall be a suitably non-combustible barrier. If the mounting surface itself is not made of a suitably non-combustible material, a non-combustible barrier shall be placed between the pre-assembled battery system and the surface of a wall or structure.

Where the preassembled battery system is located on, or mounted on the floor within 300 mm of, the wall or structure separating it from the habitable room, the barrier shall extend —

- (i) 600 mm beyond the vertical sides of the pre-assembled battery system;
- (ii) 1200 mm above the pre-assembled battery system; and
- (iii) to the extent of the bottom of the pre-assembled battery system.

NOTE See [Figure 5.2](#) and [Appendix E](#) for typical layout examples.

Where the top of the pre-assembled battery system is within 1200 mm of the ceiling or structure above the BESS, the ceiling or structure surface shall be suitably non-combustible for an area of 600 mm past the extremities of the pre-assembled battery system.

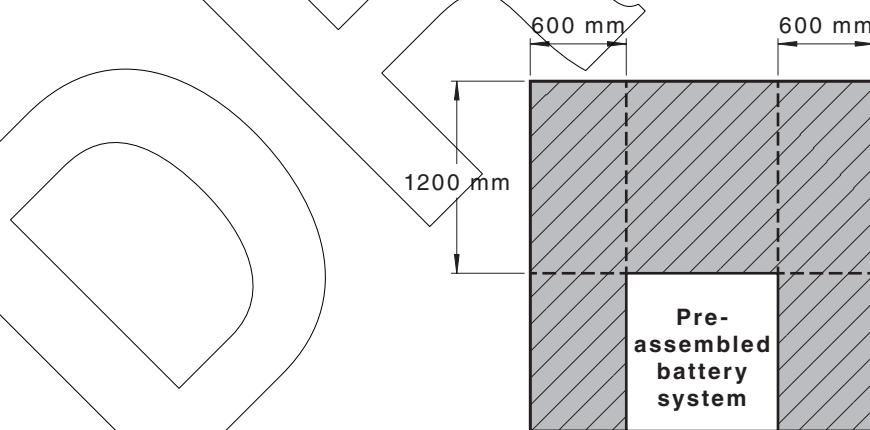

**Figure 5.2 — Barrier zones for pre-assembled battery systems installed on or near a habitable room facing wall**



**DRAFTING NOTE for public comment**

The background to this Clause 5.2.4 and the additional requirement of ensuring the battery system is located to reduce any fire spread is:

- The technology for battery system for mass market situations is still emerging and is relatively new. Experience of issues of the equipment and installation processes that ensures any fire risk is fully minimised, is still being developed and enhanced.
- Battery system equipment conforming to the Best Practice Guide have assessment for resistance to fire propagation, and therefore there is a level of confidence the equipment has addressed known and identified fire risks related to the equipment — this is reflected in this battery system equipment not classified as “fire hazard” in Table 3.1.
- Nevertheless, as with all electrical equipment there remains a small residual fire risk and so it is prudent to apply installation requirements to address that residual risk.

This clause has a simple proposal to reduce any residual fire risk by having the battery system located such that, in the rare event a fire might occur, the equipment will either be located against a wall that does not have a habitable room on the other side or, if a habitable room is on the other side of the wall, there is material to prevent fire burning through into the habitable room.

This clause is a simple easy to achieve location or surface material requirement, it is not intended to require a special room to be built, or for an onerous requirement of fire proofing the battery system in an additional enclosure, or of placing the battery system in a separate fire proof cabinet or box.

**5.2.5 Pre-assembled battery system room requirements**

Where pre-assembled battery systems are installed within a room, they shall be located so that access to a battery system is not obstructed by the structure of the building, the fixtures and fittings within the room.

The room should be clean, dry and ventilated and provide and maintain protection against detrimental environmental conditions and other external factors. In addition the room should be selected to minimize likelihood of a build-up of other materials around or on the pre-assembled battery system, or an infestation of insect or vermin, or similar issues occurring that may cause a hazard.

The size of the room shall allow for sufficient clearance around the pre-assembled battery systems to provide safe handling and access for installation and maintenance.

The design, layout and construction of the pre-assembled battery system room shall include means to prevent access by unauthorized personnel unfamiliar with the hazards of battery systems.

The room's entry doors and panels shall open in the direction of egress and allow unobstructed access to the pre-assembled battery system for installation and maintenance purposes.

The minimum unimpeded access on the working side of the battery system enclosure shall be either —

- (a) 900 mm with doors open; or
- (b) 600 mm with doors open for battery systems that have —
  - (i) voltage no greater than DVC-A;
  - (ii) a calculated arc flash energy at the output terminals of the battery system not greater than 4.0 cal/cm<sup>2</sup>;
- (c) or the clearance specified by the manufacturer whichever is the greater.

Pre-assembled battery systems shall be mounted with the highest point no greater than 2.2 m above the floor or platform level.



## 5.2.6 Seismic (earthquake) forces

Depending on location/application, the pre-assembled battery system may need to be installed to withstand seismic (earthquake) forces.

For Australia, where the pre-assembled battery system is installed in, or on, a building that is required to be designed for earthquake action, the earthquake action requirements for the pre-assembled battery system shall be in accordance with AS 1170.4.

For New Zealand, where a higher level of seismic restraint is required, the pre-assembled battery system seismic (earthquake) restraint shall be in accordance with NZS 4219.

The requirements for seismic restraint also mean that tall pre-assembled battery systems should be installed as close as possible to the floor.

For pre-assembled battery system installations the designer should seek advice from a structural engineer or similar.

## 5.3 Installation hazards

### 5.3.1 Electrical hazards

#### 5.3.1.1 General

A BESS shall not be installed if the pre-assembled battery system has a voltage of DVC-A and is connected to an inverter that does not have at least simple electrical separation between the battery system d.c. port and the a.c. or grid port of the inverter.

The cabling and installation requirements of the pre-assembled battery system shall be treated as DVC-C if a non-separated PCE other than an inverter is installed (e.g. solar charge controller) and the non-battery side of the PCE is greater than DVC-A.

#### 5.3.1.2 Overcurrent protection from battery system

##### 5.3.1.2.1 General

Overcurrent protection shall be installed in all live conductors (excluding control and monitoring circuits) in all battery systems. The overcurrent protection shall be located so as to minimize the length of the unprotected cable from the battery system.

The overcurrent device shall —

- (a) be of the non-polarized type;
- (b) be d.c. rated;
- (c) have a voltage rating greater than the battery system's maximum voltage under all normal and abnormal operating conditions;
- (d) meet the requirements of Section 2 of AS/NZS 3000; and
- (e) have a current rating to protect the cabling from the pre-assembled battery system.

NOTE 1 When connected to a system comprising multiple PCEs, the rated current of the BESS is the total sum of the currents that can be supplied from the PCEs to the battery system or the maximum rated current of the PCEs required to operate from the battery system.

Protective devices may be integrated into pre-assembled battery systems (see [Clause 5.3.1.2.4](#)) or, if added externally, should be selected from the following:

- (i) Fuses having enclosed fuse-links (high rupturing capacity (HRC) fuses).

(ii) Miniature circuit breakers (MCBs) or moulded case circuit-breakers (MCCBs).

NOTE 2 MCBs and some MCCBs have limited d.c. short-circuit current ratings and may require back up by HRC fuses.

Where parallel pre-assembled battery systems are installed, each battery system shall include a separate overcurrent protective device. This is to prevent discharge from one battery system into a parallel battery system if a fault occurs in one battery system.

#### 5.3.1.2.2 Requirements for circuit breakers

In addition to the requirements specified in [Clause 5.3.1.2.1](#), circuit breakers used for overcurrent protection shall be in accordance with either AS/NZS 60898.2 or AS/NZS IEC 60947.2.

Circuit breakers shall be mounted in enclosures that have a minimum rating of IP23.

Circuit breakers for outdoor use shall be suitably rated for ambient temperature of 40 °C and should be mounted in enclosures that have a minimum rating of IP56.

The selection and connection of circuit breakers shall take into account the applied voltage when the system is earthed and unearthed.

NOTE It may be necessary to take into account whether earth is connected to the positive or the negative pole of the battery system, or whether earth is connected to a centre tap or similar.

#### 5.3.1.2.3 Requirements for HRC fuses and holders

In addition to the requirements specified in [Clause 5.3.1.2.1](#), HRC fuses and holders used for overcurrent protection for battery systems shall —

- (a) be in accordance with IEC 60269-1 and IEC 60269-3 or AS/NZS IEC 60947.1 and AS 60947.3;
- (b) be mounted in a purpose built fuse holder;
- (c) not be a type able to be rewired;
- (d) require a tool to access live parts or terminals; and
- (e) be mounted in a fuse holder providing the minimum degree of protection of IP4X.

Fuse and fuse holder that are not rated for load breaking shall be installed to provide restricted access and labelled as per [Clause 7.13.3](#).

#### 5.3.1.2.4 Pre-assembled battery systems which include overcurrent protection

Pre-assembled battery system protection devices may meet the requirements for overcurrent protection of the output cables from the battery system where —

- (a) the pre-assembled battery system includes overcurrent protection in all live conductors (excluding control and monitoring circuits);
- (b) the pre-assembled battery system includes overcurrent protection that is a readily available circuit-breaker or HRC fuse;
- (c) the pre-assembled battery system manufacturer's instructions permits the use of the pre-assembled battery system overcurrent protection to meet the overcurrent protection requirements of the battery system output cables; and
- (d) the output cables have a current carrying capacity greater than the rating of the protection device.

### 5.3.1.2.5 Location of overcurrent protection devices

Where an external overcurrent protection device is required, overcurrent protection shall be —

- (a) installed as close as practical to the output terminals of the battery system but no greater than 2 m away; and
- (b) readily available.

### 5.3.1.3 Isolation of the pre-assembled battery system

#### 5.3.1.3.1 General

All pre-assembled battery systems shall be capable of being electrically isolated from all other equipment within the BESS. Isolation devices shall be capable of being secured in the open position. The isolation device shall operate simultaneously in all live conductors. The isolation device shall be capable of load breaking.

The overcurrent protection device, may also perform the function of the isolation device provided it is rated for isolation function.

Where a pre-assembled battery system includes an internal non-serviceable battery management system, the point of isolation shall be after the output terminals of the battery system.

#### 5.3.1.3.2 Pre-assembled battery systems internal isolation

The preassembled battery system may include an internal isolation device operating in all live conductors. Where an internal isolation device provides the same functions as for an adjacent isolation device, no additional adjacent isolation device is required.

#### 5.3.1.3.3 Parallel battery systems

For battery energy storage systems where there are two or more pre-assembled battery systems connected in parallel, each pre-assembled battery system shall have an isolation device in all live conductors. This isolation device is to facilitate the isolation of one battery system for maintenance and allow the continuous operation of the remaining system.

#### 5.3.1.3.4 Requirements for battery system — Switch-disconnector

Switch disconnectors used as a load breaking isolation device shall —

- (a) conform to AS 60947.3;
- (b) be of the non-polarized type;
- (c) be d.c. rated;
- (d) have a voltage rating greater than the battery system's maximum voltage under all operating conditions;
- (e) be rated to withstand the maximum short circuit current;
- (f) have a current rating greater than the maximum rated d.c. current for the BESS;
- (g) be rated to interrupt for full load;
- (h) meet the requirements of Section 2 of AS/NZS 3000 for isolating device selection;
- (i) be rated for independent manual operation;
- (j) have a minimum pollution degree 3 classification;

- (k) be able to be secured in the open position, and only secured when the main contacts are in the open position;
- (l) conform to requirements for isolation, including marking requirements for an isolation device; and
- (m) have a utilization category of at least DC21B

Switch-disconnectors for indoor use shall be mounted in enclosures that have a minimum rating of IP23.

Switch-disconnectors for outdoor use shall be mounted in enclosures that have a minimum rating of IP56NW when tested under conditions of Clauses D.8.3.13.4, D.8.13.3.5, D.8.13.3.6, D.8.13.3.7 and D.8.13.3.8 of AS 60947.3:2018. Switch-disconnectors for outdoor use shall be suitably rated for ambient temperature of 40 °C.

#### 5.3.1.3.5 Location of isolation devices

Where an external isolation device is required, the isolation device shall be —

- (a) installed as close as practical to the output terminals of the battery system but no greater than 2 m away; and
- (b) readily available.

NOTE In battery system rooms, the treatment of the entrance and access to isolation devices for emergency services personnel may mean that the devices are located near the entrance door.

#### 5.3.1.4 Battery system wiring to PCE

##### 5.3.1.4.1 General

Wiring between the battery system and PCE should be installed in a way to minimize effects of inductive loops.

The cable from the battery system to the overcurrent protection device shall have no other devices connected other than monitoring and control circuits.

##### 5.3.1.4.2 Type of cable

Battery system cables shall be in accordance with —

- (a) AS/NZS 5000.2 (450/750 V insulation) for battery systems with a maximum operating voltage less than 450 V d.c.;
- (b) AS/NZS 5000.1 (0.6/1 kV insulation) for battery systems with a maximum operating voltage less than 600 V d.c.; or
- (c) IEC 62930 for battery systems with a maximum operating voltage less than 1500 V d.c.

NOTE IEC 62930 is for photovoltaic systems, however, it covers cables sizes up to 400 mm<sup>2</sup> and 1500 V d.c. rating and is suitable for battery systems.

Wiring between the battery system and the PCE shall meet the requirements of AS/NZS 3000 for selection and installation of wiring systems.

The cable from the battery system to the PCE shall be —

- (i) double insulated if the voltage exceeds DVC-A; and
- (ii) double insulated for DVC-A battery system connected to a non-separated PCE (e.g. solar charge controller) and the non-battery side of the PCE is greater than DVC-A.

The cable between the battery system, the overcurrent protection device and the PCE should be double insulated for all battery systems operating at DVC-A.

#### 5.3.1.4.3 Mechanical protection

All cables that exit a pre-assembled battery system without internal overcurrent protection shall be mechanically protected by at least medium duty conduit or equivalent protection up to overcurrent protection device.

NOTE Refer to AS/NZS 3000:2018, Clause H4 for mechanical protection of cables.

#### 5.3.1.4.4 Voltage drop

The voltage drop between the battery system and the PCE should be no more than 2 % based on the rated d.c. battery port current of the PCE and shall be no more than 5 % under any operating condition.

NOTE Voltage drop impacts the settings for charge and discharge control of the battery system and to ensure safe charging and discharging of the battery system needs to be taken into account in setpoints.

#### 5.3.1.4.5 Current-carrying capacity

The current-carrying capacity of the pre-assembled battery system's cable to the overcurrent protection device shall be rated to —

- (a) the maximum current rating of the pre-assembled battery system; and
- (b) the short circuit current and the duration from the pre-assembled battery system.

The current carrying capacity of the pre-assembled battery system cables to the PCE shall be greater than the rating of the overcurrent protection devices installed (see [Clause 5.3.1.2](#)).

The minimum cable sizes for pre-assembled battery system wiring, shall be based upon the current carrying capacity of the relevant flexible cables as specified in —

- (i) AS/NZS 3008.1 series; or
- (ii) as specified by the manufacturer of the cable.

NOTE AS/NZS 3008.1 series applies to a.c. cables, but for the purposes of this Standard, the current rating tables and calculations are relevant also for d.c.

#### 5.3.1.4.6 Parallel battery systems

For a BESS consisting of two or more pre-assembled battery systems connected in parallel, the output cable from each battery system to a point where the parallel battery systems connect (e.g. PCE or junction box), shall have equal cable resistance. This can be achieved by the cables, which connect the battery systems to a common connection point, being of equal length, equal cross-sectional area and conductor materials.

**Exception — This requirement does not apply where there is a BMS or similar device that provides managed voltage and current charge/discharge to each separate system.**

### 5.3.1.5 Isolation of PCE from battery system

#### 5.3.1.5.1 General

PCEs shall be capable of being isolated from the pre-assembled battery system for the purpose of maintenance, repair and fault-finding. Where a switch-disconnector is used for this purpose it shall conform to [Clause 5.3.1.3.4](#). Where a circuit breaker is used for this purpose it shall conform to [Clause 5.3.1.2.2](#) and be rated for isolation function.

### 5.3.1.5.2 BESS with single PCE

If the PCE is not adjacent to the battery system(s), a separate isolation device shall be installed adjacent to the PCE to isolate the PCE.

### 5.3.1.5.3 BESS with multiple PCEs

When a BESS includes multiple PCEs (e.g. a solar charge controller and an inverter; or multiple inverters), a separate isolation device shall be installed adjacent to each PCE.

### 5.3.1.5.4 PCE with internal isolation device

The PCE may include an internal isolation device operating in all live conductors. Where an internal isolation device provides the same functions as for an adjacent isolation device and the internal isolation device meets one of the following requirements:

- (a) An isolation device that is mechanically interlocked with a replaceable module of the PCE, and allows the module to be removed from the section containing the isolation device without risk of electrical hazards.
- (b) All live parts are inside enclosures or behind barriers that provide a degree of protection of at least IPXXB or IP2X (i.e. all live parts are screened from touch).

Where an internal isolation device meets these requirements no additional adjacent isolation device is required.

### 5.3.1.6 Segregation of circuits

In addition to the segregation requirements of Section 3 of AS/NZS 3000, segregation shall be provided between d.c. and a.c. circuits within enclosures such that connections and pathways are physically segregated from each other by an insulating barrier(s). DC wiring shall not be installed or pass through a.c. switchboards or enclosures unless segregated by means of an insulating barrier, such as conduit or trunking.

Where devices such as switches for circuits requiring segregation are mounted on a common mounting rail in an enclosure, this rail shall not be metallic or conductive unless the entire enclosure is metallic.

Segregation insulation barriers between the d.c. and a.c. circuits shall be equivalent to double insulation for the highest voltage level present and compatible with the installation environment.

The different types of circuits shall be clearly identified (e.g. by labels and, where possible, by use of different coloured cables).

Outside of enclosures, a separation of 50 mm or a segregation insulation barrier between a.c. and d.c. circuits shall be provided.

Segregation insulation barriers between the d.c. and a.c. circuits shall be to the level required for the installation environment and not less than IP4X.

### 5.3.1.7 Earthing of the battery systems

#### 5.3.1.7.1 General

The four categories of earthing arrangements for battery systems connected to inverters are listed as follows and specific requirements for each system are listed in the referenced clauses:

- (a) Floating/separated, i.e. not earthed and not referenced to earth. See [Clause 5.3.1.7.2](#).
- (b) Direct earthed. See [Clause 5.3.1.7.3](#).



- (c) Resistive earthed. See [Clause 5.3.1.7.4](#).
- (d) Battery system connected to a non-separated inverter (i.e. referenced to the a.c. grid and therefore to earth by the inverter's internal connections). See [Clause 5.3.1.7.7](#).

Where the electrical installation earthing is not rated to carry the fault current of the battery system, the battery system earth cable shall be connected to the earth electrode.

The PCE and pre-assembled battery system manufacturer's instructions should be followed to determine the best earthing arrangement.

Pre-assembled battery systems connected to inverters that do not have separation between the d.c. port and the a.c. port or grid port, shall not be earthed.

The battery isolator shall have at least one pole for each live conductor including the conductor that is earthed. For example, if the system comprises a centre tapped earth then a 3 pole switch-disconnector is required for breaking simultaneously the two battery system output cables and the centre tapped earth.

### 5.3.1.7.2 Floating/separated

Floating battery system connected to a separated inverter is where the battery system is not earthed and is not referenced to earth (see [Figure 5.3](#)).

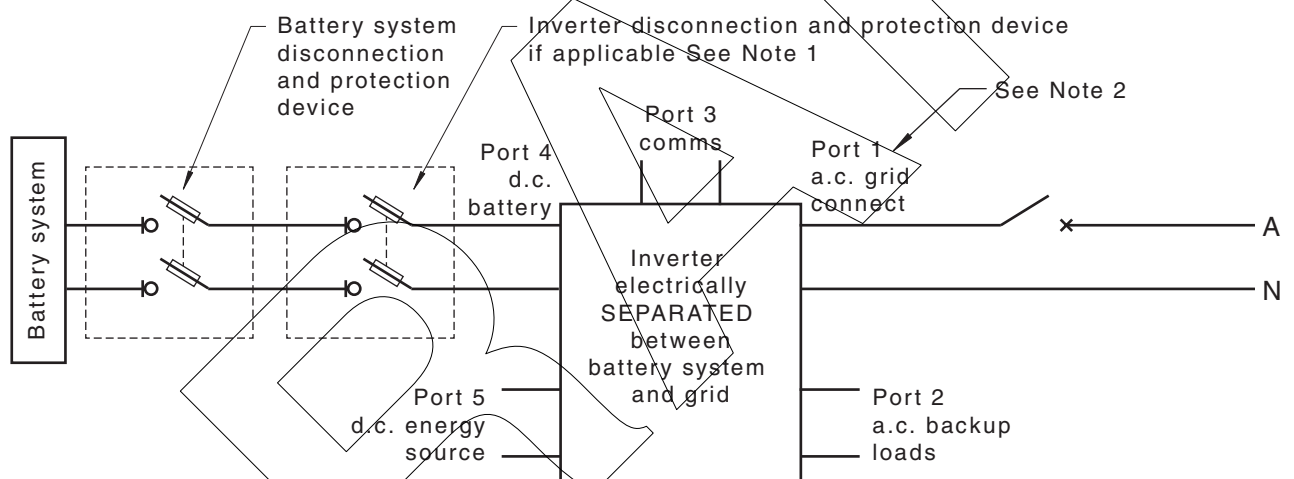

NOTE 1 PCE disconnection device required if the battery system disconnection device is not adjacent (see [Clause 5.3.1.5](#)).

NOTE 2 Port 1 is the a.c. port shown for a grid-connected system. This port could also be the input from a generator.

NOTE 3 In this case the battery is separated from the mains and from earth and is said to be "floating".

NOTE 4 Earth fault alarm (see [Clause 5.3.1.9](#)) required for battery systems greater than DVC-A.

**Figure 5.3 — BESS installation diagram: floating battery system connected to a separated inverter**

As the pre-assembled battery system is separated from earth (i.e. floating) and the PCE is electrically separated from the output application circuit there is no additional earthing requirements except for earth fault monitoring (see [Clause 5.3.1.9](#)).

**5.3.1.7.3 Earth connection requirements — Direct earthed**

A direct earthed battery system is a battery system, with a direct earth connection, connected to an inverter providing separation from the grid (see [Figure 5.4](#)).

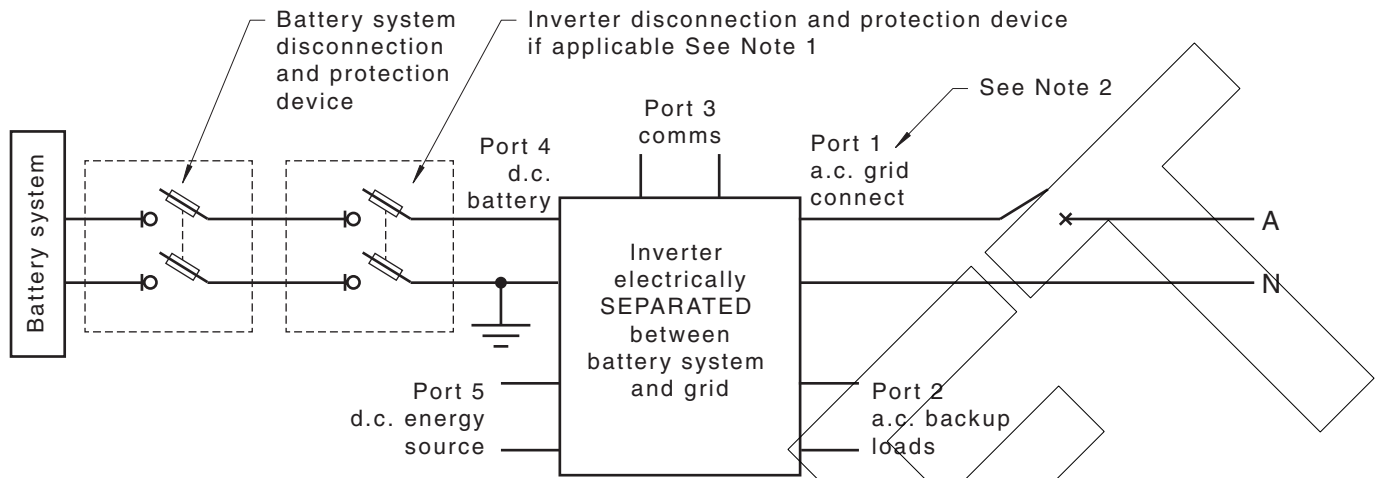

NOTE 1 PCE disconnection device required if the battery system is not adjacent (see [Clause 5.3.1.5](#)).

NOTE 2 Port 1 is the a.c. port shown for a grid-connected system. This port could also be the input from a generator.

**Figure 5.4 — BESS installation diagram: battery connected to an inverter providing separation from the grid with a direct earth connection**

For directly earthed pre-assembled battery system, one conductor of the battery system shall be connected to the installation earthing system (see [Figures 5.6 to 5.11](#)). The pre-assembled battery system earthing conductor shall be rated to withstand the prospective earth fault current of the battery system for a time at least equal to the operating time of the associated overcurrent protective device (see [Clause 5.3.1.7.7](#)).

NOTE The installation earthing system needs to be checked as per [Clause 5.3.1.7.1](#).

**5.3.1.7.4 Earth connection requirements — Resistive earthed**

A resistive earthed battery system is a battery system, with a resistor inserted in series with the earth connection, connected to an inverter providing separation from the grid (see [Figure 5.5](#)).

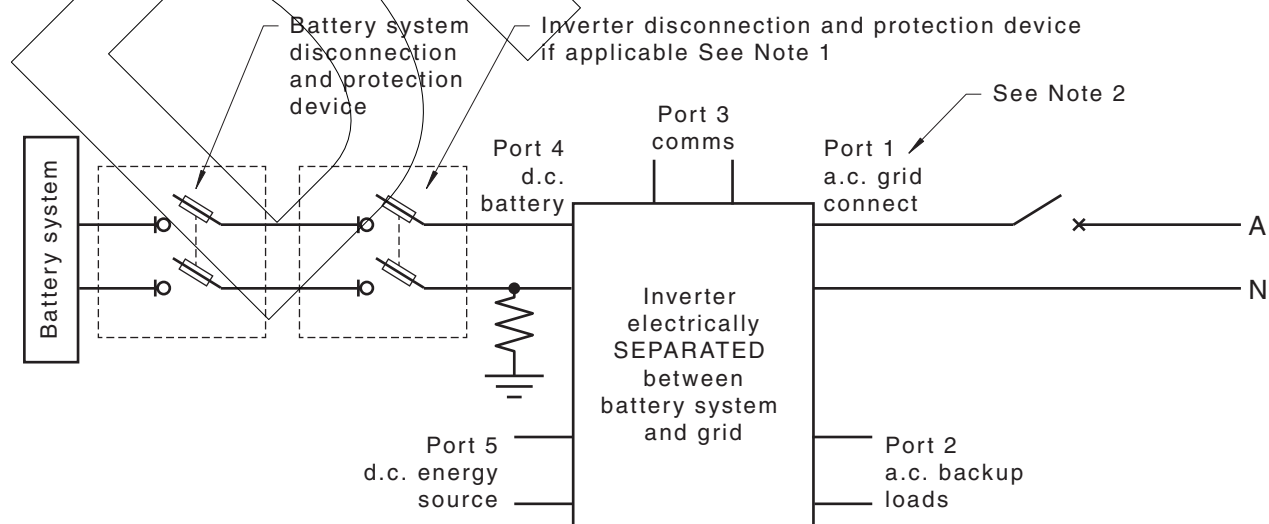

NOTE 1 PCE disconnection device required if the battery system is not adjacent (see [Clause 5.3.1.5](#)).

PUBLIC COMMENTING DRAFT



NOTE 2 Port 1 is the a.c. port shown for a grid-connected system. This port could also be the input from a generator.

NOTE 3 Earth fault alarm (See [Clause 5.3.1.9](#)) required for battery systems greater than DVC-A.

### Figure 5.5 — BESS installation diagram: battery connected to an inverter providing separation from the grid with resistive earth connection

For resistively earthed pre-assembled battery system, one conductor of the battery system shall be connected to the installation earthing system via a resistor (see [Figures 5.6](#) to [5.11](#)). The pre-assembled battery system earthing conductor shall be rated to withstand the prospective earth fault current of the battery system continuously.

NOTE In a resistively earthed system the prospective earth fault current is significantly reduced by the use of the resistor and may not trip the overcurrent protection.

#### 5.3.1.7.5 Battery system connected to a non-separated inverter

For pre-assembled battery systems connected to a non-separated inverter, no conductor of the battery system shall be connected to the installation earthing system. This is a battery system connected to a non-separated inverter and no conductor of the battery system is earthed and is referenced to earth through the non-separated inverter (see [Figure 5.6](#)).

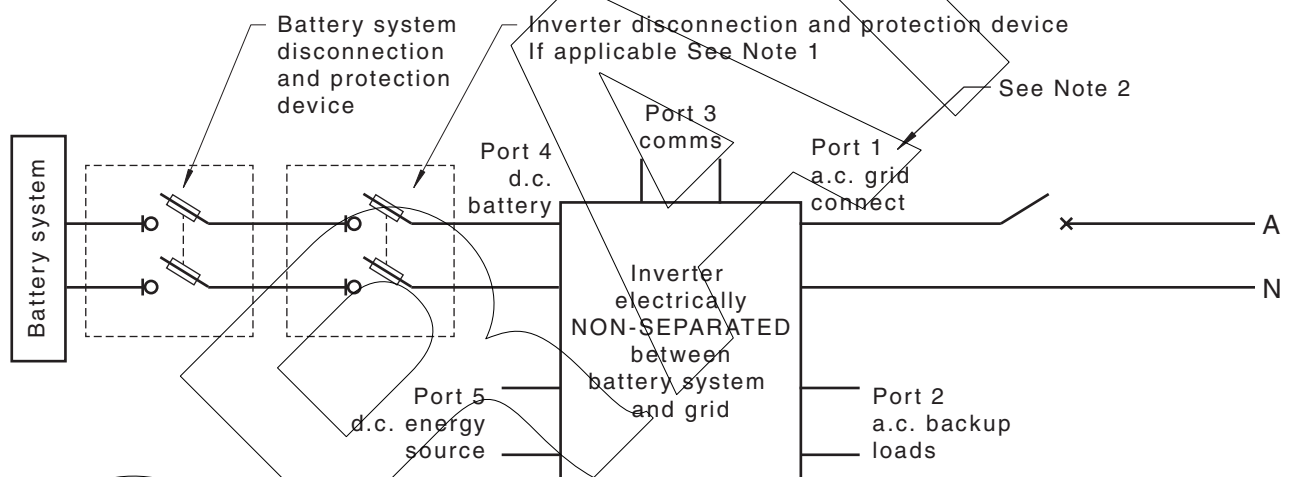

NOTE 1 PCE disconnection device required if the battery system disconnection device is not adjacent (see [Clause 5.3.1.5](#)).

NOTE 2 Port 1 is the a.c. port shown for a grid-connected system. This port could also be the input from a generator.

NOTE 3 In this case the battery is NOT separated from the mains as there is a connection internally in the inverter between the grid connect port and the battery system.

NOTE 4 If a pre-assembled battery system has a voltage of DVC-A it cannot be connected to a non-separated inverter ([Clause 5.3.1.1](#)).

### Figure 5.6 — BESS installation diagram: battery system connected to a non-separated inverter

#### 5.3.1.7.6 Battery system earth location

The earth connection shall be on the PCE side of the battery system isolator (see [Figure 5.7](#)). Isolating the pre-assembled battery system from the PCE and earth connection provides an isolated battery system that is floating, minimizing the electrical hazard during maintenance.

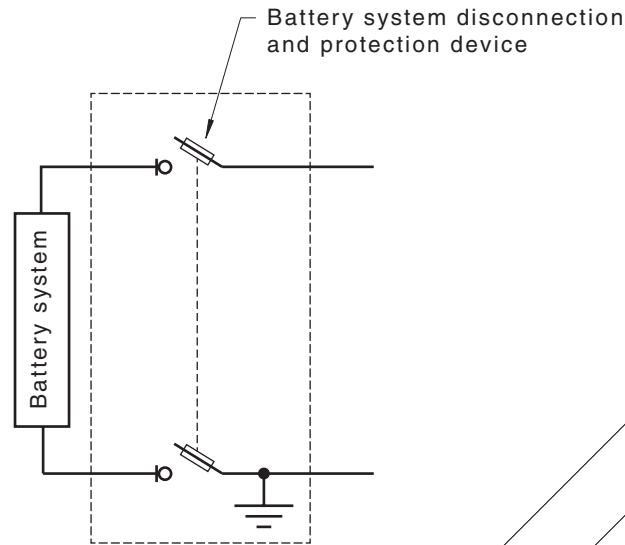

**Figure 5.7 — Location of earth connection on single battery system**

NOTE Where resistive earthing is in use a resistor is inserted in series with the earth connection.

When the BESS comprises multiple parallel battery systems that require earthing, there shall be an earth connection on the PCE side of the pre-assembled battery system isolators as shown in [Figures 5.8 to 5.12](#).

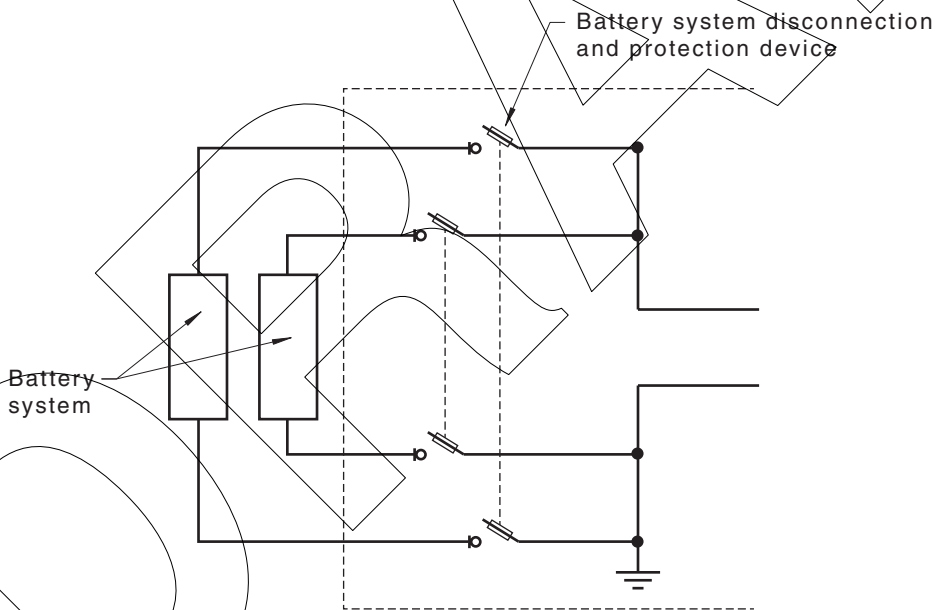

NOTE Where resistive earthing is in use a resistor is inserted in series with the earth connection.

**Figure 5.8 — Location of earth connection on parallel battery systems**

PUBLIC COMMENTING DRAFT

PUBLIC COMMENTING DRAFT

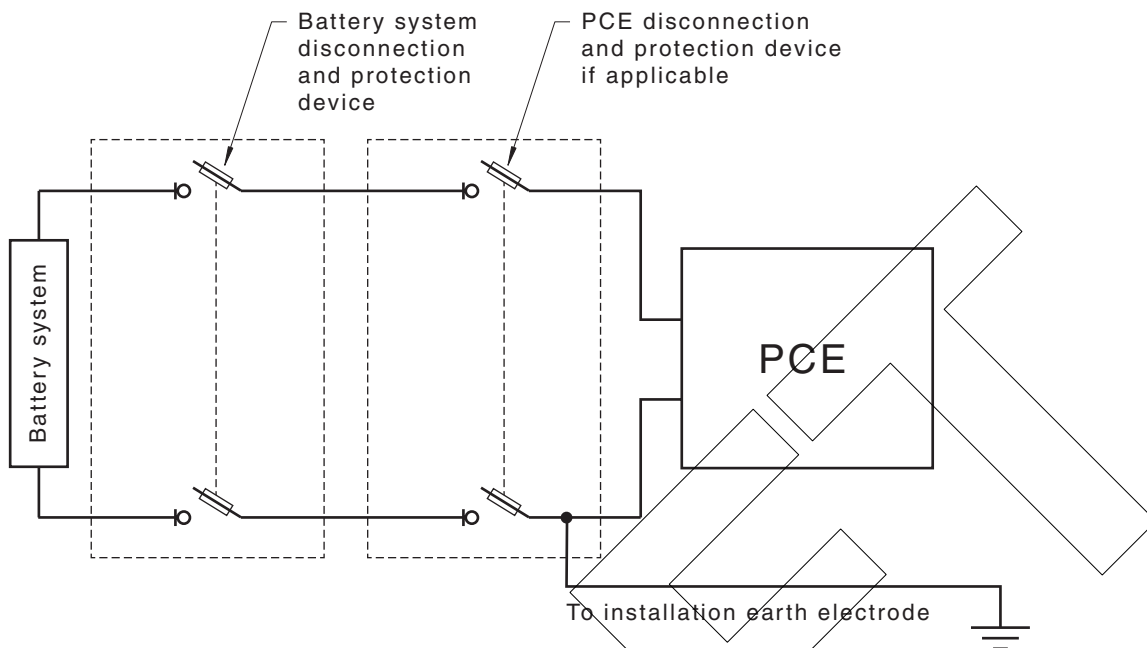

NOTE Where resistive earthing is in use a resistor is inserted in series with the earth connection.

**Figure 5.9 — Battery system earth conductor connected to installation earthing system**

If there are multiple parallel battery systems that are earthed, each system shall have a conductor that is connected to the earthing system via one earth conductor (see [Figure 5.10](#)).

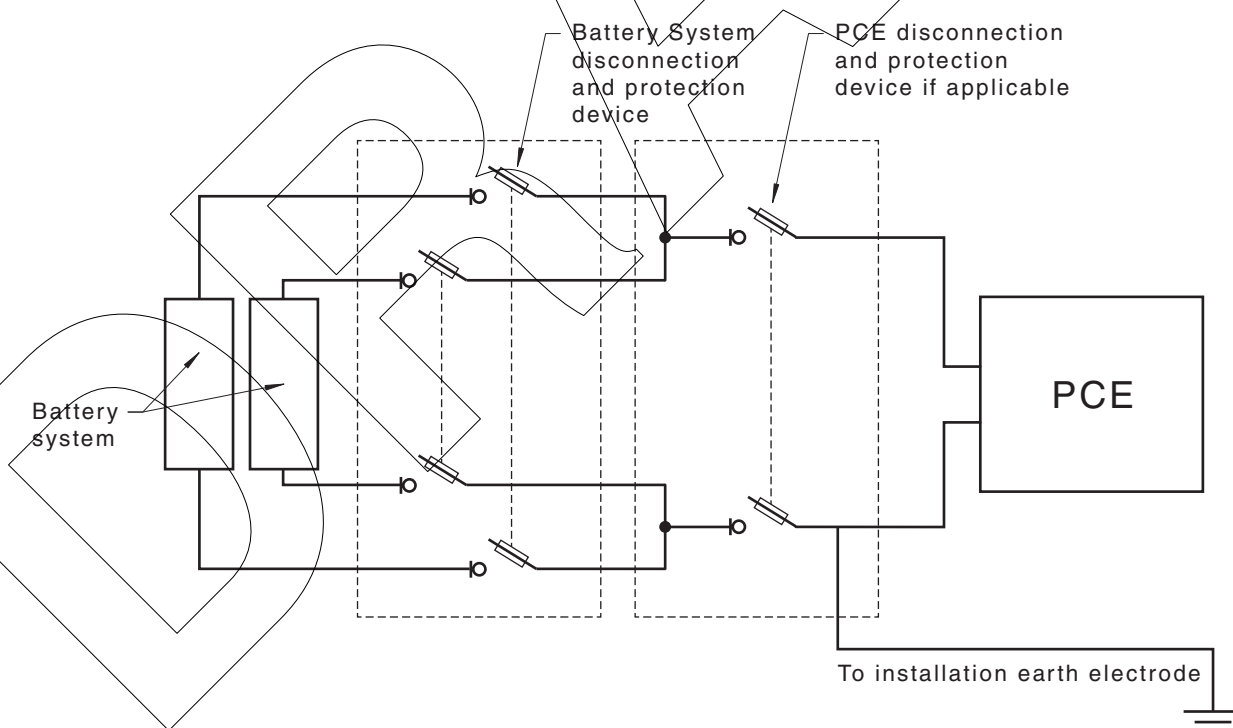

NOTE Where resistive earthing is in use a resistor is inserted in series with the earth connection.

**Figure 5.10 — Multiple battery system earth conductors connected to installation earthing system**

If there are multiple parallel BESSs and each BESS is earthed on the d.c. supply side, each BESS shall have a conductor connected to the earthing system (see [Figure 5.11](#)).

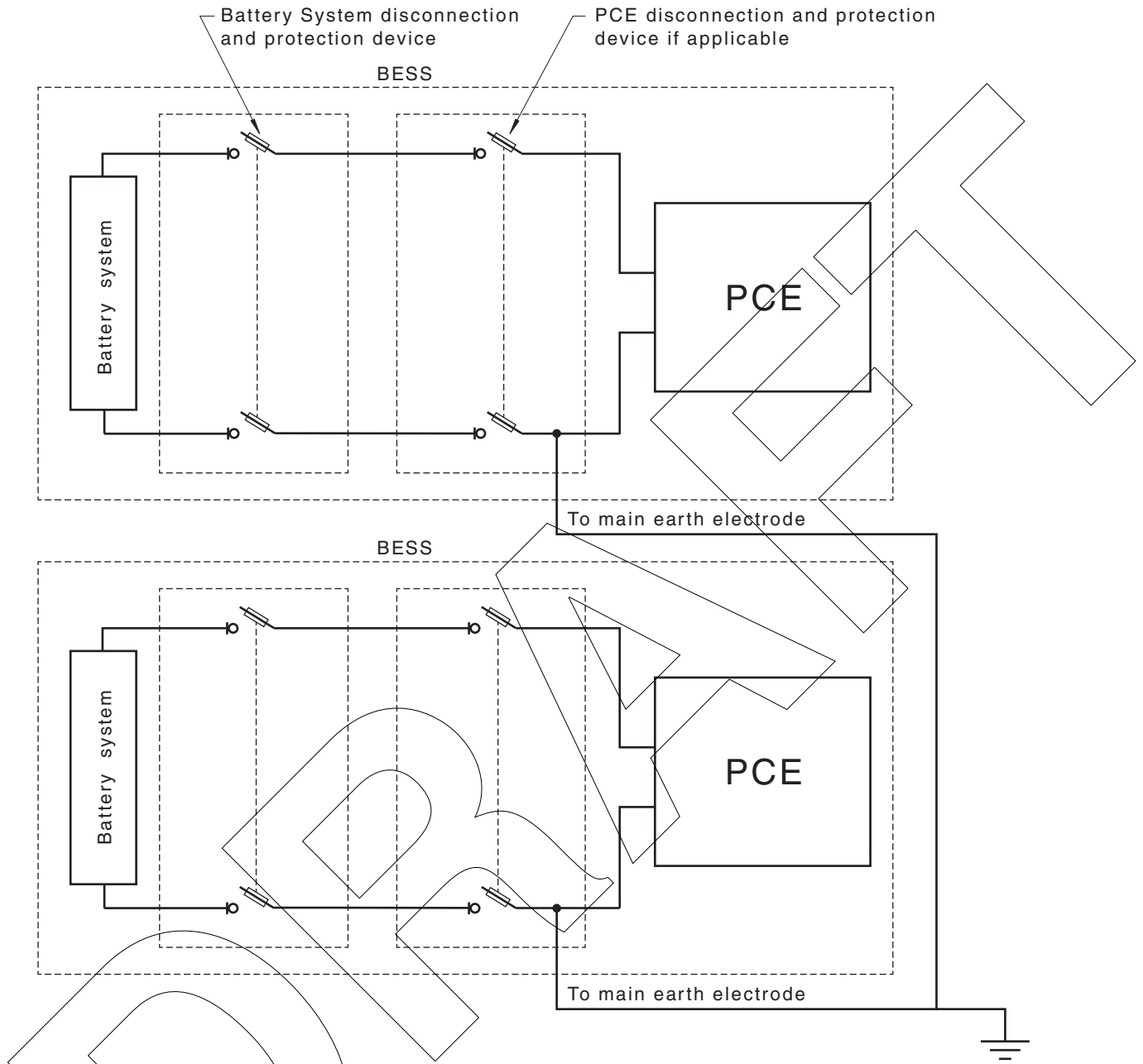

NOTE Where resistive earthing is in use a resistor is inserted in series with the earth connection.

**Figure 5.11 — Multiple BESS earthing conductors connected to installation earthing system**

If there are multiple parallel PCEs and one pre-assembled battery system, the earth conductor between the battery system isolator and all PCE isolators (see [Figure 5.12](#)).

PUBLIC COMMENTING DRAFT

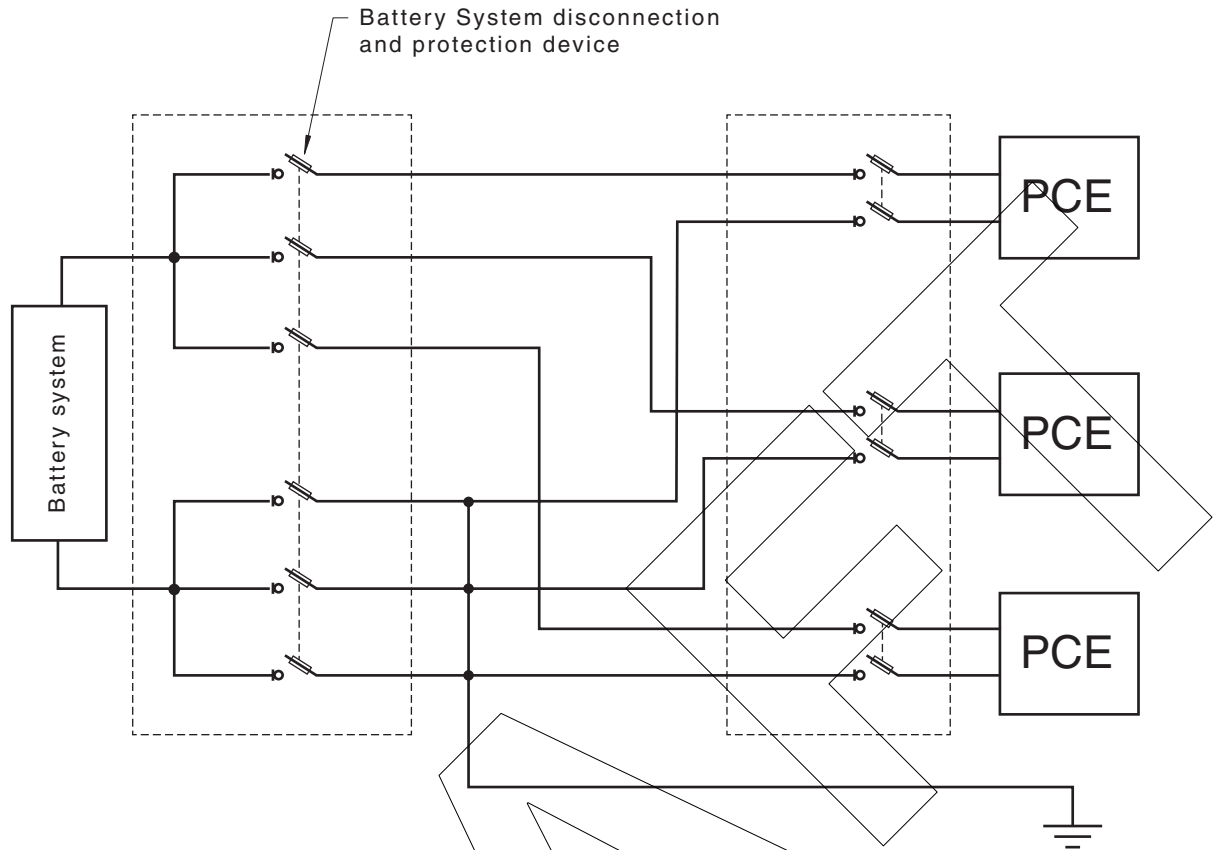

NOTE Where resistive earthing is in use a resistor is inserted in series with the earth.

**Figure 5.12 — Single battery system and multiple PCE earthing conductors connected to installation earthing system**

#### 5.3.1.7.7 Size of earth cable

The earth cable in an earthed battery system shall be sized according to AS/NZS 3000:2018 Clause 5.3.3.1.2, which states that the cable cross-sectional area is required to be determined either —

- (a) from AS/NZS 3000:2018 Table 5.1 in relation to the cross-sectional area of the largest active conductor supplying the portion of the electrical installation to be protected; or
- (b) by calculation in accordance with AS/NZS 3000:2018 Clause 5.3.3.1.3.

When the BESS is earthed at the battery system or PCE, the earth cable size shall be calculated according to Item (b) to carry the maximum earth fault current for a time at least equal to the operating time of the associated overcurrent protective device.

NOTE 1 In the event of unintentional contact of an earth conductor to unearthed (live) parts, the fault current can be significant.

If the BESS comprises multiple parallel battery systems and if there is only one battery system cable connected to the PCE the “nominal size of earth conductor” shall be sized to carry —

- (i) the maximum earth fault current for a time at least equal to the operating time of the associated overcurrent protective device for that cable (see [Figure 5.10](#)); or
- (ii) the sum of the maximum earth fault currents for a time at least equal to the operating time of the associated overcurrent protective device for the individual battery cable (refer to AS/NZS 3000, Section 5) or the sum of the individual battery system battery cables (see [Figure 5.8](#)).

NOTE 2 If there is no single fuse protecting the single cable then Item (ii) applies.

### 5.3.1.8 Earthing system

#### 5.3.1.8.1 General

The pre-assembled battery system shall be earthed according to the manufacturer's instructions.

#### 5.3.1.8.2 Battery system not earthed — bonding

For an installation comprising a single BESS with voltages greater than DVC-A, all metallic equipment enclosures associated with the BESS installation, shall be bonded together and connected to the earthing system of the electrical installation to prevent a shock hazard occurring. The minimum size of the bonding conductor shall be 6 mm<sup>2</sup>.

#### 5.3.1.8.3 Battery system is directly earthed

Where the pre-assembled battery system is directly earthed with voltages greater than DVC-A all metallic equipment enclosures associated with the BESS installation, shall be bonded together and connected to the earthing system of the electrical installation to prevent a shock hazard occurring.

The minimum size of the bonding conductor shall be 6 mm<sup>2</sup> or equivalent to the earth conductor size, whichever is the greater.

#### 5.3.1.8.4 Battery system resistively earthed

Where the pre-assembled battery system is resistively earthed with voltages greater than DVC-A all metallic equipment enclosures associated with the BESS installation, shall be bonded together and connected to the earthing system of the electrical installation to prevent a shock hazard occurring.

The minimum size of the bonding conductor shall be 6 mm<sup>2</sup> or equivalent to the earth conductor size, whichever is the greater.

#### 5.3.1.9 Earth fault alarm

For all pre-assembled battery systems separated from earth (i.e. floating) or connected to earth via a resistor and operating at DVC-B or DVC-C, an earth fault alarm system shall be installed.

The alarm system shall include an audible signal activated in a location where an authorized person will be aware of the signal.

Earth fault detection systems, including any additional monitoring or alarm connections or devices, shall be in accordance with the manufacturer's requirements.

### 5.3.2 Energy hazard — Arc flash

There is no possibility to completely avoid arc flash hazards when working near live parts. When working with pre-assembled battery system, some parts of the pre-assembled battery system will remain energized. To limit exposure levels to arc flash hazard all maintenance and installation activities shall be according to manufacturer's instructions for the pre-assembled battery system.

### 5.3.3 Fire hazard

#### 5.3.3.1 General

Where a pre-assembled battery system (or systems) are installed in a building with a fire indication panel, a detector linked to that fire indication panel should be installed. For all other buildings a smoke alarm should be installed within the same room.

NOTE The pre-assembled battery systems location may have additional requirements in relation to fire separation between the BESS and the building to which it is attached and any adjacent building or allotment boundary in the relevant local, state or territory or national requirements, according to the building classification code.

#### 5.3.3.2 Battery alarm system

If an alarm system is provided as part of the pre-assembled battery systems, where it is an audible or visual signal the alarm shall be placed in an area where an authorized person will be aware of the signal. Where another form of alarm communication system is used to inform to the authorized person it shall be enabled and confirmed as part of commissioning. Suitable communication systems include email, SMS or similar messaging systems.

A set of operational instructions shall be provided to the system owner or nominated representative that includes the actions to be taken when the alarm is activated and to maintain any communication systems used.

### 5.3.4 Explosive gas hazard

For pre-assembled battery systems, the manufacturer's instructions on ventilation requirements shall be followed.

NOTE It is important that the installer follows the manufacturer's instructions as there are lithium ion systems that have specific ventilation requirements.

### 5.3.5 Chemical hazard

Pre-assembled battery systems that are categorized as chemical hazards in [Table 3.1](#) shall be installed in accordance with these risk reduction requirements.

Any venting requirement of the pre-assembled battery system manufacturer shall be implemented. Any containment requirements of the pre-assembled battery system shall be implemented.

### 5.3.6 Mechanical hazard

In addition to the requirements specified in [Clause 5.2.6](#), the installation of the pre-assembled battery systems shall be in accordance with the following:

- (a) For ground mounted battery system, the ground structure and type shall have structural strength to support the battery system weight; and
- (b) For wall-mounted battery system, the structural integrity of the wall shall be able to withstand the weight of the battery system.

NOTE [Table 3.1](#) shows those battery types categorized as mechanical hazards.

### 5.3.7 Toxic fume hazard

Where the pre-assembled battery system is categorized as a toxic fume hazard in [Table 3.1](#), the installation shall be in accordance with the instructions of the manufacturer.



Instructions provided by the manufacturer shall be included in the documentation provided to the system owner or nominated representative.

Where vents are required, venting shall ensure toxic fumes are vented outside of building to minimize levels below safe levels of toxicity.

Ventilation to the outside shall not be located in restricted locations for battery systems or BESS (see [Clause 5.2.2.2](#)).

NOTE 1 Some toxic fumes are heavier than air until heated, such as HF that is produced by lithium ion base battery technology. As such both inlet and outlet vents need to be considered.

NOTE 2 Refer to Safe Work Australia or WorkSafe New Zealand for information regarding workplace exposure standards for airborne contaminants.

## 5.4 System documentation, verification and commissioning

### 5.4.1 Documentation

#### 5.4.1.1 General

At the completion of the installation of a pre-assembled battery system or a battery energy storage system, documentation shall be provided in accordance with the requirements of this Clause. This documentation shall ensure that key system information is readily available to customers, inspectors, maintenance service providers and emergency service personnel.

#### 5.4.1.2 System manual

A manual, complete with the following items, shall be provided:

- (a) Battery system information including:
  - (i) Total battery storage capacity.
  - (ii) Australian/New Zealand address and contact details for the manufacturer representative (or deemed equivalent).
  - (iii) UN Number for the battery cell or battery system.
  - (iv) Commissioning date.
  - (v) System provider contact details.
- (b) A complete list of installed equipment, with model description and serial numbers.

NOTE 1 It is recommended that installers retain records of equipment installed for maintenance and records.

- (c) System performance and operation configuration: system output performance including expected operating response based on programming, expected life of battery system (including information of state of health where provided by the system), end of life system parameters and expected operational life.
- (d) Operating instructions (systems and components): a short description of the function and operation of all installed equipment.
- (e) Operational instructions for response requirements to alarms including earth fault alarms, battery management system alarms, smoke alarms, ventilation alarms and any other alarms that may be required as part of the installation.
- (f) Description and meaning of any state of health measurements, where provided.

- (g) Shutdown and isolation procedure for emergency.
- (h) Start-up procedure and verification checks.
- (i) Description of how to identify when system is not operating correctly and what to do in the case of a system failure. Details about alarm systems installed as part of the system and in addition to the system.
- (j) Maintenance procedures and schedule: maintenance procedures, a checklist for the installed equipment and schedule for these tasks including hazard mitigation requirements for maintenance tasks. Including shutdown and isolation procedure for maintenance.
- (k) Commissioning records and installation checklist: A record of the initial system settings at system installation, verification records and commissioning checklists for quality assurance.
- (l) System connection diagram: A diagram showing the electrical connections of the battery system with the PCE(s). All diagram labels shall match labels provided as per [Section 7](#).

NOTE 2 In larger installations separate schematic circuit and wiring diagrams should be provided.

- (m) Equipment manufacturer's documentation, data sheets, safety data sheets for battery systems and handbooks for all equipment supplied. Where systems have an ethernet or other form of data interface, include all information on connection requirements and system operating manuals.
- (n) Information on specific requirements to address all risks, for example, the action to take when toxic fumes are present.
- (o) List of any spare parts that have been provided (e.g. fuse replacement cartridges).
- (p) Decommissioning information for battery replacement or battery removal (including recommendations for battery recycling).

NOTE 3 An electronic version of documentation is acceptable.

## 5.4.2 Verification

### 5.4.2.1 General

The verification of a pre-assembled battery system shall be carried out in accordance with the requirements of AS/NZS 3000 for verification (inspection and testing) prior to energizing and placing the installation into service. These requirements represent minimum standards of inspection and testing to meet the minimum safety requirements for the installation. Upon completion of the verification process a report shall be provided for inclusion in the system documentation.

### 5.4.2.2 Initial verification and visual inspection

Prior to energizing and placing the installation into service, conformance of the pre-assembled battery system to AS/NZS 3000, the manufacturer's instructions and the following requirements shall be verified:

- (a) All system shutdown and start up notifications shall match system diagrams and system labelling.
- (b) Signs, labels and markings shall be installed and applied in accordance with the requirements of [Section 7](#).
- (c) Any system risk-reduction isolation devices shall operate and be accessible; such as battery system isolators for the purposes of maintenance and future work.
- (d) All terminal connections shall be tightened to the specified torque settings.
- (e) All necessary ancillary safety devices and equipment shall be installed.

### 5.4.2.3 Alterations and repairs

If there are any alterations to the pre-assembled battery system that result in the device no longer conforming to *Best Practice Guide: battery storage equipment — Electrical Safety Requirements* then the BESS shall be installed as a BESS as per [Section 6](#).

NOTE 1 To verify an altered pre-assembled battery system remains in accordance with the *Best Practice Guide: battery storage equipment — Electrical Safety Requirements* a new claim of conformance covering the alteration would need to be issued for the pre-assembled battery system.

Where there is an alteration or repair to a pre-assembled battery system installation, the electrical installation from the battery system terminal to the PCE port shall be verified to ensure that the alteration or repair is in accordance with this Standard and does not impair the safety of the existing electrical installation.

NOTE 2 Any alterations to the PCE installation need to maintain conformance to the relevant PCE installation requirements.

### 5.4.2.4 Testing

The testing of the installation shall be performed in accordance with the requirements of the manufacturer of the pre-assembled battery system and other components of the BESS and the requirements of Section 8 of AS/NZS 3000.

Battery system polarity shall be tested prior to connection to a PCE. Testing shall be carried out to ensure no inadvertent connections between floating or isolated battery systems and earth.

The following measurements should be undertaken and results recorded in the commissioning documentation:

- (a) Total battery system voltage.
- (b) Individual pre-assembled battery system voltages, if applicable.
- (c) Overall battery system voltage drop from cabling at maximum rated discharge current.

## 5.4.3 Commissioning

### 5.4.3.1 General

Any commissioning requirements of the manufacturer shall be followed.

System commissioning shall include verification that the system as a whole operates and, in particular, the pre-assembled battery system operates in both charge and discharge modes.

At installation commissioning, all d.c. connections shall be tested while the system is operating at full discharge or charge current to identify any high resistance connections.

Operational parameters that are configured at installation for the control of the battery system shall be verified (whether this is done through the PCE directly or through a data connection or host computer connection). Remote monitoring where included with the battery system should be configured so access is available to the system owner or nominated representative.

The system shutdown procedure shall be tested to ensure this results in safe shutdown of the installation.

### 5.4.3.2 Induction

An induction shall be provided to the system owner or nominated representative. This induction shall include the following:

- (a) Demonstration of the system shutdown and start up procedures including review of shutdown procedure sign.
- (b) Introduction to the system manual provided as part of the installation.
- (c) Provision of detailed information for any alarm features included in the system.
- (d) Clear information on contact details for provision of assistance.
- (e) Information pertaining to the access to specific data or hosted system information including user logins, available apps or programs.
- (f) Basic operation and design principals.
- (g) Periodic inspection and maintenance requirements.

NOTE Guidance on inspection and maintenance is provided in [Appendix H](#).

PUBLIC COMMENTING DRAFT

DRAFT

## Section 6 Battery systems and BESSs not covered by Sections 4 and 5 — Installation, commissioning and documentation

### 6.1 General requirements

This Section applies for the installation of all battery systems and BESSs that are not conforming to the *Best Practice Guide: battery storage equipment — Electrical Safety Requirements*.

Lead acid batteries shall be in accordance with AS/NZS 4029.1 or AS/NZS 4029.2, or IEC 60896 (series), or equivalent battery standard.

Nickel cadmium batteries shall be in accordance with AS 3731 series.

Secondary lithium cells and batteries shall be in accordance with IEC 62619.

Where other battery system technologies are installed, standards for the technology as they become available.

The battery system and other components that make up the BESS shall be selected such that they are compatible with types of battery technologies used. The battery system and BESS operational parameters and controls shall be configured according to manufacturer's requirements.

### 6.2 Installation of battery system

#### 6.2.1 General

Battery systems and BESSs shall be installed by competent persons.

Equipment that is mechanically damaged or damaged in any other way shall not be installed.

All the hazards associated with the relevant battery type and all associated components shall be identified. A risk assessment shall be performed prior to planning an installation of a battery system.

NOTE See [Appendix G](#) for additional information on risk assessment.

Each battery energy storage system should be installed with reference to the relevant safety data sheet (SDS), manufacturer system hazard information and the manufacturer's installation, commissioning and maintenance instructions.

#### 6.2.2 Location

##### 6.2.2.1 General

Battery systems shall be protected from mechanical damage, environmental and other external influences. Where the location chosen may expose the battery system to influences that might be reasonably expected then they should be considered as part of the installation conditions, e.g. damage caused by a vehicle where a system is being installed in a carport or garage.

Battery systems shall be installed in accordance with the manufacturer's instructions.

The battery system shall be installed in one of the following:

- (a) A dedicated enclosure: An enclosed area that is not sufficiently large to allow a person to stand and move around inside.
- (b) A dedicated room: An enclosed area that is accessible only via a door (or doors) of sufficient size to allow a person to enter and walk within this area.

The dedicated enclosure shall contain only the battery system and battery system's associated equipment or the BESS and any of its associated equipment. (See [Clause 6.2.5](#).)

The dedicated room shall contain only the battery system and battery system's associated equipment or the BESS and any of its associated equipment. (See [Clause 6.2.6](#).)

Areas for battery systems and BESSs shall be in accordance with locational restrictions for each of the identified hazards referenced in [Table 3.1](#).

The installation of battery systems or BESSs shall conform to the requirements for damp situation as defined by Section 6 of AS/NZS 3000.

Battery system and BESS locations shall be determined by outcome of the risk assessment ([Clause 6.2.1](#)).

Battery systems and BESSs shall not be installed —

- (i) in ceiling spaces;
- (ii) in wall cavities;
- (iii) on roofs not specifically deemed suitable;
- (iv) under floors of habitable rooms;
- (v) under stairways; or
- (vi) under access walkways.

In areas of domestic or residential electrical installations, the battery systems shall not be located in habitable rooms.

Suitable areas may include garages, storage rooms, dedicated battery system room and verandas.

#### 6.2.2.2 Restricted locations

A battery system or BESS shall be located to minimize the impact of any smoke generated from a fault affecting egress from the building.

A battery system or BESS shall not be installed —

- (a) in restricted locations as defined for switchboards in AS/NZS 3000;
- (b) within 600 mm of any exit;
- (c) within 600 mm any hot water unit, air conditioning unit or any other appliance ; and
- (d) or within 1200 mm below any of the items included in (b) and (c).

A battery system or BESS shall not be installed below, or within 600 mm of the vertical side of, any window and building ventilation opening.

[Figure 6.1](#) shows the restricted zones in accordance with this Clause.

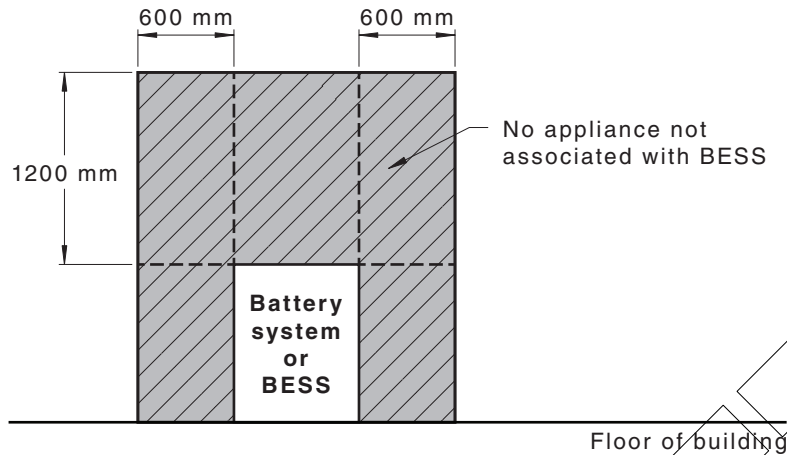

**Figure 6.1 — Restricted zones for appliances not associated with the battery systems**

A battery system or BESS installed in any corridor, hallway, lobby or the like leading to a fire exit shall ensure sufficient clearance from the battery system for safe egress and be no less than 1 m.

A battery system or BESS is considered a source of ignition therefore shall not be installed within hazardous area for gas cylinders containing heavier than air gasses and gas relief vent terminal in Section 4 of AS/NZS 3000.

### 6.2.3 Environmental requirements

#### 6.2.3.1 General

The battery system or BESS shall be designed and installed to provide protection against damage that might reasonably be expected from the presence of water, high humidity, dust, vermin or solar radiation (direct sunlight).

The battery system or BESS shall be installed in locations that avoid localized or general heat sources (such as sunlight, generators, steam pipes, space heaters and against uninsulated walls heated from direct sunlight). The flow of heated air from any appliance should be directed away from and not impact on the battery system or BESS.

The battery system or BESS shall not be installed in locations where they will be exposed to temperatures lower than the minimum or greater than the maximum temperature, as specified by the battery manufacturer.

A battery system or BESS should not be located near combustible materials.

#### 6.2.3.2 IP rating

A battery system or BESS installation shall have protection against ingress of solid foreign objects and against ingress of water. Equipment shall have an IP code rating as specified in IEC 60529 for the environment in which it is to be installed.

For battery systems, the battery terminals and other connected live parts shall have minimum protection of IP2X.

For battery systems installed outdoors, the enclosure of the battery system shall provide minimum protection of IP23 for the battery system terminals and other connected conductive parts. Higher IP rating protection may be required depending on the installation location and the battery system type.

NOTE 1 The installation of battery system and BESS enclosures indoors may have other restrictions based on their identified hazards.



NOTE 2 IP23 is the minimum and AS/NZS 3000 may require higher rating depending on location. For example, due to the environment not being fully sealed from the effects of weather, or having water or other liquid storage system in the same location, or being in the vicinity of or areas where use of a hose or washing activity of any kind may occur, or having water taps or the like.

## 6.2.4 Protection against the spread of fire

### 6.2.4.1 General

Selection and installation of battery systems shall not contribute to, or propagate a fire in accordance with AS/NZS 3000:2018 Clause 1.5.12.

NOTE This requirement is not specifically for the fire hazard of [Table 3.1](#) that is covered in [Clause 5.3.3](#).

### 6.2.4.2 Barrier to habitable rooms

For the purposes of this Clause, a surface or barrier material is considered suitably non-combustible if the material is deemed to be not combustible when tested in accordance with AS 1530.1. Materials exempt from the need to be tested to AS 1530.1 as considered to be suitably non-combustible are —

- (a) brick or masonry block;
- (b) concrete;
- (c) steel of at least 0.2 mm thickness; and
- (d) ceramic or terracotta tiles

The material shall have no vents or perforations within the zone required to be covered by the barrier. Any penetration of the barrier that has an internal free space greater than 5 mm diameter shall be sealed with a fire retardant sealant.

To protect against the spread of fire to habitable rooms, where the battery system/BESS is mounted on, or placed against, the surface of a wall or structure that has a habitable room on the other side, the wall or structure shall be a suitably non-combustible barrier. If the mounting surface itself is not made of a suitably non-combustible material, a non-combustible barrier shall be placed between the battery system/BESS and the surface of a wall or structure.

Where the battery system/BESS is located on, or mounted on the floor within 300 mm of, the wall or structure separating it from the habitable room, the barrier shall extend —

- (i) 600 mm beyond the vertical sides of the battery system/BESS;
- (ii) 1200 mm above the battery system/BESS; and
- (iii) to the extent of the bottom of the battery system/BESS.

NOTE See [Figure 6.2](#) and [Appendix E](#) for typical layout examples.

Where the top of the battery system or BESS is within 1200 mm of the ceiling or structure above the battery system or BESS, the ceiling or structure surface shall be suitably non-combustible for an area of 600 mm past the extremities of the battery system or BESS.

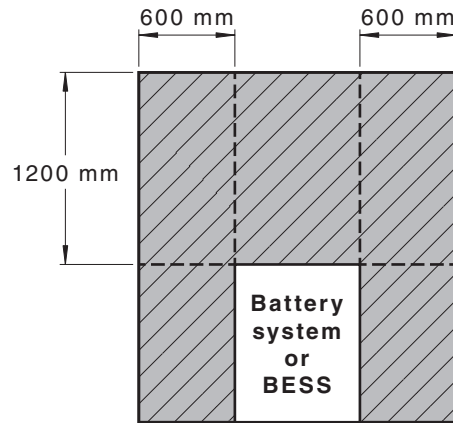

**Figure 6.2 — Barrier zones for battery systems or BESS installed on or near a habitable room facing wall**

## 6.2.5 Battery system and BESS enclosure requirements

### 6.2.5.1 General

The design of enclosures shall include means to prevent access by unauthorized persons.

It should be clean, dry, ventilated, and provide protection against detrimental environmental conditions and other external factors.

NOTE For battery system room requirements, see [Clause 6.2.6](#).

### 6.2.5.2 Battery system enclosure

#### 6.2.5.2.1 General

The battery system enclosure shall prevent unauthorized access to the battery system and the components. This is to limit exposure to any hazards as identified in [Table 3.1](#) for the battery system type. This can be achieved through the use of a suitable enclosure that requires the use of a key or tool for access.

#### 6.2.5.2.2 Design, layout and construction

The design, layout and construction of the battery system enclosure shall meet the following:

- (a) Shall be suitable for the battery type and battery system being installed;
- (b) Shall have all live parts of batteries or battery modules insulated or shrouded;
- (c) Each cell, battery or battery module terminal shall be readily available;
- (d) The installation of the cell, battery or battery modules and the associated wiring within the battery system enclosure shall meet all the requirements of [Clause 6.3.1](#);
- (e) Enclosure shall be sufficiently ventilated to allow the battery to operate within the manufacturer's nominated operational temperature range;
- (f) No metallic equipment capable of falling on the battery terminals shall be mounted in the battery system enclosure above the vertically mounted cells, batteries or battery modules;
- (g) The area inside the battery system enclosure shall allow for the following clearances:
  - (i) The space between cell/battery containers shall be at least 3 mm.

- (ii) The minimum distance between vertically mounted battery and top or roof of battery system enclosure (unless top opening) shall be half the distance from the front of the battery to the rear most terminal of the battery or 75 mm, whichever is the greater, however the vertical clearance need not exceed 200 mm between the highest point of a battery and the lowest point of the structure of the roof above for battery system enclosures with front opening access; except for vertically mounted flooded cells/batteries. For vertically mounted flooded cells/batteries there shall be a minimum clearance of 300 mm. These clearances apply unless otherwise specified by the manufacturer.
- (iii) There shall be a minimum of 25 mm clearance between a cell, battery or battery module and any wall of the enclosure unless otherwise specified by the manufacturer.

NOTE 1 It may be acceptable for battery frames to touch the wall of the battery system enclosure.

- (iv) A tiered, vertically mounted cell/battery shall meet the requirements of Items (i), (ii), and (iii). In addition, the minimum distance between the highest point of a battery and the lowest point of the structure of the tier above shall be half the distance from the front of the battery to the rearmost terminal of the battery or 75 mm, whichever is the greater, however the vertical clearance need not exceed 200 mm; except for vertically mounted flooded cells/batteries there shall be a minimum clearance of 300 mm. These clearances apply unless otherwise specified by the manufacturer.
- (v) A racked horizontally mounted cell/battery shall have a minimum 25 mm clearance between the cell/battery and the above rack.
- (vi) *Maximum height for batteries* — Batteries shall be mounted with the highest point no greater than 2.2 m above the floor level.

NOTE 2 See example layouts in [Appendix C, Figure C.2](#) and [Figure C.3](#).

The battery system enclosure's entry doors and panels shall allow unobstructed access to the battery system for installation and maintenance purposes.

The size of the battery system enclosure should allow for sufficient clearance around the battery system to provide safe handling and access for installation and maintenance. The design, layout and construction of the battery system enclosure should be insect and vermin resistant.

### 6.2.5.3 BESS enclosure

The BESS enclosure shall have at least two separate compartments: one that houses the battery system and one that houses the PCE. Associated equipment may be housed in either compartment depending on the requirements for the specific hazards referred to in [Clauses 6.3.1](#) to [6.3.7](#).

The battery system and PCE enclosures shall be accessed separately (e.g. via separate doors).

### 6.2.5.4 Installation of battery system enclosure

The minimum unimpeded access on the working side of the battery system enclosure shall be either —

- (a) 900 mm with doors open; or
- (b) 600 mm with doors open for battery systems that have —
- (i) voltage no greater than DVC-A;
- (ii) a calculated arc flash energy at the output terminals of the battery system not greater than 4.0 cal/cm<sup>2</sup>;
- (iii) maximum length of 2.2 m; and
- (iv) no more than two rows or two tiers.

For a top-opening battery system enclosure installation, no equipment shall be placed above the battery system enclosure, which could fall on the battery terminals causing a short. Non-metallic battery maintenance equipment may be located in this position. Luminaires shall not be installed directly over the top-opening battery system enclosure.

A purpose-built equipment enclosure may be installed above or alongside a purpose-built battery system enclosure.

## 6.2.6 Battery system room requirements

### 6.2.6.1 General

The battery system room shall only be used for the battery system and related BESS equipment. The battery system room shall be located so that access to a battery system is not obstructed by the structure of the building or by the fixtures and fittings within the building.

Anything not directly related to the BESS such as auxiliary equipment, rotating machinery other than exhaust fans, and other equipment shall be located outside the battery system room.

The size of the room shall allow for sufficient clearance around the battery system to provide safe handling and access for installation and maintenance.

The design, layout and construction of the battery system room shall prevent unauthorized access to the battery system and be suitable for the battery type and battery system being installed.

The room's entry doors and panels shall open in the direction of egress and allow unobstructed access to the battery system for installation and maintenance purposes.

The battery system room shall be sufficiently ventilated to allow the battery to operate within the manufacturer's nominated operational temperature range.

The battery system room design, layout and construction should be clean, dry, and ventilated, and maintain protection against detrimental environmental conditions and other external factors including being insect and vermin resistant.

NOTE Additional recommendations for battery system rooms are provided in [Clause 6.3.6.3](#).

### 6.2.6.2 Battery system room layout

The battery system room shall have enough floor area so that the battery system equipment can be accommodated and clearances and spacing for the battery system room layout are obtained.

Within the battery system room the minimum unimpeded access on the working side of the battery systems shall be either —

- (a) 900 mm as shown as shown in [Figure 6.3](#); or
- (b) 600 mm for battery systems that have —
  - (i) voltage no greater than DVC-A;
  - (ii) a calculated arc flash energy at the output terminals of the battery system not greater than 4.0 cal/cm<sup>2</sup>;
  - (iii) maximum length of 2.2 m; and
  - (iv) no more than two rows or two tiers.

In addition to the minimum unimpeded access the layout of the room containing the battery system shall meet the following requirements:

- (A) Each battery cell or module terminal shall be readily available.

- (B) No metallic equipment capable of falling on the battery terminals shall be mounted above vertically mounted cells, batteries or battery modules,
- (C) The minimum aisle width shall be 600 mm unless a greater aisle width is required for unimpeded access. A greater aisle width may also be necessary in installations requiring the use of mechanical handling equipment for battery maintenance.
- (D) The space between battery cells or modules shall be at least 3 mm.
- (E) There shall be a minimum of 25 mm clearance between a battery cells or modules and any wall or structure on a side not requiring access for maintenance. This does not prevent battery stands touching adjacent walls or structures, provided that the battery racks have a free air space for no less than 90 % of their length.
- (F) A tiered, vertically mounted battery cells or modules shall meet the requirements of Items (C), (D), and (E). In addition, this minimum distance shall be half the distance from the front of the battery to the rearmost terminal of the battery or 75 mm, whichever is the greater, however the vertical clearance need not exceed 200 mm between the highest point of a battery and the lowest point of the underside of the upper bearers of the tier above; except for vertically mounted flooded cells/batteries there shall be a minimum clearance of 300 mm. These clearances apply unless otherwise specified by the manufacturer (for examples see [Appendix C, Figures C2 and C3](#)).
- (G) A racked horizontally mounted battery cells or modules shall have a minimum 25 mm clearance between the battery cells or modules and any wall and the above rack unless specified by the manufacturer.
- (H) The battery cells or modules shall be mounted with the highest point no greater than 2.2 m above the floor level.

NOTE 1 See example layout in [Appendix C, Figure C1](#).

If a PCE or other auxiliary electrical equipment is located in a battery system room, the aisle width between any battery system or systems and any part of the enclosure, PCE equipment or auxiliary equipment shall be —

- (1) as shown in [Figure 6.3\(a\)](#), a minimum of 600 mm between opposing sets of hinged doors in the open position; and at least a total distance of 900 mm from the battery system and the PCE;
- (2) as shown in [Figure 6.3\(b\)](#), a minimum of 900 mm from any PCE enclosure with removable door in the open position; and at least a total distance of 900 mm from the battery system and the PCE; or
- (3) as shown in [Figure 6.3\(c\)](#), a minimum of 900 mm from any fixed part of the enclosure or removable access panel.

NOTE 2 See typical example in [Appendix C, Figure C.1](#).

NOTE 3 Typical battery layouts are shown in [Appendix D](#).

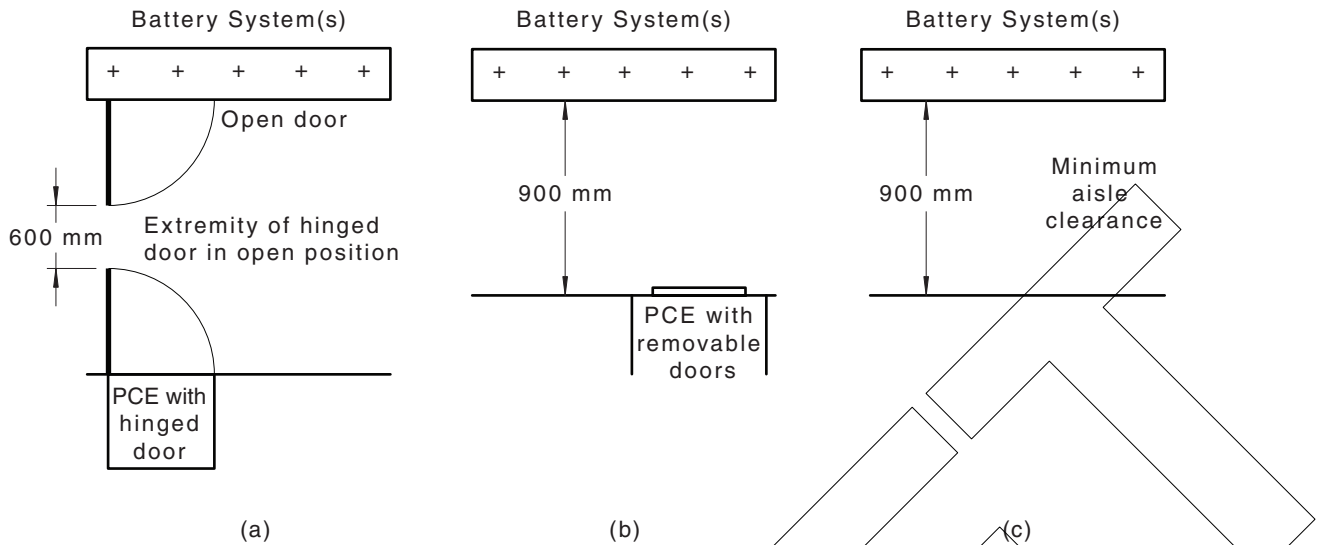

**Figure 6.3 — Minimum aisle width requirements for systems greater than DVC-A**

### 6.2.6.3 Location of luminaires

The lighting provision for battery system room shall be installed in accordance with AS/NZS 1680.1. Luminaires shall not be installed directly over a battery system or an exposed live part.

### 6.2.7 Battery cell or module stands

For battery cell or module stands the requirements of AS/NZS 1170.1, AS/NZS 1170.2, and AS 1170.4 (for Australia) and NZS 4219 (for New Zealand) shall apply.

NOTE 1 A stand is a rack, base, or shelving for holding or supporting either horizontally or vertically mounted battery cells or modules.

The following provisions apply for battery stands either within a battery system room, or part of an enclosure:

- When battery cell or module are mounted vertically, stands should be designed so that the installation per stand is limited to a depth of two rows of batteries.
- If the height of the battery cell or module is its greatest dimension, horizontal restraining bars should be installed at the front and back of the stands.

The overall height of the battery system installation shall not exceed 2.2 m.

NOTE 2 See [Appendix C](#) for typical battery stands.

### 6.2.8 Seismic (earthquake) forces

Depending on location/application, the battery system enclosure and/or battery system stand(s) may need to be designed to withstand seismic (earthquake) forces, given the combined weight of the battery, inverter or other equipment associated with the BESS and mounted in the enclosure or on the stand..

For Australia, where the battery system is installed in, or on, a building that is required to be designed for earthquake action, the earthquake action requirements for the battery system shall be in accordance with AS 1170.4.

For New Zealand, where a higher level of seismic restraint is required, the battery seismic (earthquake) restraint shall be in accordance with NZS 4219.



The requirements for seismic restraint also mean that tall BESS or battery systems comprising tall individual batteries should be installed as close as possible to the floor. Use of multi-tier battery system stands or enclosures increases the seismic restraint requirements for the upper tier(s) of batteries or battery modules, and in turn, increases the size of the vertical components and diagonal parts of the battery stand.

For battery installations the designer should seek advice from a structural engineer or similar.

## 6.3 Installation hazards

### 6.3.1 Electrical hazards

#### 6.3.1.1 General

A BESS shall not be installed if the battery system has a voltage of DVC-A and is connected to an inverter that does not have at least simple electrical separation between the battery system d.c. port and the a.c. or grid port of the inverter.

The cabling and installation requirements of the battery system shall be treated as DVC-C if a non-separated PCE other than an inverter is installed (e.g. solar charge controller) and the non-battery side of the PCE is greater than DVC-A.

#### 6.3.1.2 Overcurrent protection from battery system

##### 6.3.1.2.1 General

Overcurrent protection shall be installed in all live conductors (excluding control and monitoring circuits) in all battery systems. The overcurrent protection shall be located so as to minimize the length of the unprotected cable from the battery system.

The overcurrent protection device shall —

- (a) be of the non-polarized type;
- (b) be d.c. rated;
- (c) have a voltage rating greater than the battery system's maximum voltage under all normal and abnormal operating conditions;
- (d) meet the requirements of Section 2 of AS/NZS 3000; and
- (e) have a current rating to protect the cabling from the battery system.

NOTE 1 When connected to a system comprising multiple PCEs, the rated current of the BESS is the total sum of the currents that can be supplied from the PCEs to the battery system or the maximum rated current of the PCEs required to operate from the battery system.

Protective devices should be selected from the following:

- (i) Fuses having enclosed fuse-links (HRC fuses).
- (ii) Miniature circuit breakers (MCBs) or moulded case circuit-breakers (MCCBs).

NOTE 2 MCBs and some MCCBs have limited d.c. short-circuit current ratings and may require back up by HRC fuses.

Where parallel battery systems are installed, each battery system shall include a separate overcurrent protective device. This is to prevent discharge from one battery system into a parallel battery system if a fault occurs in one battery system.



### 6.3.1.2.2 Requirements for circuit breakers

In addition to the requirements specified in [Clause 6.3.1.2.1](#), circuit breakers used for overcurrent protection shall be in accordance with either AS/NZS 60898.2 or IEC 60947-2.

Circuit breakers for indoor use shall be mounted in enclosures that have a minimum rating of IP23.

Circuit breakers for outdoor use shall be suitably rated for ambient temperature of 40 °C and should be mounted in enclosures that have a minimum rating of IP56.

The selection and connection of circuit breakers shall take into account the applied voltage when the system is earthed and unearthed.

NOTE It may be necessary to take into account whether earth is connected to the positive or the negative pole of the battery system, or whether earth is connected to a centre tap or similar.

### 6.3.1.2.3 Requirements for HRC fuses and holders

In addition to the requirements specified in [Clause 6.3.1.2.1](#), HRC fuses and holders used for overcurrent protection for battery systems shall —

- (a) be in accordance with IEC 60269-1 and IEC 60269-3;
- (b) be mounted in a purpose built fuse holder;
- (c) not be a type able to be rewired;
- (d) require a tool to access live parts or terminals; and
- (e) be mounted in a fuse holder providing the minimum degree of protection of IP4X.

Fuse and fuse holder that are not rated for load breaking shall be installed to provide restricted access and labelled as per [Clause 7.13.3](#).

### 6.3.1.2.4 Battery systems that include overcurrent protection

Battery systems that include overcurrent protection either in the BMS or integral to the battery system the protection devices may meet the requirements for overcurrent protection of the output cables from the battery system where —

- (a) the battery system includes overcurrent protection that is a readily available circuit-breaker or HRC fuse;
- (b) the battery system manufacturer's instructions permits the use of the overcurrent protection of the BMS to meet the overcurrent protection of the battery system output cables; and
- (c) the output cables have a current carrying capacity greater than the rating of the protection device.

### 6.3.1.2.5 Location of overcurrent protection devices

Battery systems that are categorized as explosive gas hazards have restrictions regarding where overcurrent protection devices are able to be located (see location requirements of [Clauses 6.3.4.3, 6.3.4.4](#) and [6.3.4.5](#)).

When a battery system overcurrent protection device or devices are not included within the battery system in accordance with [Clause 6.3.1.2.4](#), the overcurrent protection devices shall be —

- (a) installed as close as practical to the output terminals of the battery system but no greater than 2 m; and
- (b) readily available.

For many battery system technologies, there is no overcurrent protection provided if a short/fault occurs on the battery system side of the overcurrent protection device/s. Therefore there is no overcurrent protection for the interconnecting connectors, cables or links that interconnect the battery or battery modules in series within a battery system. Interconnecting connectors, cables or links should be protected by inter-string overcurrent protection internal to the battery system.

### 6.3.1.2.6 Battery systems not requiring a battery management system

The output cables or busbars of a battery system shall be protected against overcurrent according to [Clause 6.3.1.2.1](#).

Where there are parallel battery systems and each of the battery systems' output cables or busbars connect individually to a PCE (see [Figure 6.4](#)), all output cables or busbars connected to each of the battery systems shall be protected against overcurrent.

Where there are parallel battery systems and the output cables or busbars of each battery system are connected at a common point as shown in [Figures 6.4](#), overcurrent protection devices shall be installed in —

- each battery system cable or busbar as required by [Clause 6.3.1.2.1](#); and
- each cable going to the PCE if the current-carrying capacity of each of the cables going to the PCE is less than the sum of the overcurrent protection devices protecting the individual battery systems.

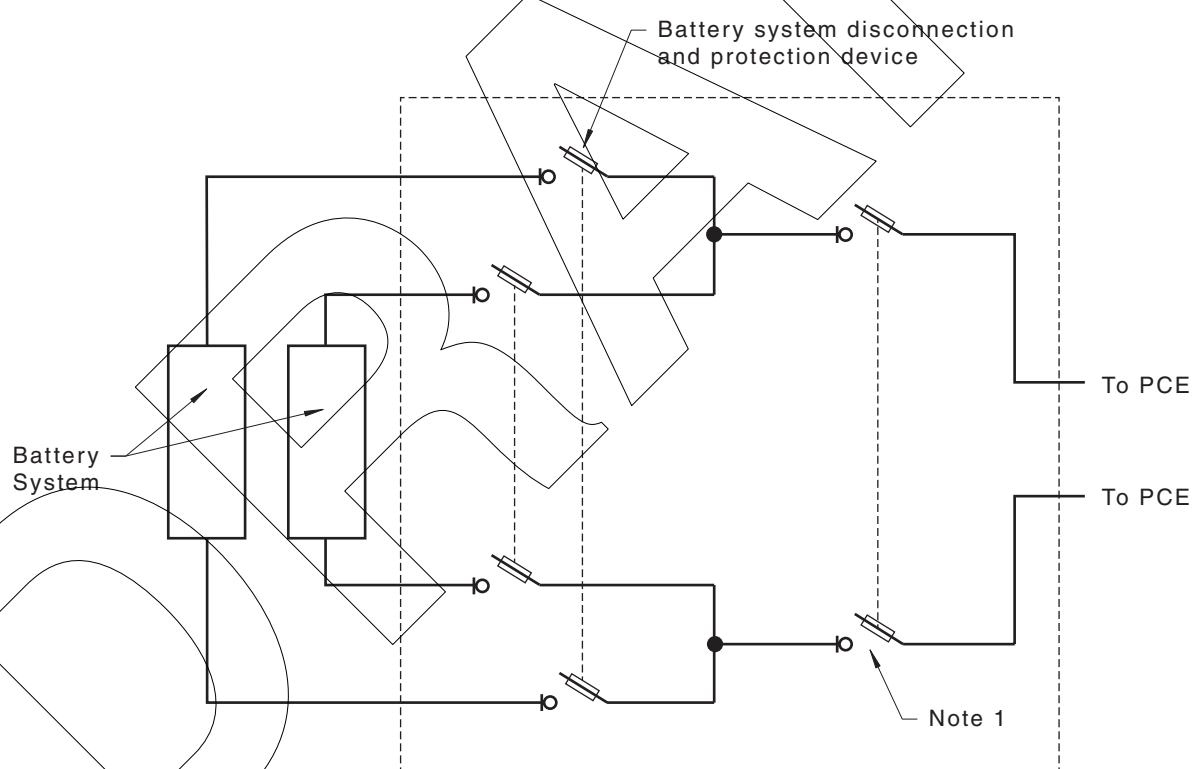

NOTE 1 Overcurrent protection is required for live conductors when conductor current-carrying capacity is less than the sum of all individual battery system overcurrent protection devices.

NOTE 2 Switch fuses are shown as overcurrent protection devices.

**Figure 6.4 — Typical overcurrent protection requirements for parallel battery systems connected at a common point**

### 6.3.1.3 Isolation of the battery system

#### 6.3.1.3.1 General

All battery systems shall be capable of being electrically isolated from all other equipment within the BESS. Isolation devices shall be capable of being secured in the open position. The isolation device shall operate simultaneously in all live conductors. The isolation device shall be capable of load breaking.

The overcurrent protection device, may also perform the function of the isolation device provided it is rated for isolation function.

Where a battery system includes an internal non-serviceable battery management system, the point of isolation shall be after the output terminals of the battery system.

#### 6.3.1.3.2 Battery systems that include internal isolation

The battery system may include an internal isolation device operating in all live conductors. Where an internal isolation device provides the same functions as for an adjacent isolation device, no additional adjacent isolation device is required.

If the battery system includes a BMS that meets the overcurrent protection requirements but does not provide the same function as for an isolation device, an adjacent isolation device shall be installed that isolates the output of the battery system.

#### 6.3.1.3.3 Parallel battery systems

For battery energy storage systems where there are two or more battery systems connected in parallel, each battery system shall have an isolating switch in all live conductors. This isolation device is to facilitate the isolation of one battery system for maintenance and allow the continuous operation of the remaining system.

#### 6.3.1.3.4 Requirements for battery system: switch-disconnector

Switch disconnectors used as a load breaking disconnection device shall —

- (a) conform to AS 60947.3;
- (b) be of the non-polarized type;
- (c) be d.c. rated;
- (d) have a voltage rating greater than the battery system's maximum voltage under all operating conditions;
- (e) be rated to withstand the maximum short circuit current;
- (f) have a current rating greater than the maximum rated d.c. current for the BESS;
- (g) be rated to interrupt for full load;
- (h) meet the requirements of Section 2 of AS/NZS 3000 for isolating device selection;
- (i) be rated for independent manual operation;
- (j) have a minimum pollution degree 3 classification;
- (k) be able to be secured in the open position, and only secured when the main contacts are in the open position;
- (l) conform to requirements for isolation, including marking requirements for an isolation device; and
- (m) have a utilization category of at least DC21B.

Switch-disconnectors for indoor use shall be mounted in enclosures that have a minimum rating of IP23.

Switch-disconnectors for outdoor use shall be mounted in enclosures that have a minimum rating of IP56 when tested under conditions of Clauses D.8.3.13.4, D.8.13.3.5, D.8.3.13.6, D.8.13.3.7 and D.8.13.3.8 of AS 60947.3:2017. Switch-disconnectors for outdoor use shall be suitably rated for ambient temperature of 40 °C.

### 6.3.1.3.5 Battery system: interconnection isolating requirements

If the battery system includes individual battery or battery modules that are serviceable and has either —

- (a) a voltage exceeding DVC-A; or
- (b) is installed in a domestic building and has an arc flash incident energy level above 4 cal/cm<sup>2</sup>;

The battery system installation shall be fitted with isolating switches, connectors, cables or links to separate the battery system into sections where each section has a voltage below DVC-A or sections that will reduce the arc flash incident energy levels to the levels in [Clause 6.3.2](#) for the installation location and tasks required.

Suitably identified interconnecting connectors, cables or links (e.g. with insulation of a different colour to other interconnecting devices) may be used for this purpose.

The interconnecting connectors, cables or links shall only be removed when the battery system's isolation device has been secured in the open position and before any work is carried out.

The current-carrying capacity of the battery interconnecting connectors, cables or links shall be rated to —

- (i) the maximum current rating of the battery system; and
- (ii) the short circuit current and the duration from the battery system.

### 6.3.1.3.6 Location of isolation devices

Battery systems that are categorized as explosive gas hazards have restrictions regarding where isolation devices are able to be located (see location requirements of [Clauses 6.3.4.3](#), [6.3.4.4](#) and [6.3.4.5](#)).

Where an external isolation device is required, the isolation device shall be —

- (a) installed as close as practical to the output terminals of the battery system but no greater than 2 m; and
- (b) readily available.

NOTE In battery system rooms, the treatment of the access to isolation devices for emergency services personnel may mean that the devices are located near the entrance door.

## 6.3.1.4 Screening from touch of live parts

### 6.3.1.4.1 General

The complete battery system shall be screened to prevent accidental short-circuiting of the battery terminals and connections.

All live battery, battery module and battery system terminals and interconnecting connectors, cables or links shall have;

- (a) screening from touch that is at least IP2X; and
- (b) mechanical protection for location.

Any cover shall be able to be removed for inspection and maintenance of the terminals and interconnections.

NOTE Covers may be made from insulating conduit or ducting or be covers supplied by the battery system manufacturer.

The battery system screening may include probe or testing apertures for maintenance or fault-finding purposes. Apertures provided for probe or testing access shall meet at least IP2X to ensure the safe access and operation of maintenance and test equipment.

#### 6.3.1.4.2 Battery systems operating at DVC-B level and DVC-C level

Where the battery systems operates at DVC-B or DVC-C level all shrouding or insulation of live parts should be structured such that removal of this protection is only able to expose sections with voltage difference of no greater than DVC-A.

#### 6.3.1.4.3 Battery system terminals and outgoing busbars

If outgoing busbars are connected to the battery system or battery modules terminals, the outgoing busbars shall —

- (a) be insulated from the battery system or battery module terminals to a height of 2.5 m or the battery system room ceiling height, whichever is the lower; and
- (b) be clearly identified and segregated from other supply circuits.

The battery system terminals and busbar connections shall have their polarity clearly identified and be shrouded or be protected by insulating barriers, having an IP rating of at least IP2X.

#### 6.3.1.4.4 Inter tier and inter row connections

The battery and battery module interconnecting cables, connectors or links between inter-row and inter-tier terminals shall be either shrouded or protected by insulating barriers, having an IP rating of at least IP2X.

#### 6.3.1.5 Battery system wiring to PCE

##### 6.3.1.5.1 General

Wiring between the battery system and PCE should be installed in a way to minimize effects of inductive loops.

The cable from the battery system to the overcurrent protection device shall have no other devices connected other than monitoring and control circuits.

##### 6.3.1.5.2 Type of cable

Battery system cables shall be in accordance with —

- (a) AS/NZS 5000.2 (450/750 V insulation) for battery systems with a maximum operating voltage less than 450 V d.c.;
- (b) AS/NZS 5000.1 (0.6/1 kV insulation) for battery systems with a maximum operating voltage less than 600 V d.c.; or
- (c) IEC 62930 for battery systems with a maximum operating voltage less than 1500 V d.c.

NOTE IEC 62930 is for photovoltaic systems, however, it covers cables sizes up to 400 mm<sup>2</sup> and 1500 V rating and is suitable for battery systems.

Wiring between the battery system and the PCE shall meet the requirements of AS/NZS 3000 for selection and installation of wiring systems.

The cable from the battery system to the PCE shall be —

- (i) double insulated if the voltage exceeds DVC-A; and
- (ii) double insulated for DVC-A battery system connected to a non-separated PCE (e.g. solar charge controller) and the non-battery side of the PCE is greater than DVC-A.

The cable between the battery system, the overcurrent protection device and the PCE should be double insulated for all battery systems operating at DVC-A.

#### 6.3.1.5.3 Mechanical protection

For battery systems installed in a room, the battery system cables from the battery system terminal to point of connection to the overcurrent protection device shall not exceed 2 m in length without protection by medium duty conduit or equivalent protection.

All cables that exit the battery system enclosure or battery system room to the point of connection to the battery system overcurrent protection device shall be mechanically protected by at least medium duty conduit or equivalent protection up to the overcurrent protection device.

For battery systems operating at DVC-B or DVC-C, the cable between the overcurrent protection device and the PCE shall have mechanical protection

NOTE Refer to AS/NZS 3000:2018, Clause H4.

#### 6.3.1.5.4 Voltage drop

The voltage drop between the battery system and the PCE should be no more than 2 % based on the rated d.c. battery port current of the PCE and shall be no more than 5 % under any operating condition.

NOTE Voltage drop impacts the settings for charge and discharge control of the battery system and to ensure safe charging and discharging of the battery system needs to be taken into account in setpoints.

#### 6.3.1.5.5 Current-carrying capacity

The current-carrying capacity of the battery system's cable to the overcurrent protection device shall be rated to the maximum current rating of the battery system. The current carrying capacity of the battery system cables to the PCE shall be greater than the rating of the overcurrent protection devices installed (see [Clause 6.3.1.2](#)).

The minimum cable sizes for battery system wiring, shall be based upon the current carrying capacity of the relevant flexible cables as specified in —

- (a) AS/NZS 3008.1 series; or
- (b) as specified by the manufacturer of the cable.

NOTE AS/NZS 3008.1 series applies to a.c. cables, but for the purposes of this Standard, the current rating tables and calculations are relevant also for d.c.

#### 6.3.1.5.6 Parallel battery systems

For a BESS consisting of two or more battery systems connected in parallel, the output cable or busbar from each battery system to a point where the parallel battery systems connect (e.g. PCE or junction box), shall have equal resistance. This can be achieved by cables being of equal length, equal cross-sectional area and conductor materials.



**Exception — This requirement does not apply where there is a BMS or similar device that provides managed voltage and current charge/discharge control to each separate system.**

#### 6.3.1.5.7 Protection from overcurrent from PCE

Overcurrent protection shall be installed on the battery system's d.c. port of the PCE if —

- (a) the PCE's charging current or load current under fault conditions is greater than the current-carrying capacity of the conductor between the PCE and battery system; and
- (b) the length of cable between the PCE and the battery system overcurrent protection device is greater than 3 m.

#### 6.3.1.6 Isolation of PCE from battery system

##### 6.3.1.6.1 General

PCEs shall be capable of being isolated from the battery system for the purpose of maintenance, repair and fault-finding. Where a switch-disconnector is used for this purpose it shall conform to [Clause 6.3.1.3](#).

Where a circuit breaker is used for this purpose it shall conform to [Clause 6.3.1.2.2](#) and be rated for isolation function.

##### 6.3.1.6.2 BESS with single PCE

If the PCE is not adjacent to the battery system(s), a separate isolation device shall be installed adjacent to the PCE to isolate the PCE.

##### 6.3.1.6.3 BESS with multiple PCEs

When a BESS includes multiple PCEs (e.g. a solar charge controller and an inverter; or multiple inverters), a separate isolation device shall be installed adjacent to each PCE.

##### 6.3.1.6.4 PCE with internal isolation device

The PCE may include an internal isolation device operating in all live conductors. Where an internal isolation device provides the same functions as for an adjacent isolation device and the internal isolation device meet one of the following requirements:

- (a) An isolation device that is mechanically interlocked with a replaceable module of the PCE, and allows the module to be removed from the section containing the isolation device without risk of electrical hazards.
- (b) All live parts are inside enclosures or behind barriers that provide a degree of protection of at least IPXXB or IP2X (i.e. all live parts are screened from touch).

Where an internal isolation device meets these requirements no additional adjacent isolation device is required.

#### 6.3.1.7 Segregation of circuits

In addition to the segregation requirements of Section 3 of AS/NZS 3000, segregation shall be provided between d.c. and a.c. circuits within enclosures such that connections and pathways are physically segregated from each other by an insulating barrier(s). DC wiring shall not be installed or pass through a.c. switchboards or enclosures unless segregated by means of an insulating barrier, such as conduit or trunking.

Where devices such as switches for circuits requiring segregation are mounted on a common mounting rail in an enclosure, this rail shall not be metallic or conductive unless the entire enclosure is metallic.



Segregation insulation barriers between the d.c. and a.c. circuits shall be equivalent to double insulation for the highest voltage level present and compatible with the installation environment.

The different types of circuits shall be clearly identified (e.g. by labels and, where possible, by use of different coloured cables).

Outside of enclosures, a separation of 50 mm or a segregation insulation barrier between a.c. and d.c. circuits shall be provided.

Segregation insulation barriers between the d.c. and a.c. circuits shall be to the level required for the installation environment and not less than IP4X.

### 6.3.1.8 Earthing of the battery systems

#### 6.3.1.8.1 General

The four categories of earthing arrangements for battery systems connected to inverters are listed as follows and specific requirements for each system are listed in the referenced clauses:

- (a) Floating/separated, i.e. not earthed and not referenced to earth (see [Clause 6.3.1.8.2](#)).
- (b) Direct earthed (see [Clause 6.3.1.8.3](#)).
- (c) Resistive earthed (see [Clause 6.3.1.8.5](#)).
- (d) Battery system connected to a non-separated inverter, i.e. referenced to the a.c. grid and therefore to earth by the inverter's internal connections (see [Clause 6.3.1.8.7](#)).

Where the electrical installation earthing is not rated to carry the fault current of the battery system, the battery system earth cable shall be connected to the earth electrode.

The PCE and battery manufacturer's instructions should be followed to determine the best earthing arrangement.

Battery systems connected to inverters that do not have separation between the d.c. port and the a.c. port or grid port, shall not be earthed.

The battery isolator shall have at least one pole for each live conductor including the conductor that is earthed. For example, if the system comprises a centre tapped earth then a 3 pole switch-disconnector is required for breaking simultaneously the two battery system output cables and the centre tapped earth.

#### 6.3.1.8.2 Floating/separated

Floating battery system connected to a separated inverter is where the battery system is not earthed and is not referenced to earth (see [Figure 6.5](#)).

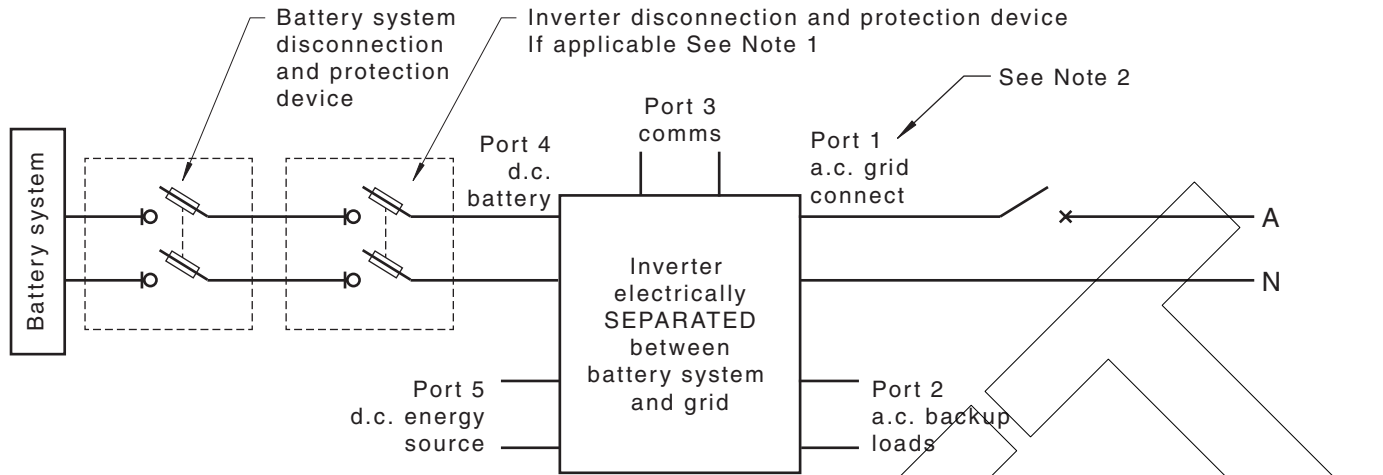

NOTE 1 PCE disconnection device required if the battery system disconnection device is not adjacent (see [Clause 6.3.1.6](#)).

NOTE 2 Port 1 is the a.c. port shown for a grid-connected system. This port could also be the input from a generator.

NOTE 3 In this case the battery is separated from the mains and from earth and is said to be “floating”.

**Figure 6.5 — BESS installation diagram: floating battery system connected to a separated inverter**

As the battery system is separated from earth (i.e. floating) and the PCE is electrically separated from the output application circuit there is no additional earthing requirements except for earth fault monitoring (see [Clause 6.3.1.10](#)).

**6.3.1.8.3 Earth connection requirement — Direct earthed**

A direct earthed battery system is a battery system, with a direct earth connection, connected to an inverter providing separation from the grid (see [Figure 6.6](#)).

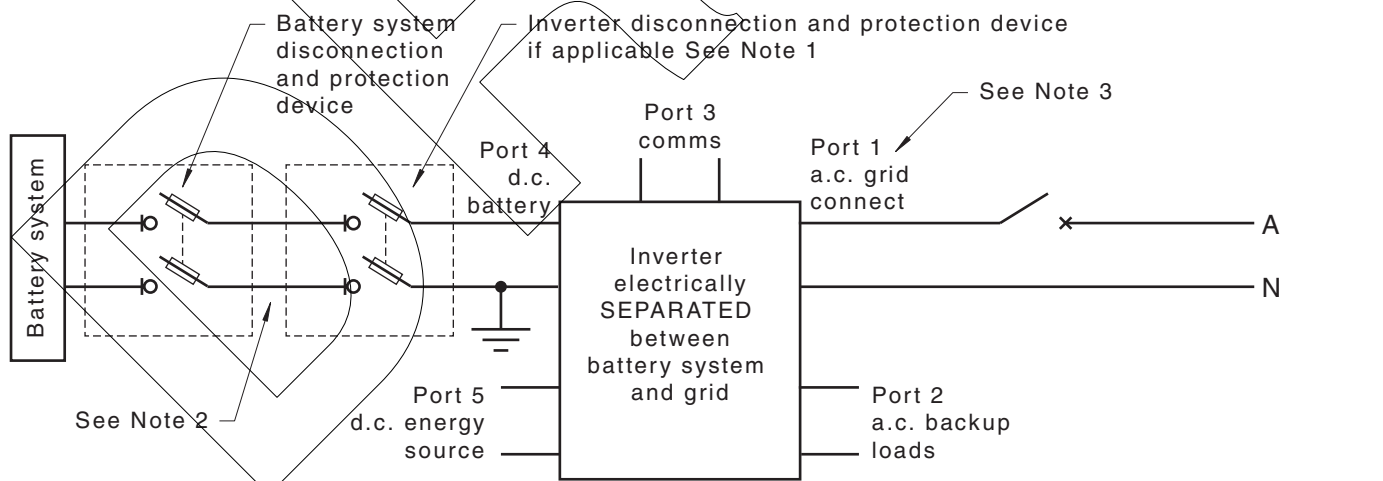

NOTE 1 PCE disconnection device required if the battery system is not adjacent (see [Clause 6.3.1.6](#)).

NOTE 2 Earth fault protection (See [Clause 6.3.1.10](#)) required for battery systems greater than DVC-A. For BESS at DVC-A, AS/NZS 5033:2014 methodology has been applied.

PUBLIC COMMENTING DRAFT

NOTE 3 Port 1 is the a.c. port shown for a grid-connected system. This port could also be the input from a generator.

**Figure 6.6 — BESS installation diagram: battery connected to an inverter providing separation from the grid with a direct earth connection**

For directly earthed battery system, one conductor of the battery system shall be connected to the installation earthing system (see [Figures 6.9 to 6.13](#)). The battery system earthing conductor shall be rated to withstand the prospective earth fault current of the battery system for a time at least equal to the operating time of the associated overcurrent protective device (see [Clause 6.3.1.8.7](#)).

NOTE Installation earthing system needs to be checked as per [Clause 6.3.1.8.1](#).

#### 6.3.1.8.4 Earth connection requirements — Resistive earthed

A resistive earthed battery system is a battery system, with a resistor inserted in series with the earth connection, connected to an inverter providing separation from the grid (see [Figure 6.7](#)).

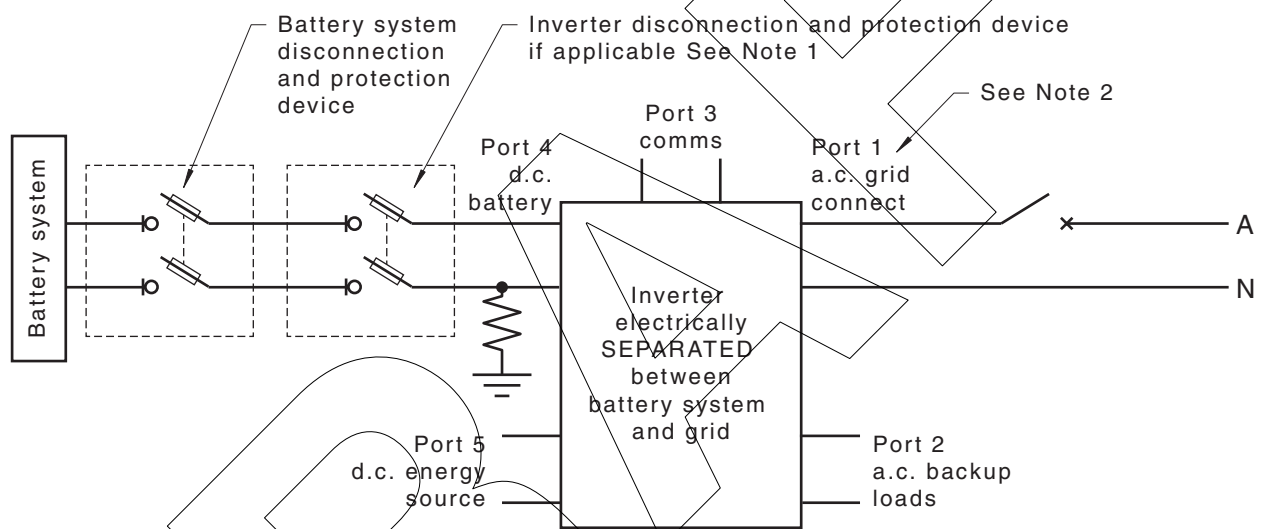

NOTE 1 PCE disconnection device required if the battery system is not adjacent (see [Clause 6.3.1.6](#)).

NOTE 2 Port 1 is the a.c. port shown for a grid-connected system. This port could also be the input from a generator.

**Figure 6.7 — BESS installation diagram: battery connected to an inverter providing separation from the grid with resistive earth connection**

For resistively earthed battery system, one conductor of the battery system shall be connected to the installation earthing system via a resistor (see [Figures 6.8 to 6.13](#)). The battery system earthing conductor shall be rated to withstand the prospective earth fault current of the battery system continuously.

NOTE In a resistively earthed system the prospective earth fault current is significantly reduced by the use of the resistor and may not trip the overcurrent protection.

#### 6.3.1.8.5 Battery system connected to a non-separated inverter

For battery systems connected to a non-separated inverter, no conductor of the battery system shall be connected to the installation earthing system. This is a floating battery system connected to a non-separated inverter and no conductor of the battery system is earthed and is not referenced to earth (see [Figure 6.8](#)).

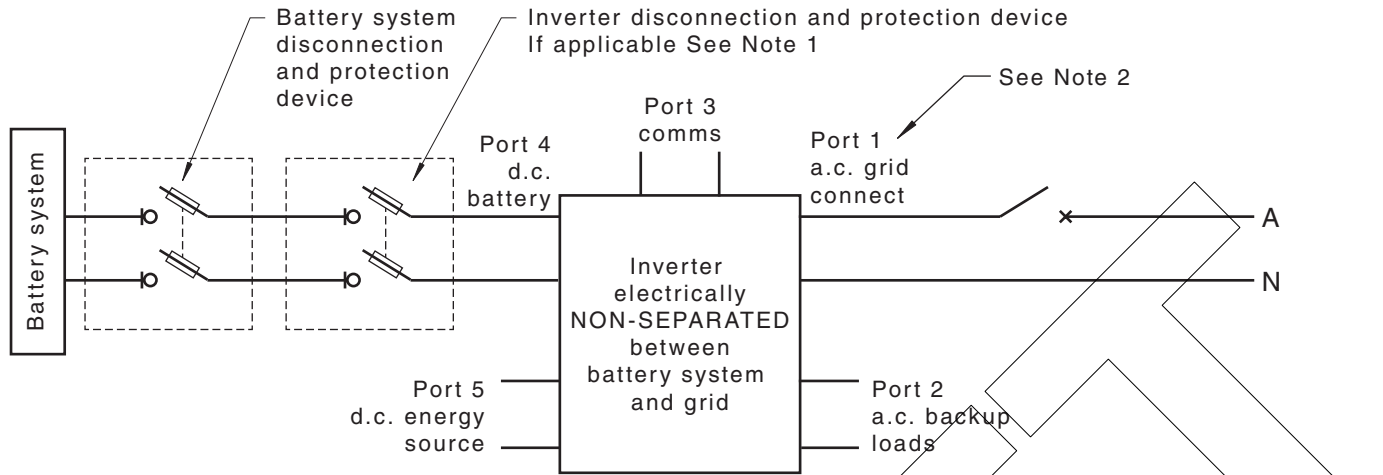

NOTE 1 PCE disconnection device required if the battery system disconnection device is not adjacent (see Clause 6.3.1.6).

NOTE 2 Port 1 is the a.c. port shown for a grid-connected system. This port could also be the input from a generator.

NOTE 3 In this case the battery is NOT separated from the mains as there is a connection internally in the inverter between the grid connect port and the battery system.

**Figure 6.8 — BESS installation diagram: battery system connected to a non-separated inverter**

**6.3.1.8.6 Battery system earth location**

The earth connection shall be on the PCE side of the battery system isolator (see Figure 6.9). Isolating the battery system from the PCE and earth connection provides an isolated battery system that is floating, minimizing the electrical hazard during maintenance.

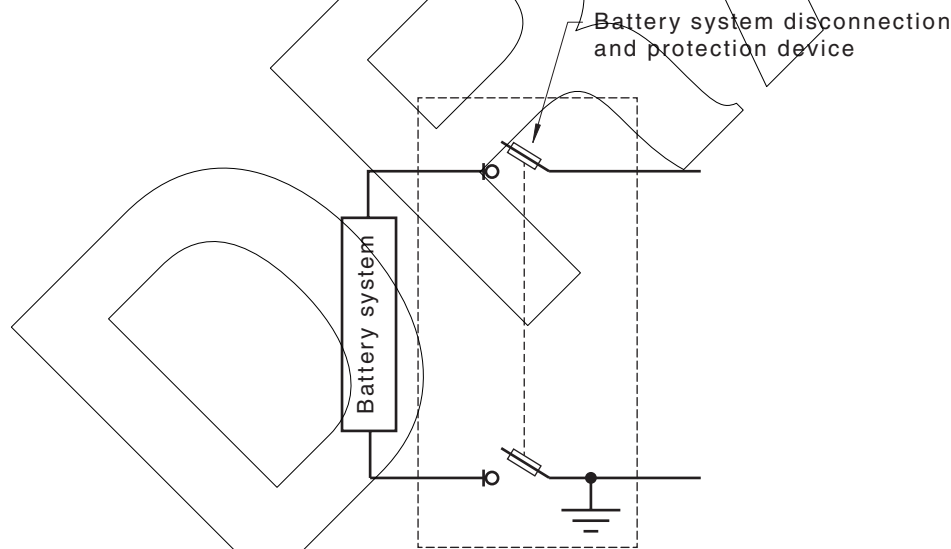

NOTE Where resistive earthing is in use a resistor is inserted in series with the earth connection.

**Figure 6.9 — Location of earth connection on single battery system**

When the BESS comprises multiple parallel battery systems that require earthing, there shall be an earth connection on the PCE side of the battery system isolators as shown in Figures 6.10 to 6.14.

PUBLIC COMMENTING DRAFT

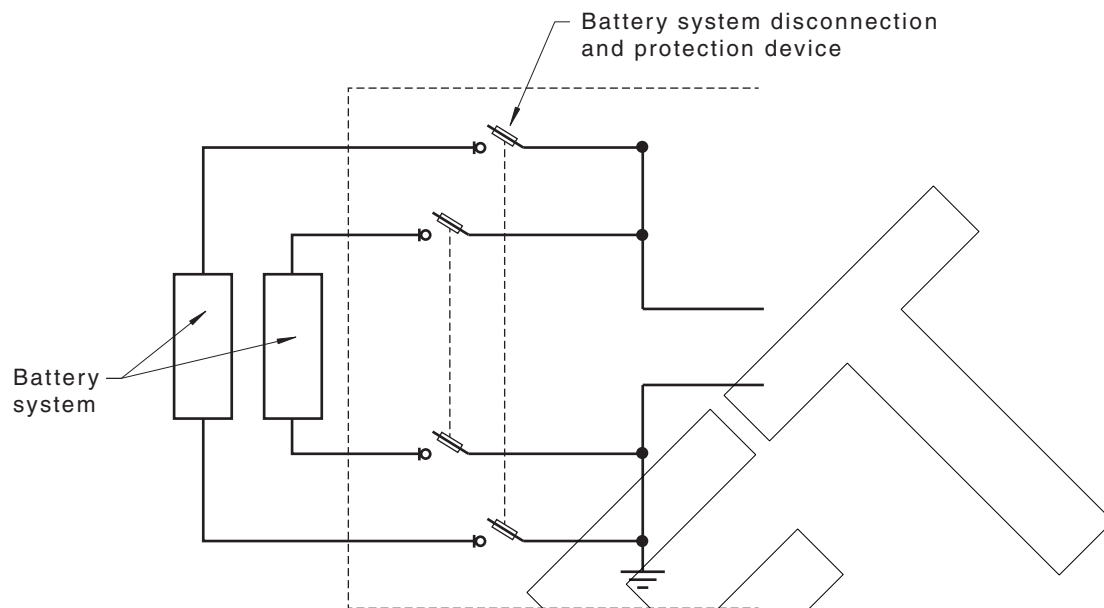

NOTE Where resistive earthing is in use a resistor is inserted in series with the earth connection.

**Figure 6.10 — Location of earth connection on parallel battery systems**

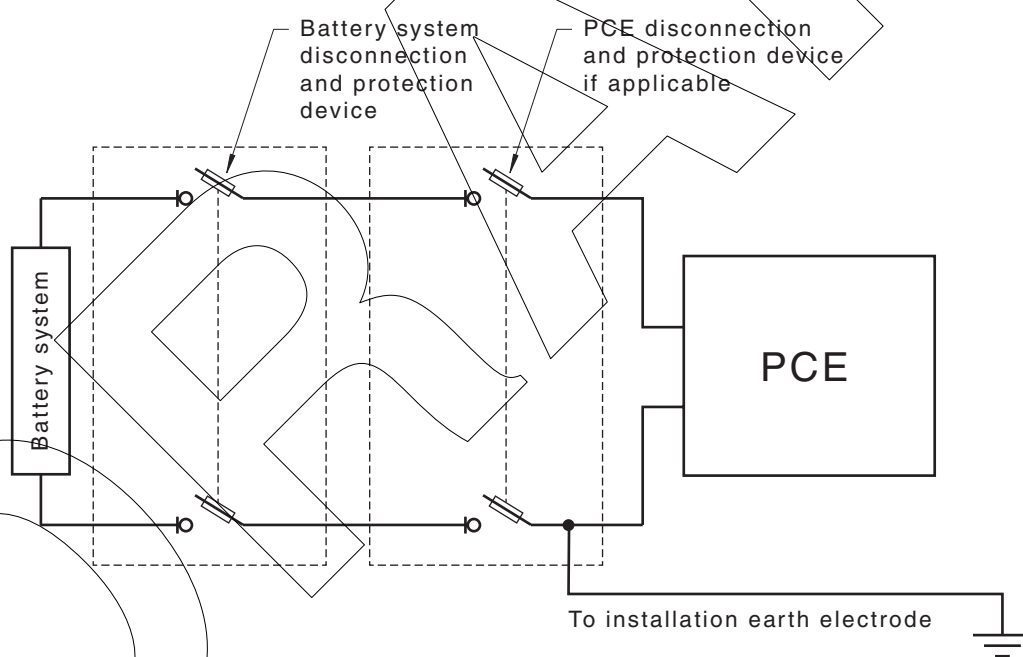

NOTE Where resistive earthing is in use a resistor is inserted in series with the earth connection.

**Figure 6.11 — Battery system earth conductor connected to installation earthing system**

If there are multiple parallel battery systems that are earthed, each system shall have a conductor that is connected to the earthing system via one earth conductor (see [Figure 6.12](#)).

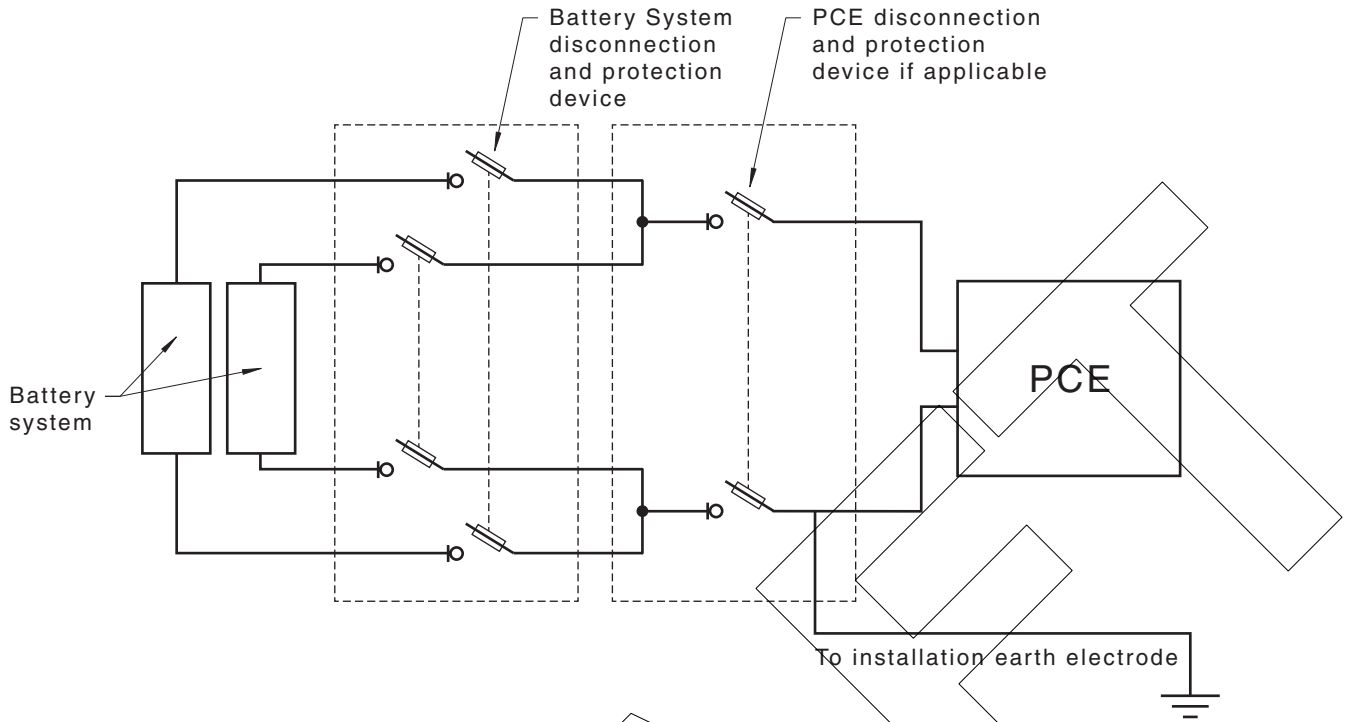

NOTE Where resistive earthing is in use a resistor is inserted in series with the earth connection.

**Figure 6.12 — Multiple battery system earth conductors connected to installation earthing system**

If there are multiple parallel BESSs and each BESS is earthed on the d.c. supply side, each BESS shall have a conductor connected to the earthing system (see [Figure 6.13](#)).

PUBLIC COMMENTING DRAFT

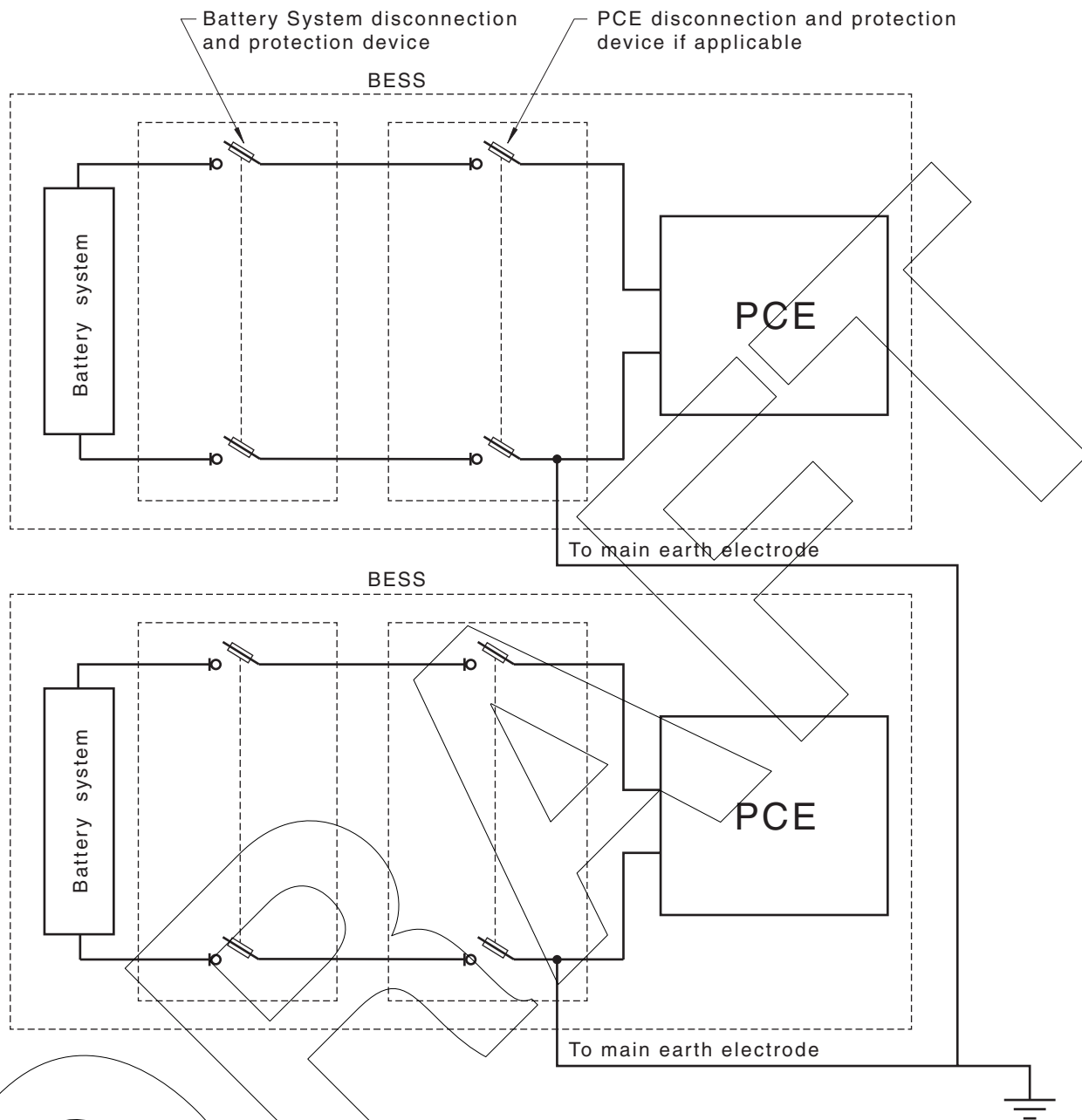

NOTE Where resistive earthing is in use a resistor is inserted in series with the earth connection.

**Figure 6.13 — Multiple BESS earthing conductors connected to installation earthing systems**

If there are multiple parallel PCEs and one pre-assembled battery system, the earth conductor between the battery system isolator and all PCE isolators (see [Figure 6.14](#)).



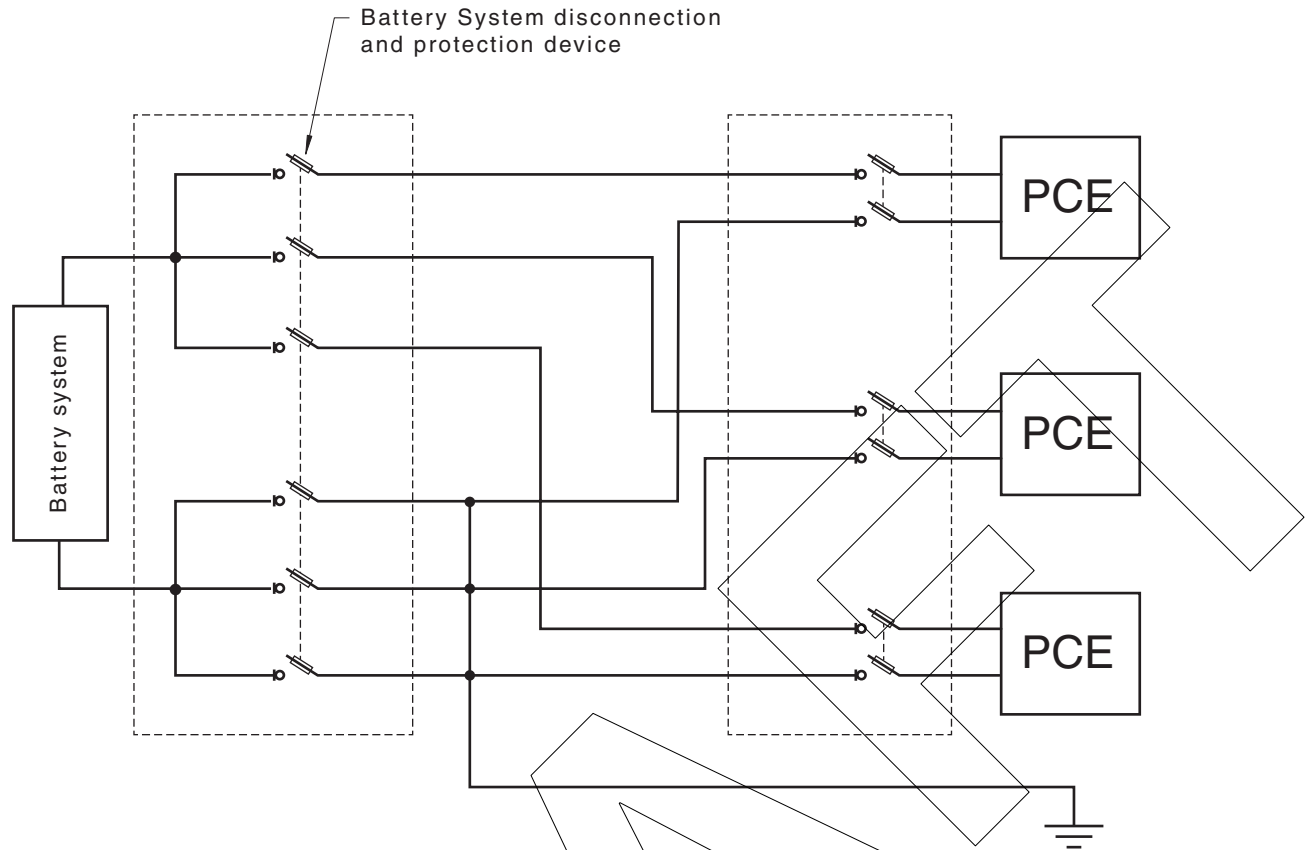

NOTE Where resistive earthing is in use a resistor is inserted in series with the earth.

**Figure 6.14 — Single battery system and multiple PCE earthing conductors connected to installation earthing system**

#### 6.3.1.8.7 Size of earth cable

The earth cable in an earthed battery system shall be sized according to AS/NZS 3000:2018 Clause 5.3.3.1.2. This relates to the cable cross-sectional area being required to be determined either —

- from AS/NZS 3000:2018 Table 5.1 in relation to the cross-sectional area of the largest active conductor supplying the portion of the electrical installation to be protected; or
- by calculation in accordance with AS/NZS 3000:2018 Clause 5.3.3.1.3.

When the BESS is earthed at the battery system or PCE, the earth cable shall be calculated according to Item (b) to carry the maximum earth fault current for a time at least equal to the operating time of the associated overcurrent protective device.

NOTE In the event of unintentional contact of an earth conductor to unearthed (live) parts, the fault current can be significant.

If the BESS comprises multiple parallel battery systems and if there is only one battery system cable connected to the PCE the “nominal size of earth conductor” shall be sized to carry —

- the maximum earth fault current for a time at least equal to the operating time of the associated overcurrent protective device for that cable (see [Figure 6.12](#)); or
- the sum of the maximum earth fault currents for a time at least equal to the operating time of the associated overcurrent protective device for the individual battery cable (refer to AS/NZS 3000, Section 5) or the sum of the individual battery system battery cables (see [Figure 6.10](#)).

NOTE If there is no single fuse protecting the single cable then Item (ii) applies.

### 6.3.1.9 Earthing system

#### 6.3.1.9.1 General

If the battery system enclosure or battery system stand is conductive and the battery system is operating at voltages greater than DVC-A, the enclosure or stand shall be earthed.

#### 6.3.1.9.2 Battery system not earthed — bonding

For an installation comprising a single BESS with voltages greater than DVC-A, all metallic equipment enclosures associated with the BESS installation, shall be bonded together and connected to the earthing system of the electrical installation to prevent a shock hazard occurring.

The minimum size of the bonding conductor shall be 6 mm<sup>2</sup>.

#### 6.3.1.9.3 Battery system is directly earthed

Where the battery system is directly earthed, with voltages greater than DVC-A all metallic equipment enclosures associated with the BESS installation, shall be bonded together and connected to the earthing system of the electrical installation to prevent a shock hazard occurring.

The minimum size of the bonding conductor shall be 6 mm<sup>2</sup> or equivalent to the earth size, whichever is the greater.

#### 6.3.1.9.4 Battery system resistively earthed

Where the battery system is resistively earthed, with voltages greater than DVC-A all metallic equipment enclosures associated with the BESS installation, shall be bonded together and connected to the earthing system of the electrical installation to prevent a shock hazard occurring.

The minimum size of the bonding conductor shall be 6 mm<sup>2</sup> or equivalent to the earth size, whichever is the greater.

#### 6.3.1.10 Earth fault protection — Monitoring alarm

For all battery systems separated from earth (i.e. floating) or is connected to earth via a resistor and is operating at DVC-B or DVC-C, an earth fault alarm system shall be installed.

The alarm system shall include an audible signal activated in a location where operational staff or system owners are informed of the signal.

Earth fault protection including any additional monitoring or alarm connections or devices shall be in accordance with the manufacturer's requirements.

### 6.3.2 Energy hazard

#### 6.3.2.1 Arc flash

There is no possibility to completely avoid arc flash hazards when working near live parts. When working with battery systems, some parts of the battery system will remain energized. Work procedures shall take into account the need to limit exposure levels to arc flash hazard for installation and maintenance tasks required for the battery system. The work procedures and installation design should facilitate that work be done with de-energized systems or systems being able to have exposure levels significantly reduced through isolation procedures.

Personal protection equipment (PPE) against arc flash is rated in accordance with the available energy from the flash, in calories per square centimetre (cal/cm<sup>2</sup>). When working on battery systems, the

correct level of PPE based on the potential arc flash energy for the battery system shall be selected and worn within the arc flash boundary.

See [Clause 3.2.4](#) for methods for calculating arc flash incident energy and arc flash boundaries.

NOTE 1 [Appendix F](#) provides examples and tables for arc flash for various battery system voltages.

NOTE 2 See [Table 3.3](#) for further information on PPE ratings.

### 6.3.2.2 Arc flash risk assessment

[Table 6.1](#) provides the estimated consequence level based on the calculated arc flash energy. Prior to installing a battery system, the arc flash energy shall be calculated based on a short-circuit occurring at the output terminals of the battery system.

**Table 6.1 — Consequence levels based on arc flash energy**

Consequence level	Arc flash incident energy level, cal/cm <sup>2</sup>
Insignificant	≥ 0.0, < 1.2
Minor	≥ 1.2, < 4.0
Moderate	≥ 4.0, < 8.0
Major	≥ 8.0, < 40
Catastrophic	≥ 40

### 6.3.2.3 Battery system installed within a residential or domestic electrical installation

For battery systems installed within residential or domestic electrical installation the arc flash value shall be less than 40 cal/cm<sup>2</sup>.

Where the battery system has a calculated arc flash value greater than 4.0 cal/cm<sup>2</sup>, the battery system shall be installed —

- in a dedicated battery system room or enclosure not attached to the building containing habitable rooms; or
- at least to the requirements of fire hazard level 1.

A battery system installed externally and not connected to a building with habitable rooms should have arc flash energy less than 8 cal/cm<sup>2</sup>. If arc flash of less than 8 cal/cm<sup>2</sup> cannot be achieved, then the battery system configuration shall ensure that the battery system can be isolated into blocks where each block has an arc flash value of no more than 4 cal/cm<sup>2</sup>.

Where the battery system has a calculated arc flash value greater than 4.0 cal/cm<sup>2</sup> the battery system shall not be installed in any of the following locations:

- Within a building containing habitable rooms.
- Externally where the room or enclosure is against an external wall of the building containing habitable rooms.

NOTE See [Appendix F](#) for example arc flash calculations.

Where the battery system has a calculated arc flash value greater than 4.0 cal/cm<sup>2</sup> then inter-string overcurrent protection devices should be installed to reduce the arc flash energy below 4.0 cal/cm<sup>2</sup>.

These interconnecting cables could be protected if there is an inter-string overcurrent protection device located in one of the battery or battery module interconnecting cables or links as shown in [Figure 6.15](#). This shows an inter-string overcurrent protection device in series in the middle of the battery system. Installing an inter-string overcurrent protection device within the battery system as

shown in [Figure 6.5](#) may reduce the calculated arc flash incident energy for work being undertaken on the battery system side of the battery system's protective device if the arcing time of the overcurrent protection device is known and less than 2 s. (See [Clause 3.2.4.2.3](#).)

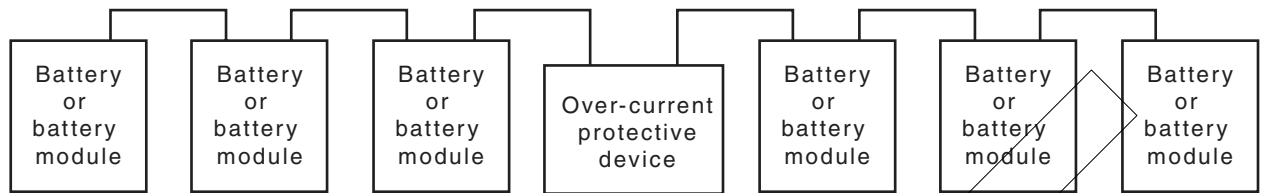

**Figure 6.15 — Overcurrent protection device in series in middle of battery string or battery modules**

#### 6.3.2.4 Battery system installed in other electrical installation

Battery systems installed in a building shall have arc flash energy less than 40 cal/cm<sup>2</sup>.

Battery system with a calculated arc flash energy greater than 4.0 cal/cm<sup>2</sup> shall be installed in a dedicated battery system room or within a dedicated enclosure located outside of the building.

Battery system installed that have an arc-flash energy greater than or equal to 8.0 cal/cm<sup>2</sup> should be able to isolate the battery system into blocks of less than 8.0 cal/cm<sup>2</sup> to limit the arc flash hazard exposure for authorized people working on the system.

#### 6.3.2.5 Arc flash boundary

The arc flash boundary shall be the distance at which incident energy equals 1.2 cal/cm<sup>2</sup>.

The arc flash boundary can be determined using the following equations:

$$AFB = \sqrt{(0.0083 \times V_{\text{sys}} \times I_{\text{arc}} \times T_{\text{arc}} \times MF)} \quad 6.3.2(1)$$

or

$$AFB = \sqrt{((0.01 \times V_{\text{sys}} \times I_{\text{arc}} \times T_{\text{arc}} \times MF) / 1.2)} \quad 6.3.2(2)$$

where

AFB = arc flash boundary, in centimetres

$V_{\text{sys}}$  = system voltage, in volts

$I_{\text{arc}}$  = arcing current, in amperes

$T_{\text{arc}}$  = arcing time, in seconds (see [Clause 3.2.4.2.3](#))

MF = multiplying factor (see [Clause 3.2.4.3](#))

while

$$I_{\text{arc}} = 0.5 \times I_{\text{bf}}$$

where

$I_{\text{bf}}$  = battery system prospective fault current in amps

An arc flash boundary nominal distance of 45 cm has been used for the calculation of incident energy. This is based on a “nominal” working distance (see [Clause 3.2.4.2.2](#)) and risk of injury to the body and face of persons working on equipment. It is necessary to ensure that measures are taken, for example, when working on battery cells, where a person’s hands and arms may be within the arc flash boundary, where likely incident energy levels are far higher. As a result it is required that all tools used be insulated, and hand protection should also be used. The PPE equipment as required from [Clause 3.2.4.4](#), shall be worn whenever a person intends to work in an area located within the determined arc flash boundary.

### 6.3.3 Fire hazard

#### 6.3.3.1 General

In addition to the enclosure and room requirements specified in [Clauses 6.2.3, 6.2.5 and 6.2.6](#), all battery types that are categorized as fire hazards in [Table 3.1](#) shall be installed in accordance with the fire hazard level requirements specified in this [Clause \(6.3.3\)](#).

Where a battery system is installed in a building with a fire indication panel, a detector linked to that fire indication panel should be installed. For all other buildings a smoke alarm should be installed within the same room.

NOTE The pre-assembled battery systems location may have additional requirements in relation to fire separation between the BESS and the building to which it is attached and any adjacent building or allotment boundary in the relevant local, state or territory or national requirements, according to the building classification code.

Since many battery systems require ventilation of the normal gases types, the ventilation from the battery system shall exhaust to outside of the building only (see [Figure 6.16](#)).

#### 6.3.3.2 Fire hazard level 1 installation requirements

##### 6.3.3.2.1 Domestic and residential electrical installation

The installation requirements for battery system types shown as fire hazard level 1 in [Table 3.1](#), installed in a domestic or residential electrical installation are as follows:

- (a) Shall be in a detached non-habitable building or another purpose built structure within a battery system room or battery system enclosure;
- (b) Where the battery system is in a battery system room or enclosure installed externally and adjoining a building, precautions shall be taken to minimize the spread of fire by the selection of appropriate materials and installation methods.
- (c) When the battery system room or enclosure is adjoining a building any penetration into the building that has an internal free space greater than 5 mm diameter shall be sealed with a fire retardant sealant.
- (d) Shall not be installed inside a building containing habitable rooms associated with the electrical installation.
- (e) Shall not be installed within 1 m of any access/egress area.
- (f) Shall not be installed under any part of a building containing habitable rooms associated with the electrical installation.

### 6.3.3.2.2 Non-domestic and non-residential electrical installation

The installation requirements for battery system types shown as fire hazard level 1 on [Table 3.1](#), installed in a non-domestic and non-residential electrical installation are as follows

- (a) Shall be housed in a room with precautions taken to minimize the spread of fire by the selection of appropriate materials and installation methods.
- (b) Shall not be installed within 1 m of any access/egress area.

### 6.3.3.3 Fire hazard level 2 installation requirements

#### 6.3.3.3.1 Domestic and residential electrical installation

The installation requirements for battery system types shown as fire hazard level 2 in [Table 3.1](#), installed in a domestic or residential electrical installation are as follows:

- (a) Where the battery system is in a battery system room or enclosure installed in a building, precautions shall be taken to minimize the spread of fire by the selection of appropriate materials and installation methods.
- (b) Where the battery system is in a battery system room or enclosure installed externally and adjoining a building, precautions shall be taken to minimize the spread of fire by the selection of appropriate materials and installation methods.
- (c) Any penetration of the enclosure or room housing the battery system into a room that has an internal free space greater than 5 mm diameter shall be sealed with a fire retardant sealant.
- (d) Shall not be installed within 1 m of any access/egress area.
- (e) Shall not be installed under any part of a residential or domestic building containing habitable rooms.

#### 6.3.3.3.2 Non-domestic and non-residential electrical installation

The installation requirements for battery system types shown as fire hazard level 2 on [Table 3.1](#), installed in a non-domestic and non-residential electrical installation are as follows

- (a) Shall be housed in a room with precautions taken to minimize the spread of fire by the selection of appropriate materials and installation methods.
- (b) Shall not be installed within 1 m of any access/egress area.

#### 6.3.3.4 Battery management system (BMS)

Battery systems that are categorized as fire hazards due to fault conditions identified in [Clauses 6.3.3.6 to 6.3.3.10](#) shall be installed with a BMS that is compatible with the particular type of battery system. The BMS shall monitor all the potential and controllable fault conditions that result in a fire if they occur. The BMS shall either take direct action as specified in [Clauses 6.3.3.6 to 6.3.3.10](#) and/or provide an actionable alarm.

Where more than one battery chemistry is provided to constitute a battery system, each of the battery chemistries or technologies used shall include a suitable BMS.

The BMS should —

- (a) monitor the battery system's temperature and voltage; and
- (b) maintain the charging and discharging of the battery system between the manufacturer's specified voltage and temperature windows.



### 6.3.3.5 Battery alarm system

Where an alarm system is required or provided as part of the battery systems, and it is an audible or visual signal, the alarm shall be placed in an area where an authorized person will be aware of the signal. Where another form of alarm communication system is used to inform to the authorized person it shall be enabled and confirmed as part of commissioning. Suitable communication systems include email, SMS or similar messaging systems.

A set of operational instructions shall be provided to the system owner or nominated representative that includes the actions to be taken when the alarm is activated and to maintain any communication systems used.

### 6.3.3.6 Excess temperature

The battery system shall not be exposed to temperatures greater than the maximum temperature specified by the product's manufacturer. For those battery types shown as fire hazard level 1 in [Table 3.1](#), where high temperature can result in a fire, the BMS shall —

- (a) monitor the temperature of at least every thermally coupled block of cells; and
- (b) act to shutdown the battery or battery module if the temperature exceeds the maximum value as specified by the manufacturer.

### 6.3.3.7 Minimum temperature

The battery system shall not be exposed to temperatures lower than the minimum temperature specified by the product's manufacturer. For those battery types shown as fire hazard level 1 for which low battery temperature can result in a fire, the BMS shall —

- (a) monitor the temperature of the battery or battery module; and
- (b) act to shutdown the battery or battery module if the temperature falls below the minimum value as specified by the manufacturer.

### 6.3.3.8 Overcurrent

The maximum available charge current being applied to the battery system shall not be greater than the maximum allowable charge current as specified by the manufacturer.

The battery system shall have a BMS that monitors the charge current and either —

- (a) disconnects the charging source when the battery exceeds the maximum current as specified by the manufacturer; or
- (b) limits the charging current to no greater than the maximum value allowed.

### 6.3.3.9 Over voltage

The maximum allowable voltage of the battery system shall not be exceeded. When maximum voltage is exceeded an over voltage alarm shall be activated.

Where the battery system is categorized as fire hazard level 1, the BMS shall act to shutdown the battery when the voltage of any particular cell, battery or module exceeds the maximum value as specified by the manufacturer.

Where the battery system is categorized as fire hazard level 2, it shall have a BMS that monitors the battery system voltage and either —

- (a) disconnects the charging source when the battery system exceeds the maximum voltage as specified by the manufacturer is reached; or



- (b) reduces the charging current so that the voltage does not rise above the maximum allowable voltage.

#### 6.3.3.10 Over discharge

Where the battery system is categorized as fire hazard level 1 and a discharge past a specified point can result in a fire, the BMS shall —

- (a) electrically disconnect the battery or battery module from the system if the battery system's voltage or battery system's state of charge drops below the minimum voltage or state of charge specified by the battery manufacturer.
- (b) shutdown the battery, battery module or battery system and not be able to recharge.

Where the battery system is categorized as fire hazard level 2, the BESS shall include a PCE which cannot draw power from the battery system when the battery system's voltage or state of charge is less than the limits specified by the battery manufacturer.

Where the battery system is not shut down due to over-discharged batteries, an alarm shall be activated.

#### 6.3.3.11 Protection against mechanical damage from external forces

Where the battery system is categorized as fire hazard level 1, and is susceptible to fire due to puncturing of an individual battery cell, battery or battery module, the system shall be installed with mechanical protection to withstand crushing, impacts, vibration and shock abuse.

### 6.3.4 Explosive gas hazard

#### 6.3.4.1 General

Battery systems that are categorized as explosive gas hazards in [Table 3.1](#), shall be installed in accordance with [Clauses 6.3.4.2 to 6.3.4.5](#).

Ventilation of the battery systems shall be in accordance with the applicable requirements of [Clause 6.3.4.2](#) and be either natural or mechanical ventilation type. The rate of ventilation shall be determined based on the battery system type.

Ventilation is used to ensure that all explosive gases are exhausted to the outside of the building, depending on the amount of explosive gas generated. Ventilation to the outside of the building shall not be located in restricted locations for battery systems or BESS (see [Clause 6.2.2.2](#)).

#### 6.3.4.2 Ventilation

##### 6.3.4.2.1 General

All battery system enclosures and battery system rooms containing battery types that are categorized as explosive gas hazard shall be ventilated.

All battery types categorized as explosive gas hazards generate hydrogen and oxygen gases during charging. The major release of hydrogen gas occurs after a cell has achieved 95 % of charge, or during any boost charging or overcharging of the battery.

##### 6.3.4.2.2 Sealed valve-regulated lead acid cells

All battery system enclosures and battery system rooms containing sealed valve-regulated (sealed) type cells shall be ventilated.

The manufacturer's specified charging regime for sealed valve-regulated batteries shall be followed. Under conditions of overcharge or electrical abuse, significant amounts of hydrogen gas can be generated and emitted from sealed valve-regulated cells. Further, the thermal and charge management

of sealed valve-regulated cells is more critical than for vented cells, and generally the sealed valve-regulated cell will be irreversibly damaged when subjected to sustained electrical abuse.

NOTE The chemistry of a sealed valve-regulated battery operates on an internal oxygen-recombination cycle which is arranged to suppress hydrogen gas evolution. Under normal operating conditions, hydrogen gas evolution and venting in sealed valve-regulated cells is much lower than the hydrogen gas released by conventional vented (flooded) cells. The hydrogen suppression efficiency in valve-regulated batteries varies with cell technology, but typically exceeds 80 % for gel cells and 90 % for absorbent glass mat cells.

#### 6.3.4.2.3 Rate of ventilation (lead acid)

The average hydrogen concentration by volume in a battery system enclosure or battery system room shall be maintained below 2 %.

The minimum exhaust ventilation rate required to maintain hydrogen concentration below 2 % shall be calculated by the following equation:

$$q_v = 0.006nI$$

6.3.5(1)

where

- $q_v$  = minimum exhaust ventilation rate, in litres per second
- $n$  = number of 2 V battery cells
- $I$  = charging rate, in amperes

If there are multiple parallel battery systems in the battery system enclosure or battery system room the total exhaust ventilation rate is the sum of the rates of ventilation of all the battery cells, modules or battery systems.

#### 6.3.4.2.4 Charging rate

Where the battery type is a flooded lead acid battery the charging rate ( $I$ ) used in the ventilation equation shall be the maximum combined output rating of the charger(s) or the rating of the battery system overcurrent protection device, whichever is the lesser.

Where the battery type is a sealed valve-regulated lead acid battery the charging rate ( $I$ ) used in the ventilation equation is determined for two conditions, as follows:

- (a) *Condition I* — If the PCE(s) acting as a charger does not have an automatic overvoltage cut-off, the charging current is the maximum output rating of the charger or the rating of the overcurrent protection device of the charger, whichever is the lesser
- (b) *Condition II* — If the PCE(s) acting as a charger has an automatic overvoltage cut-off set at the battery manufacturer's specified level, the charging rate is 0.5 A per 100 A.h. at the 3 h rate of discharge of battery capacity.

NOTE 1 These charging rates are based on a float voltage of 2.27 V per cell and have been selected to provide a safe level of ventilation for all types of battery construction.

Where the battery type is nickel cadmium battery, the charging rate ( $I$ ) used in the ventilation equation is 1.5 A per 100 A.h. at the 3 h rate of discharge of battery capacity.

NOTE 2 These charging rates are based on a float voltage of 1.45 V per cell and has been selected to provide a safe level of ventilation for all types of battery construction.

#### 6.3.4.2.5 Method of ventilation — Natural ventilation

Where possible, natural ventilation should be used for battery system rooms and enclosures because of the fault potential and spark potential of mechanical ventilation.

For natural ventilation, the minimum size of inlet and outlet apertures is determined from the following equation:

$$A = 100q_v \quad 6.3.5(2)$$

where

$A$  = the minimum area of the apertures, in square centimetres

$q_v$  = the minimum exhaust ventilation rate, in litres per second

The equation assumes that a minimum air velocity of 0.1 m/s will flow through the apertures.

#### 6.3.4.2.6 Method of ventilation — Mechanical ventilation

Where mechanical ventilation is used, the minimum flow rate is determined by the ventilation equation specified in [Clause 6.3.4.2.2](#).

Mechanical ventilation shall only be used on the air inlet to prevent fan damage from the battery acid fumes and remove electrical equipment from what is potentially an explosive gas zone.

An air flow sensor shall also be installed to activate an alarm and discontinue charging in the event of a fan failure.

#### 6.3.4.2.7 Arrangement of ventilation

The following requirements apply to the arrangement and layout of the ventilation system:

- (a) Battery system rooms and enclosures shall be provided with ventilation by means of holes, grilles or vents so that air sweeps across the battery.
- (b) The inlet and outlet vents shall be on laterally opposite sides of the enclosure except when —
  - (i) a sloping internal ceiling of the enclosure is used to direct explosive gases to the vent;
  - (ii) Lengths of vents are at least 75 % of the enclosure face and centrally located; and
  - (iii) No more than two rows of batteries cells or modules.

NOTE 1 See [Appendix D, Figure D.3](#) and [Figure D.4](#).

The following recommendations apply to the arrangement and layout of the ventilation system:

- (A) Ventilation outlets should be at the highest level in the battery system enclosure and/or battery system room.
- (B) Ventilation inlets should be at a low level in the battery system enclosures. Inlets should be no higher than the tops of the individual batteries or battery modules, and, where required, fitted with a screen to prevent the entry of vermin.
- (C) To avoid stratification of the airflow, ventilation inlets and outlets should consist of —
  - (1) a number of holes spaced evenly along the side of the room or enclosure; or
  - (2) a slot running along the side of the room or enclosure.

NOTE 2 [Appendix D](#) provides examples of battery system enclosures.

#### 6.3.4.2.8 Other battery system chemistries

For battery system chemistry types other than lead acid or nickel cadmium, the manufacturer's instructions on ventilation requirements shall be followed.

NOTE It is important that the installer follows the manufacturer's instructions as there are lithium ion systems that have specific ventilation requirements.

#### 6.3.4.3 Additional requirements for battery system enclosures

In addition to the enclosure requirements specified in [Clause 6.2.5](#), battery system enclosures shall meet the following requirements for battery systems categorized as explosive gas hazards in [Table 3.1](#):

- (a) The design of the enclosure shall prevent the formation of gas pockets.
- (b) The enclosure shall meet ventilation requirements for the particular battery types specified by [Clauses 6.3.5.2](#).
- (c) No equipment, which could cause a spark or arc, shall be installed above the battery or battery modules inside the enclosure.
- (d) The enclosure's doors, access panels, cable entry glands between the battery system and any other part of the BESS shall seal in a manner that ensures air flows from inlet to outlet vents across the battery system and not by other unsealed apertures.
- (e) Battery system overcurrent protection devices and battery system isolation devices shall be mounted outside the battery system enclosure, but as close as practicable to the battery system enclosure (to minimize cable length).
- (f) Socket outlets shall not be installed within the enclosure.

Where a purpose-built equipment enclosure is installed above a purpose-built battery system enclosure the following shall be met:

- (i) A gas proof barrier shall be between the battery system enclosure and the equipment enclosure.
- (ii) The ventilation paths for the battery system enclosure and the equipment enclosure shall be specifically designed to eliminate the possibility of air having been exhausted from the battery system enclosure entering the air inlets on the equipment enclosure.

NOTE 1 See [Appendix D Figure D.3](#).

The purpose built equipment enclosure should be ventilated using natural ventilation (i.e. without the use of an electrically powered fan).

NOTE 2 Typical combined battery and inverter or electronic equipment enclosures are shown in [Appendix D](#).

#### 6.3.4.4 Additional requirements for installation of battery system or BESS enclosures

Where battery types that are categorized as explosive gas hazards according to [Table 3.1](#) are installed, the installation of the battery system or BESS enclosure shall, in addition to [Clause 6.2.5](#), be in accordance with the following:

- (a) For enclosures installed within a room, the battery system enclosure outlets vents shall be vented outside, unless the enclosure is mounted in a dedicated battery system room, and the size of the inlet and outlet ventilations shall be determined in accordance with the formulas in [Clause 6.3.5.2](#).
- (b) No equipment shall be placed above the battery system enclosure except where the access doors and vents are not top opening, there is a gas proof horizontal barrier in place between the battery system enclosure and the equipment and the outlet vents are vented to the outside of the building.
- (c) Luminaires shall not be installed within 200 mm of any battery system enclosure.

NOTE See [Appendix D Figure D.1](#).

#### 6.3.4.5 Additional requirements for battery system rooms

In addition to the room requirements specified in [Clause 6.2.6](#), battery system rooms installed in a dedicated area shall meet the following requirements for battery systems categorized as explosive gas hazards according to [Table 3.1](#):

- (a) The design of the room shall prevent the formation of gas pockets.
- (b) The size of the inlet and outlet ventilations shall be determined in accordance with the formulas in [Clause 6.3.5.2](#).
- (c) The room outlet vents shall be ventilated to outside the building.
- (d) Battery system overcurrent protection devices, isolating switches and all socket-outlets that are mounted in the battery system room shall be mounted a minimum of 100 mm below the battery terminals or a minimum of 600 mm horizontally from the batteries.
- (e) A minimum horizontal separation of 600 mm shall be provided between the battery system and all other equipment within a battery system room from 100 mm below battery terminals, except where there is a solid separation barrier.
- (f) Luminaires shall not be installed within 200 mm of any battery system or within the path of the ventilation flow from the battery system.

NOTE See [Appendix D](#).

Battery system overcurrent protection devices and battery system isolation devices should be mounted outside the battery system room. The cable length between the overcurrent protection and battery terminals should be minimized (see [Clause 6.3.1.2.5](#)).

### 6.3.5 Chemical hazard

#### 6.3.5.1 General

Where the battery system is categorized as a chemical hazard in [Table 3.1](#), it shall be installed in accordance with risk reduction requirements of [Clauses 6.3.4.2](#) to [6.3.4.5](#).

#### 6.3.5.2 Puncturing

Battery and battery modules within a battery system shall be mechanically protected to minimize the risk of being punctured. This can be achieved via the use of a suitable battery system enclosure or dedicated battery system room.

The installation of a battery system in a dedicated battery system room should be carried out such that the potential for damage to the battery or battery module case is minimized.

#### 6.3.5.3 Containment

Battery systems that contain liquid chemical hazards shall include a containment system (bundling or spill trays) within the battery system enclosure and/or battery system room.

The bundling or spill trays shall —

- (a) be made of materials suitable for the containment of the battery system's liquid chemicals;
- (b) be sized to contain a minimum amount of spill or discharged chemical equal to either —
  - (i) one battery or battery cell, if lead acid batteries are installed, whichever is greater by volume; or

- (ii) one battery or battery module, if other battery types are installed, whichever is greater by volume; and
- (c) retain battery chemicals within the battery system enclosure or battery system room for the ease of collection and for the prevention of the spreading of the battery liquid chemical to adjacent areas.

Valve regulated lead acid (VRLA) batteries do not require spill trays or bunding to contain spills.

Safety signs (see [Section 7](#)) shall be installed informing the actions that shall be undertaken in the event of a chemical spillage or leak.

**6.3.5.4 Additional requirements for enclosures and rooms**

In addition to the requirements specified for the enclosure in [Clauses 6.2.5](#), battery system enclosures and BESS enclosures for battery systems categorized as chemical hazards shall be resistant to the effects of any chemical spillage from the particular battery type installed. This may be achieved by either the selection of materials used or by chemical resistant coatings.

In addition to the requirements specified for the room in [Clause 6.2.6](#), battery system rooms for battery systems categorized as chemical hazards, should have building material within 1 m of a battery system in a room that is resistant to the effects of the battery system’s chemical either by a selection of the materials used or by chemical resistant coatings.

If the fumes from the chemicals are corrosive —

- (a) no electrical equipment shall be located above the enclosure or battery system;
- (b) the fumes shall be vented outside the building; and
- (c) no equipment shall be installed in the shaded areas shown in [Figures 6.16](#) and [6.17](#).

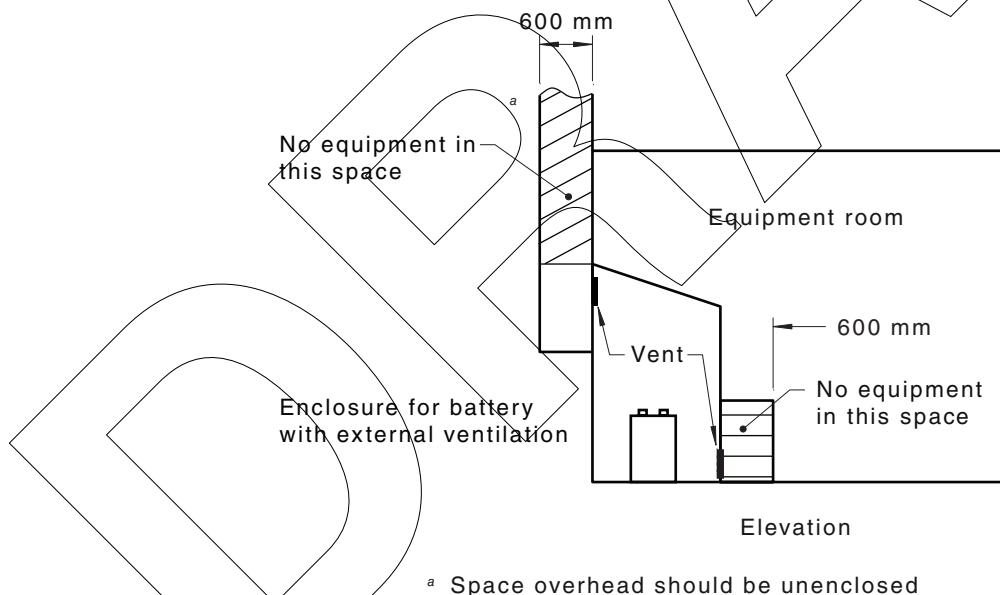

**Figure 6.16 — Battery system enclosure within a room where the battery system enclosure is vented to outside the building**



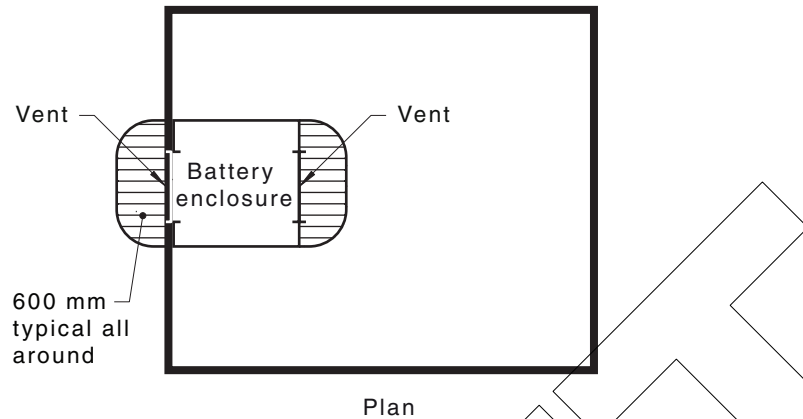

**Figure 6.17 — Battery system enclosure within a room where the battery system enclosure is vented to outside the building**

### 6.3.6 Mechanical hazard

#### 6.3.6.1 General

In addition to the requirements specified in [Clause 6.2.8](#) the installation of the battery system or BESS shall be in accordance with the following:

- For a ground mounted battery system or BESS, the ground structure and type shall have structural strength to support the battery system or BESS weight.
- For a wall-mounted battery system or BESS, the structural integrity of the wall shall be able to withstand the weight of the battery system or BESS.

NOTE [Table 3.1](#) shows those battery types categorized as mechanical hazards.

#### 6.3.6.2 Additional requirements for battery system and BESS enclosures

In addition to the enclosure requirements specified in [Clause 6.2.5](#), the installation of the battery system or BESS enclosure shall be in accordance with the following:

- The supporting surfaces or racks within the enclosure shall have structural strength to support the battery, battery modules or battery system weight.
- The deflection of the racks in the enclosure, after installation of the batteries or battery modules and after normal settlement has taken place under load, shall not be more than 3 mm.
- Any battery stand shall meet the requirements specified in [Clauses 6.3.6.3](#) and [6.2.7](#).

#### 6.3.6.3 Additional recommendations for battery system rooms

Battery system room requirements are specified in [Clause 6.2.6](#) and the battery stand requirements in [Clause 6.2.7](#). The following recommendations apply to the installation of the battery stand in a room:

- The deflection of the racks in the battery stand, after installation of the batteries or battery modules and after normal settlement has taken place under load, should not be more than 3 mm.
- The projected area of the base of the battery or battery module should be contained within the stand.
- Horizontal restraining bars should be installed at the front and back of the battery stands, if the height of the battery or battery module is its greatest dimension.
- The consequences of seismic activity should be considered.



NOTE See [Appendix C](#) for typical battery stands.

#### 6.3.6.4 Moving parts

Any equipment having hazardous moving parts shall be protected to prevent inadvertent personal contact with these parts. Where such protection has not been provided by the manufacturer, guards shall be fitted and instructions included in the equipment's safety and handling documentation.

#### 6.3.7 Toxic fume hazard

##### 6.3.7.1 General

Where the battery system type is categorized as a toxic fume hazard in [Table 3.1](#) the batteries, battery modules or battery system shall be installed according to the manufacturer's instructions. Any instructions provided by the manufacturer shall be included in the documentation provided to the system owner (or nominated representative) and they shall be made aware of these instructions.

The battery system manufacturer or the SDS should be consulted when assessing the risk level of toxic fume hazard for the specific battery chemistry. The use of overvoltage protection system applicable for the battery chemistry may reduce the production of toxic fumes generated to below safe levels of toxicity for some battery chemistries.

NOTE As an example, over voltage protection includes a requirement for temperature compensated charge voltage management for lead acid batteries.

Where no instructions have been provided by the manufacture and toxic fumes may be generated by the battery system then the risk of toxic fume exposure shall be mitigated by the methods detailed in [Clause 6.3.7.2](#).

##### 6.3.7.2 Battery system rooms and enclosures requirements

Where the battery system type is categorized as a toxic fume hazard in [Table 3.1](#) the enclosure or room shall —

- (a) be made of materials suitable for the containment of the battery system's toxic fumes; and
- (b) be vented to ensure toxic fumes are vented outside of building to minimize levels below safe levels of toxicity.

Ventilation to the outside shall not be located in restricted locations for battery systems or BESS (see [Clause 6.2.2.2](#)).

NOTE 1 Some toxic fumes are heavier than air, such as HF that is produced by lithium ion base battery technology. As such both inlet and outlet vents need to be considered.

NOTE 2 Refer to Safe Work Australia or WorkSafe New Zealand for information regarding workplace exposure standards for airborne contaminants.

Where possible, natural ventilation should be used for battery system rooms and enclosures because of the fault potential of mechanical ventilation may result in unsafe levels of toxicity.

Where mechanical ventilation is used, the minimum flow rate shall keep toxic fumes below safe levels of toxicity.

An air flow sensor shall also be installed to activate an alarm and discontinue charging in the event of a fan failure.

## 6.4 System documentation, verification and commissioning

### 6.4.1 Documentation

#### 6.4.1.1 General

At the completion of the installation of a battery system or a battery energy storage system, documentation shall be provided in accordance with the requirements of this Clause. This documentation shall ensure that key system information is readily available to customers, inspectors, maintenance service providers and emergency service personnel.

#### 6.4.1.2 System manual

A manual, complete with the following items, shall be provided:

- (a) Battery system information including the following:
  - (i) Total battery storage capacity.
  - (ii) Australian and/or New Zealand address and contact details for the manufacturer's representative (or deemed equivalent).
  - (iii) UN Number for the battery cell or battery system.
  - (iv) Commissioning date.
  - (v) System provider contact details.
- (b) A complete list of installed equipment, with model description and serial numbers.
 

NOTE 1 It is recommended that installers retain records of equipment installed for maintenance and records.
- (c) System performance and operation configuration: system output performance including expected operating response based on programming, expected life of battery system (including information of state of health where provided by the system), end of life system parameters and expected operational life.
- (d) Operating instructions (systems and components): a short description of the function and operation of all installed equipment.
- (e) Operational instructions for response requirements to alarms including earth fault alarms, battery management system alarms, smoke alarms, ventilation alarms and any other alarms that may be required as part of the installation.
- (f) Description and meaning of any state of health measurements, where provided.
- (g) Shutdown and isolation procedure for emergency.
- (h) Start-up procedure and verification checks.
- (i) Description of how to identify when system is not operating correctly and what to do in the case of a system failure. Details about alarm systems installed as part of the system and in addition to the system.
- (j) Maintenance procedures and schedule: maintenance procedures, a checklist for the installed equipment and schedule for these tasks including hazard mitigation requirements for maintenance tasks. Including shutdown and isolation procedure for maintenance.
- (k) Commissioning records and installation checklist: A record of the initial system settings and firmware version at the time of system installation, verification records and commissioning checklists for quality assurance

- (l) System connection diagram: A diagram showing the electrical connections of the battery system with the PCE(s). See [Section 7](#) for correct labels to match all the diagram labels.

NOTE 2 In larger installations separate schematic circuit and wiring diagrams should be provided.

- (m) Equipment manufacturer's documentation, data sheets, safety data sheets (SDS) for batteries and handbooks — for all equipment supplied. Where systems have an Ethernet or other form of data interface, include all information on connection requirements and system operating manuals.
- (n) Information on specific requirements to address all risks (for example, the action to take when toxic fumes are present).
- (o) List of any spare parts that have been provided (e.g. fuse replacement cartridges).
- (p) Decommissioning information for battery replacement or battery removal (including recommendations for battery recycling).

NOTE 3 An electronic version of documentation is acceptable.

## 6.4.2 Verification

### 6.4.2.1 General

The verification of a battery system shall be carried out in accordance with the requirements of AS/NZS 3000 for verification prior to energizing and placing the installation into service. These requirements represent minimum standards of inspection and testing to meet the minimum safety requirements for the installation. Upon completion of the verification process a report shall be provided for inclusion in the system documentation.

### 6.4.2.2 Initial verification and visual inspection

Prior to energizing and placing the installation into service, conformance of the battery system to AS/NZS 3000, the manufacturer's instructions and the following requirements shall be verified:

- (a) All system shutdown and start up notifications shall match system diagrams and system labelling.
- (b) Signs, labels and markings shall be installed and applied in accordance with the requirements of [Section 7](#).
- (c) Any system risk-reduction isolation devices shall operate and be accessible; such as battery system isolators for the purposes of maintenance and future work.
- (d) All terminal connections shall be tightened to the specified torque settings.
- (e) All necessary ancillary safety devices and equipment shall be installed.

### 6.4.2.3 Alterations and repairs

Where there is an alteration or repair to a battery system installation, the electrical installation from the battery system terminal to the PCE port shall be verified to ensure that the alteration or repair is in accordance with this Standard and does not impair the safety of the existing electrical installation.

NOTE Any alterations to the PCE installation need to maintain conformance to the relevant PCE installation standard.

### 6.4.2.4 Testing

The testing of the installation shall be performed in accordance with the requirements of the manufacturer and the requirements AS/NZS 3000.

Where the installation has a separate battery system, battery polarity shall be tested prior to connection to PCE. Testing shall ensure no inadvertent connections between floating or isolated battery systems and earth.

The following measurements should be undertaken and results recorded in the commissioning documentation:

- (a) Total battery system voltage.
- (b) Individual battery or battery module voltages, if applicable.
- (c) Other suitable measurements, where applicable, such as specific gravity readings of individual battery cells, impedance test results of individual battery cells or initial state of health.
- (d) Overall battery system voltage drop from cabling at maximum rated discharge current.

### 6.4.3 Commissioning

#### 6.4.3.1 General

System commissioning shall include verification that the system as a whole operates and, in particular, the battery system operates in both charge and discharge modes.

At installation commissioning, all d.c. connections shall be tested while the system is operating at full discharge or charge current to ensure there are no poor connections.

Operational parameters that are configured at installation for the control of the battery system shall be verified (whether this is done through the PCE directly or through a data connection or host computer connection). Remote monitoring where included with the battery system should be configured so access is available to the system owner or nominated representative.

The system shutdown procedure shall be tested to ensure this results in safe shutdown of the installation.

Any commissioning requirements of the manufacturer shall be followed. For some battery types specific instruction on initial charging and discharging are provided.

#### 6.4.3.2 Induction

An induction shall be provided to the system owner or nominated representative. This induction shall include the following:

- (a) Demonstration of the system shutdown and start up procedures including review of shutdown procedure sign.
- (b) Introduction to the system manual provided as part of the installation.
- (c) Provision of detailed information for any alarm features included in the system.
- (d) Clear information on contact details for provision of assistance.
- (e) Information pertaining to the access to specific data or hosted system information including user logins, available apps or programs.
- (f) Basic operation and design principals.
- (g) Periodic inspection and maintenance requirements.

NOTE Guidance on inspection and maintenance is provided in [Appendix H](#).

## Section 7 Labels and safety signage

### 7.1 General

The purpose of the provisions of this Section is to clearly indicate that the electrical installation has a battery system installed and to provide required safety signs and labels. These signs are additional signs to those required by other Standards (e.g. AS/NZS 4777 and AS/NZS 4509).

Signs relating to the battery system shall be placed as detailed in this Section in relation to the specific location in the electrical installation.

To provide assistance for emergency services, additional signs should be provided at fire indicator panels, where used.

Additional signs may be required by relevant authorities or electricity distributors.

NOTE Typical examples of these signs are provided in [Appendix B](#).

### 7.2 Requirements for signs and labels

All signs required in this Section shall be —

- (a) sufficiently durable and designed to have a lifetime greater than or equal to the service life of the battery system or BESS;
- (b) constructed of durable materials suitable for the location, and where installed exposed to direct sunlight, shall use UV stabilized materials;
- (c) fixed in a durable manner;
- (d) in English;
- (e) legible and in a letter size appropriate for the location (see guidance in Note 1);
- (g) indelible; and
- (h) visible, as required, at the installed position.

Signs should not be —

- (i) obscured by being located inside cupboards, behind doors or other materials;
- (ii) located where they can be obscured by materials placed in front of them or be located where it is likely that material will be placed in front of them (e.g. immediately above a shelf); and
- (iii) obscured by the door of the enclosure when in an open position.

Some battery signs may need to be within the battery system enclosure and may only become visible after opening the battery system enclosure.

NOTE 1 Sign lettering should be sized with upper case lettering of 5 mm high and lower case of 4 mm high per metre of viewing distance

NOTE 2 As a guide, the background colour and lettering colour should follow the principles listed below:

- (a) Signs for general information should be white with black lettering.
- (b) Signs for the essential safety of service personnel should be yellow with black lettering with a warning symbol.
- (c) Signs for attention of emergency personnel should be red with white lettering.
- (d) Signs for personal protective equipment should be blue with white contrasting symbol.

- (e) Special signs may use other colours or additional designations.

### 7.3 Battery type general labelling

Locations where battery energy storage systems are installed shall require a circular green reflector sign at least 70 mm in diameter with the letters “ES” on or immediately adjacent to the main metering panel and main switchboard, so as to be readily visible to approaching emergency workers. Below the “ES” lettering shall be included the United Nations number for the primary chemistry installed at the installation, e.g. UN No: 2794.

### 7.4 Signs for battery system location

Battery system locations that are difficult to find, not evident from the main metering panel or in large buildings should be shown on a plan (map or drawing) located at the main switchboard and/or fire panel. This plan shall indicate the location of shutdown procedures.

### 7.5 Restricted access

Battery systems that are accessible within an enclosure or room shall have a sign which —

- (a) designates “DANGER”, “restricted access” stating that access is permitted only for authorized personnel; and
- (b) is mounted either adjacent to the enclosure or on all doors to the room where the battery system is located.

Signs relating to PPE requirements shall be located adjacent to the restricted access sign.

### 7.6 Voltage and current

A sign stating voltage and current shall be mounted either adjacent to the enclosure or on all doors to the battery system room.

This sign shall state the following:

- (a) The words “Battery System”.
- (b) Short-circuit current (specify current in amperes).
- (c) Maximum d.c. voltage (specify voltage in volts).

For systems over DVC-A, the above signage requirements apply plus an additional line shall be added to the sign stating “Hazardous d.c. voltage”.

Where multiple battery systems are installed the following apply:

- (i) Only one sign is required if the battery systems are all in the same room/enclosure.
- (ii) The voltage specified shall be the maximum voltage present.
- (iii) The current shall be maximum short circuit current calculated for any of the BESS, where for each BESS that has multiple battery systems connected in parallel the calculated current shall be the sum of the battery system short-circuit currents of each or the paralleled battery systems.

Where multiple BESS are installed within one electrical installation, there shall be a sign for each BESS that includes an identifiable number together with the total number of BESS shown. For example, BESS 1 of (insert total number of BESS), BESS 2 of (insert total number of BESSs).



## 7.7 Safety data sheet (SDS)

The SDS for the battery system shall be included within a document holder in the main switchboard, and, where available, at the fire panel. The SDS shall ensure a local contact (country contact, Australia or New Zealand, as appropriate) within the document.

## 7.8 Explosive gas hazard

All battery system types categorized as explosive gas hazards shall have a “Danger, Risk of Battery Explosion” sign installed in a prominent position when approaching the battery system. The minimum size of this sign shall be 175 mm × 175 mm. This sign shall be mounted either adjacent to the enclosure or on all doors to the room where the battery system is located.

## 7.9 Toxic fume hazard

All battery system types categorized as toxic fume hazard shall have a sign: “Danger, toxic fumes”. The sign shall specify the specific fault condition (e.g. fire) under which the fumes will be present. This sign shall also include PPE requirements for entering the room/working with the battery systems. This sign shall be mounted either adjacent to the enclosure or on all doors to the room where the battery system is located.

## 7.10 Chemical hazard

All battery system types categorized as chemical hazards shall carry an appropriate sign specifying what to do if the skin, eyes or other parts of the body are exposed to the chemical. This sign shall be mounted either adjacent to the enclosure or on all doors to the room where the battery system is located.

## 7.11 Arc flash

All battery system types categorized as having an arc flash hazard above “minor” (see [Table 6.1](#)) shall carry a warning sign to indicate the dangers of arc flash. This sign shall be mounted either adjacent to the enclosure or on all doors to the room where the battery system is located.

Work health and safety (WHS) regulations may require signs indicating the need for personal protective equipment (PPE).

## 7.12 Disconnection devices

### 7.12.1 General

Disconnection devices shall be marked with an identification name or number according to the BESS wiring diagram and consistent with the shutdown procedure. The minimum size of this sign shall be such that it can be read from a distance of 1 m.

All switches shall clearly and reliably indicate the isolating position of the device. The symbols “0” (off) and “I” (on) are deemed to satisfy this requirement.

### 7.12.2 Battery system isolation device

The battery system isolation device shall carry a sign fixed in a prominent location with the following text “BATTERY SYSTEM D.C. ISOLATOR”.

NOTE The term “isolator” used in this sign is to better inform the public, although the function required of the device is load breaking.



### 7.12.3 Multiple isolation device

When a battery system has more than one isolation device installed, these shall be labelled and numbered according to the battery system to which they are connected.

Where there are parallel battery systems connected to the PCE(s) and multiple isolation/disconnection devices are used, the following signage shall be fixed adjacent to the PCE connected to the multiple battery systems and have a warning label containing a warning symbol and stating:

**WARNING — MULTIPLE BATTERY SYSTEMS**

TURN OFF ALL BATTERY SYSTEM ISOLATORS TO ISOLATE EQUIPMENT

If there are multiple PCEs, only one sign is required to be located beside one of the PCEs.

NOTE A typical example is shown in [Figure B.13](#).

### 7.12.4 Disconnectors for DVC-B and DVC-C systems

Isolating switches, interconnecting connectors, cables or links used to separate the battery system into sections to meet the requirements of [Clauses 6.3.1.3.5](#) shall be fixed adjacent to each disconnector and have a warning label containing a warning symbol and stating:

**WARNING — DO NOT DISCONNECT UNDER LOAD.**

All internal isolating devices shall also be suitably identified for breaking down of the battery system to offset particular maintenance and access requirements.

## 7.13 Overcurrent devices

### 7.13.1 General

Overcurrent devices shall be marked with an identification name or number in accordance with the BESS wiring diagram. The minimum size of this sign shall be such that it can be read from a distance of 1 m.

Where a circuit breaker is used as the main battery system isolator it shall be labelled as follows (see [Clause 7.12.2](#)):

BATTERY SYSTEM D.C. ISOLATOR

NOTE A typical example is shown in [Figure B.12](#).

### 7.13.2 Multiple overcurrent devices

When a battery system has more than one overcurrent device installed, these shall be labelled and numbered according to the battery system to which they are connected.

### 7.13.3 Fuse holders

Where HRC fuse holders that are separate to the switch-disconnector have been installed, each fuse holder shall carry a warning label stating not to withdraw the fuse under load. The minimum size of this sign shall be such that it can be read from a distance of 1 m.

## 7.14 Battery system cables

For battery system cabling, which is not enclosed in conduit, permanent indelible identification shall be —

- (a) provided for battery system cabling installed in or on buildings;
- (b) provided by distinctive and coloured labels marked with the word “BATTERY”; and

(c) attached over the length of that cable at an interval not exceeding 2 m.

For battery system cabling, which is housed in a wiring enclosure or in conduit, permanent indelible identification shall —

- (i) be provided for the enclosure and conduit; and
- (ii) be identified by distinctive and coloured labels marked with the word “BATTERY” on the exterior surface over the length of the enclosure at intervals not exceeding 2 m.

If fixed to a surface, the identification shall be visible following complete installation of the battery system.

### 7.15 Segregation

For the purpose of segregation, as required in [Clauses 5.3.1.6](#) and [6.3.1.7](#), labels to identify the different types of circuits shall be mounted beside the relevant circuits.

If the different types of circuits require labelling over a length of the cable, these labels shall be attached over the length of that cable at an interval not exceeding 2 m.

### 7.16 Shutdown procedure

All BESS shall include a permanent sign detailing the shutdown procedure that sets out the sequential steps to safely shut down the BESS.

The shutdown procedure shall be —

- (a) installed adjacent to the PCE to which the battery system is connected; and
- (b) placed adjacent to and visible from the equipment to be operated in the event of a shutdown.

Where the PCE is adjacent to the switchboard it is directly connected to, the shutdown procedure may be placed within that switchboard.

The sign detailing the shutdown procedure may also include the start-up procedure.

All labelling of devices shall be consistent with terminology used in the shutdown procedure.

A warning shall be included in the shutdown procedure indicating that isolation of the battery system by isolation and shutting down the PCE may not de-energize the battery system and further action may be required.

The shutdown procedure should also include emergency telephone contact information.

### 7.17 Battery labelling

Where a battery system has individual cells or modules requiring or able to be accessed or serviced, each individual cell or module is required to have a unique identifier including the use of consistent terminology. The label shall be placed on each cell or module such that it can be read without moving the cell or module.

Where there is a BMS for the cells or modules, the labelling shall be consistent with identification from the BMS.

### 7.18 Other equipment labelling

All meters, shunts and alarms shall be labelled. Labels shall match naming conventions used in battery system documentation and drawings.

Additional warning signs may be required when specific protection systems are installed (e.g. additional fire suppression system).

### 7.19 Spill containment

Information signs informing the actions to be undertaken in the event of a chemical spillage or leak shall be installed adjacent to the battery system.

PUBLIC COMMENTING DRAFT

DRAFT

## Appendix A (informative)

### Decisive voltage classification (DVC)

The level of shock hazard is informed by the decisive voltage classification. If the battery is within the DVC-A voltage range, and the port to which it is connected is also DVC-A, then the battery is considered relatively safe from the point of view of electric shock but it still may constitute an energy hazard.

However, if the battery system voltage is within the DVC-A voltage range (e.g. 48 V) but the port to which it is connected is considered DVC-C, the whole battery system becomes DVC-C. The port may be classified as DVC-C simply because the PCE and hence the battery system, although of a DVC-A voltage, is effectively connected to DVC-C level voltage (via the grid or PV array with an open-circuit voltage  $V_{oc}$ , rated at DVC-C).

If multiple pieces of equipment are connected directly to a circuit, the port with the highest DVC classification directly connected to the circuit determines the final DVC classification of that circuit.

The use of DVC port classifications therefore informs the designer or installer on the safety measures required to be implemented for the battery system, in terms of electrical protection and enclosures and interlocks.

Where the DVC classification of a port of a piece of equipment connected to a battery system is not available (as may be the case for a charge controller), the technology of the piece of equipment is an important consideration. If the charge controller has an input voltage greater than DVC-A, and does not provide the equivalent of double insulation/separation between the battery port and the input voltage, the battery system must be classified to be a higher classification (e.g. DVC-B or DVC-C), according to the voltage classification of the input voltage of the charge controller.

For the purposes of this Standard, where equipment used in a battery system is either DVC-B or DVC-C, it should be treated as “low voltage” as defined in Section 1 of AS/NZS 3000.

## Appendix B (informative)

### Safety signs

#### B.1 UN number in battery type sign

The UN number refers to the type of chemical within the battery system. This number links to SAA/SNZ HB 76 which is used by first responders in the case of an emergency. SAA/SNZ HB 76 provides information on how to handle the hazard and respond. [Table B.1](#) provides the UN numbers for the most common battery types.

**Table B.1 — UN number of battery types**

UN number	Battery chemical type
UN 3480	Lithium ion (including ion polymer)
UN 3090	Lithium metal batteries
UN 2794	Flooded lead acid battery
UN 2800	Valve regulated lead acid battery
UN 3496	Nickel-metal hydride battery
UN 2795	Nickel cadmium battery
UN 3292	Sodium ion batteries

#### B.2 Typical signs



NOTE 1 Insert UN number to suit battery type.

NOTE 2 See [Clause 7.3](#).

**Figure B.1 — Example sign for energy storage label required at main metering panel and main switchboard**

# EMERGENCY EVACUATION DIAGRAM

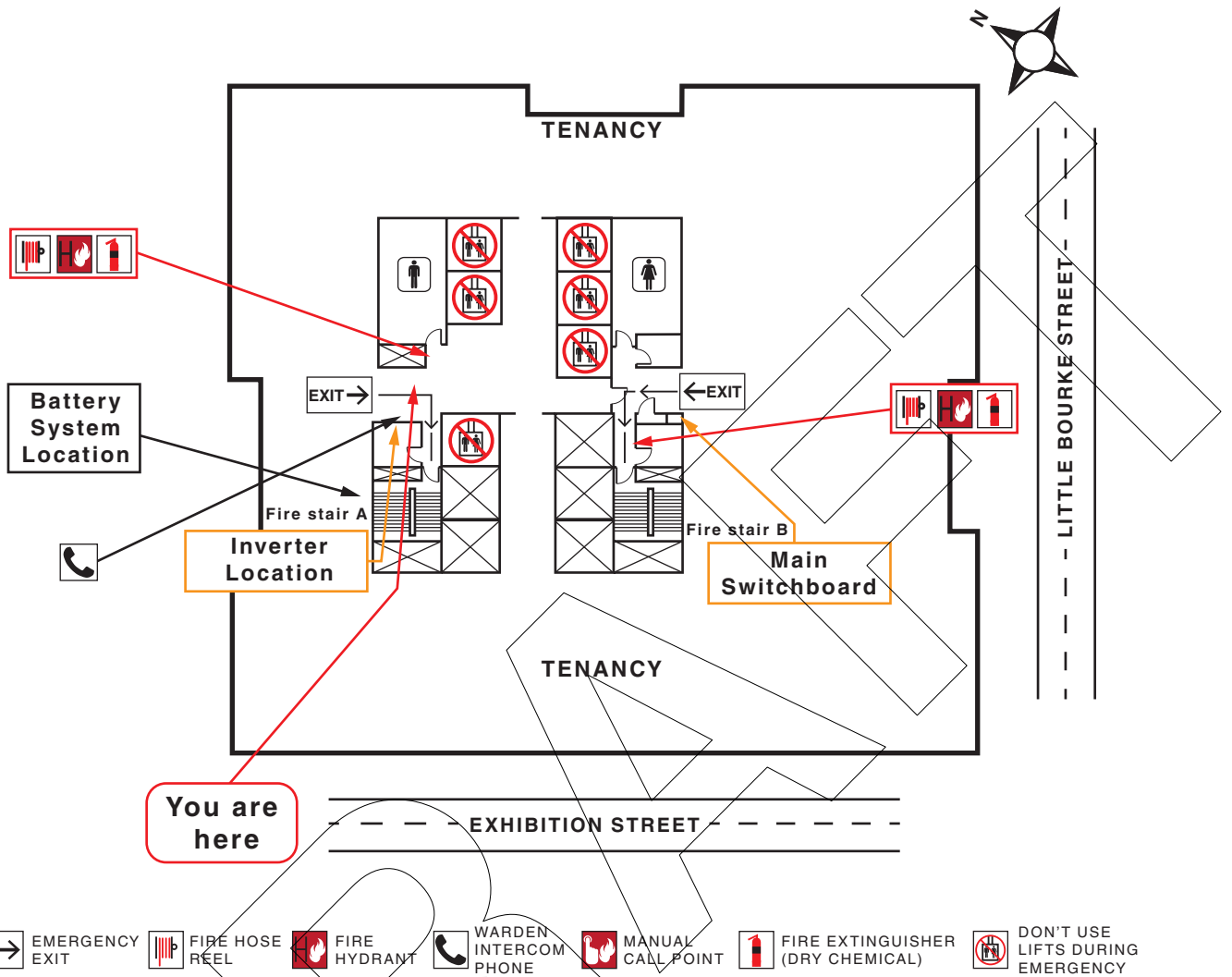

NOTE See [Clause 7.4](#).

Figure B.2 — Typical sign for battery system location to be placed at the main switchboard and/or fire/panel

PUBLIC COMMENTING DRAFT



NOTE See [Clause 7.5](#).

Figure B.3 — Typical sign for restricted access



NOTE See [Clause 7.5](#).

Figure B.4 — Typical signs of specific PPE requirements

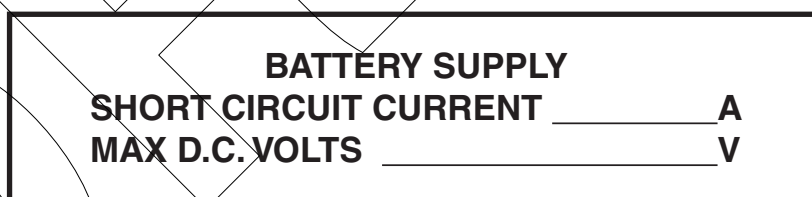

NOTE See [Clause 7.6](#).

Figure B.5 — Typical sign for battery system voltage



PUBLIC COMMENTING DRAFT

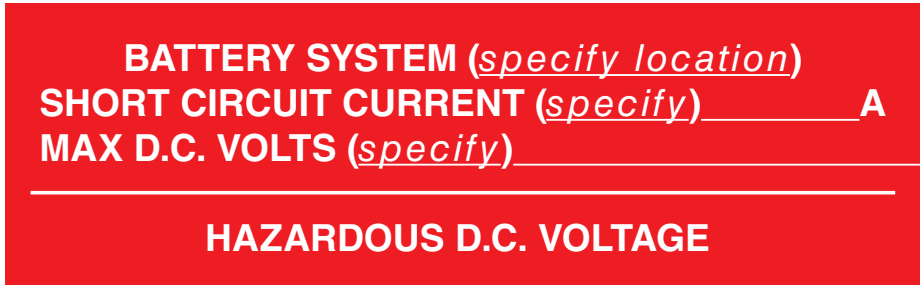

NOTE See [Clause 7.6](#).

Figure B.6 — Typical sign for battery system with voltage greater than DVC-A

Installed within one electrical installation where each individual BESS shall be identified. [Figure B.7](#) shows BESS #1/4, meaning this is BESS no.1 of a total of 4 BESS.

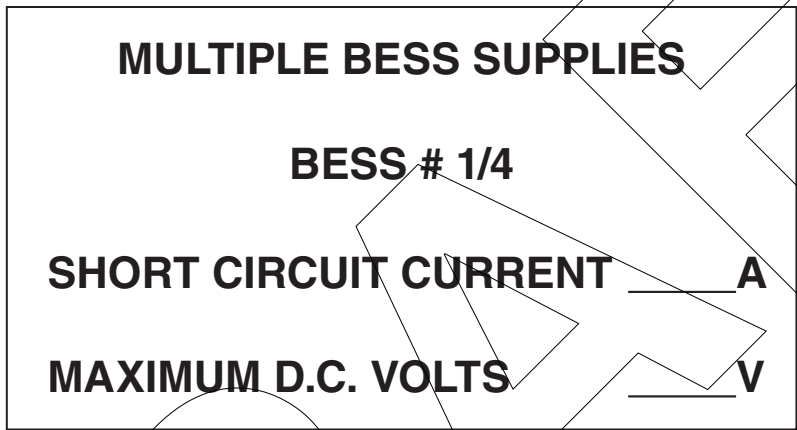

NOTE See [Clause 7.6](#).

Figure B.7 — Typical sign for battery system having multiple BESS

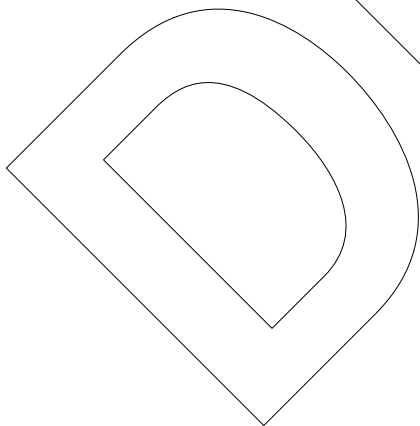

NOTE See [Clause 7.8](#).

Figure B.8 — Example sign for explosion hazard



NOTE See [Clause 7.9](#).

Figure B.9 — Example sign for toxic fumes hazard

**ELECTROLYTE BURNS**  
Immediately wash affected area with plenty of water then...

<p><b>SKIN BURNS</b></p> <ol style="list-style-type: none"> <li>1. If possible remove, or saturate contaminated clothing with water.</li> <li>2. If patient is distressed, take patient to doctor.</li> </ol>	<p><b>EYE BURNS</b></p> <ol style="list-style-type: none"> <li>1. Immediately wash eyes with large amounts of water using emergency eyewash bottle</li> <li>2. All cases of eye burn, after rendering first aid, take patient immediately to a doctor.</li> </ol>
---	---

**NOTE:** Doctor must be advised of type of burn  
 (a) Lead/acid battery—dilute sulphuric acid electrolyte.  
 (b) Nickel/cadmium battery—potassium hydroxide alkali electrolyte.

**PRECAUTION:** 1. Always wear protective clothing when dealing with electrolyte.

NOTE See [Clause 7.10](#).

Figure B.10 — Example sign for electrolyte burns

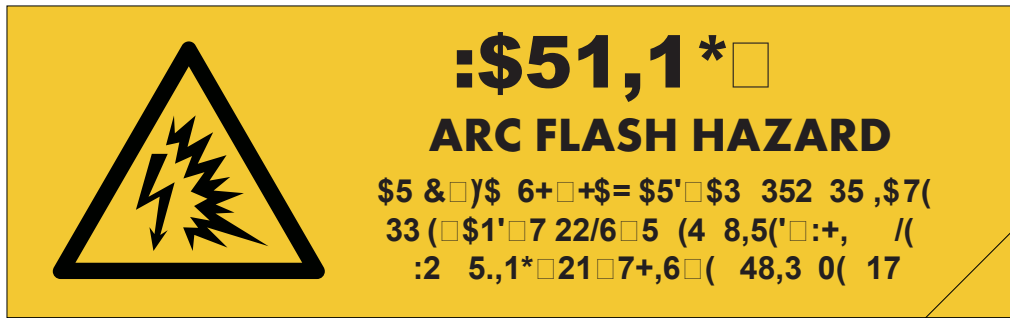

NOTE See [Clause 7.11](#).

Figure B.11 — Example sign for arc flash hazard



NOTE See [Clause 7.12.2](#).

Figure B.12 — Typical battery system isolator sign

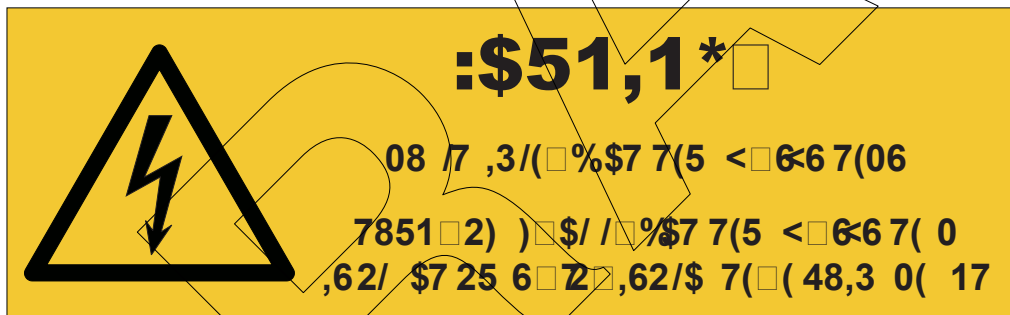

NOTE See [Clause 7.12.3](#).

Figure B.13 — Typical battery system isolator sign



NOTE See [Clause 7.12.4](#).

Figure B.14 — Typical warning sign for isolation switches for battery systems above DVC-A

PUBLIC COMMENTING DRAFT

# BATTERY SYSTEM CIRCUIT BREAKER

NOTE See [Clause 7.13](#).

Figure B.15 — Typical sign for overcurrent device labelling

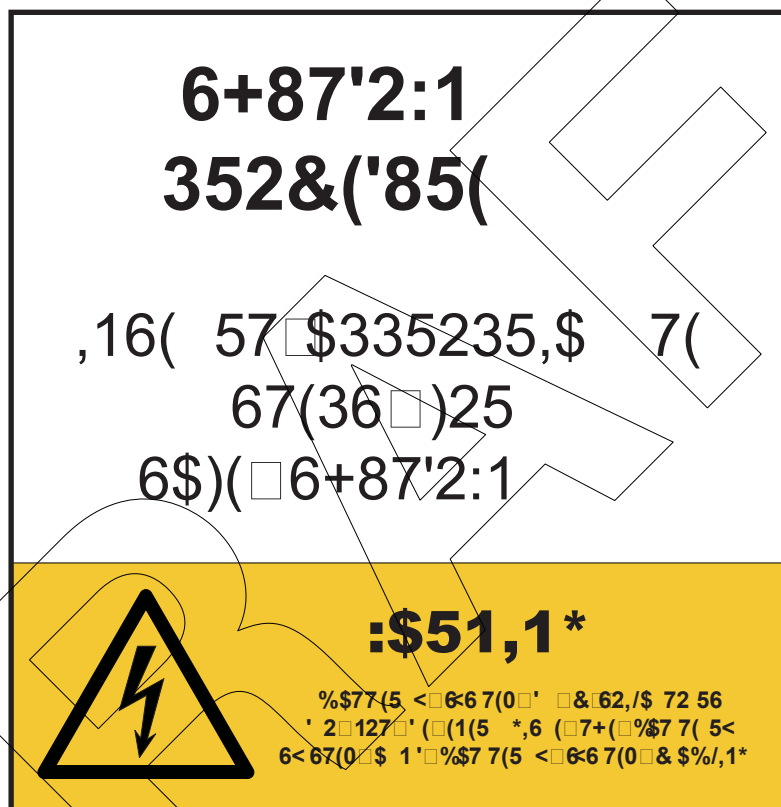

NOTE See [Clause 7.16](#).

Figure B.16 — Shutdown procedure notice

PUBLIC COMMENTING DRAFT

PUBLIC COMMENTING DRAFT

**THIS ENCLOSURE IS PROTECTED  
BY AN ABC AEROSOL FIRE  
SUPPRESSION SYSTEM. OPEN  
DOORS WITH CARE AND  
VENTILATE COMPLETELY  
AFTER DISCHARGE.**

NOTE See [Clause 7.18](#).

Figure B.17 — Fire system labelling

**IN THE EVENT OF LIQUID  
DETECTED IN THE BUND,  
USE LABELLED SPILL KIT  
AND PPE TO REMOVE LIQUID.  
REPORT FAILURE IMMEDIATELY  
TO SUPPLIER**

NOTE See [Clause 7.19](#).

Figure B.18 — Spill safety sign labelling

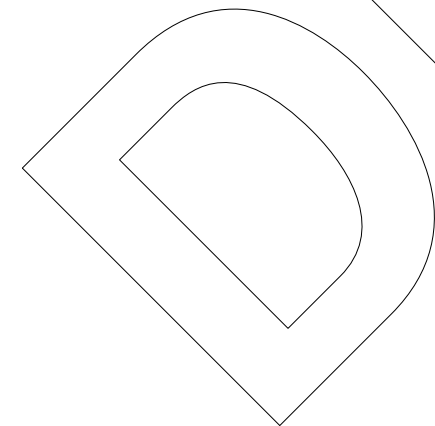

### Appendix C (informative)

#### Typical layout of battery rooms and stands

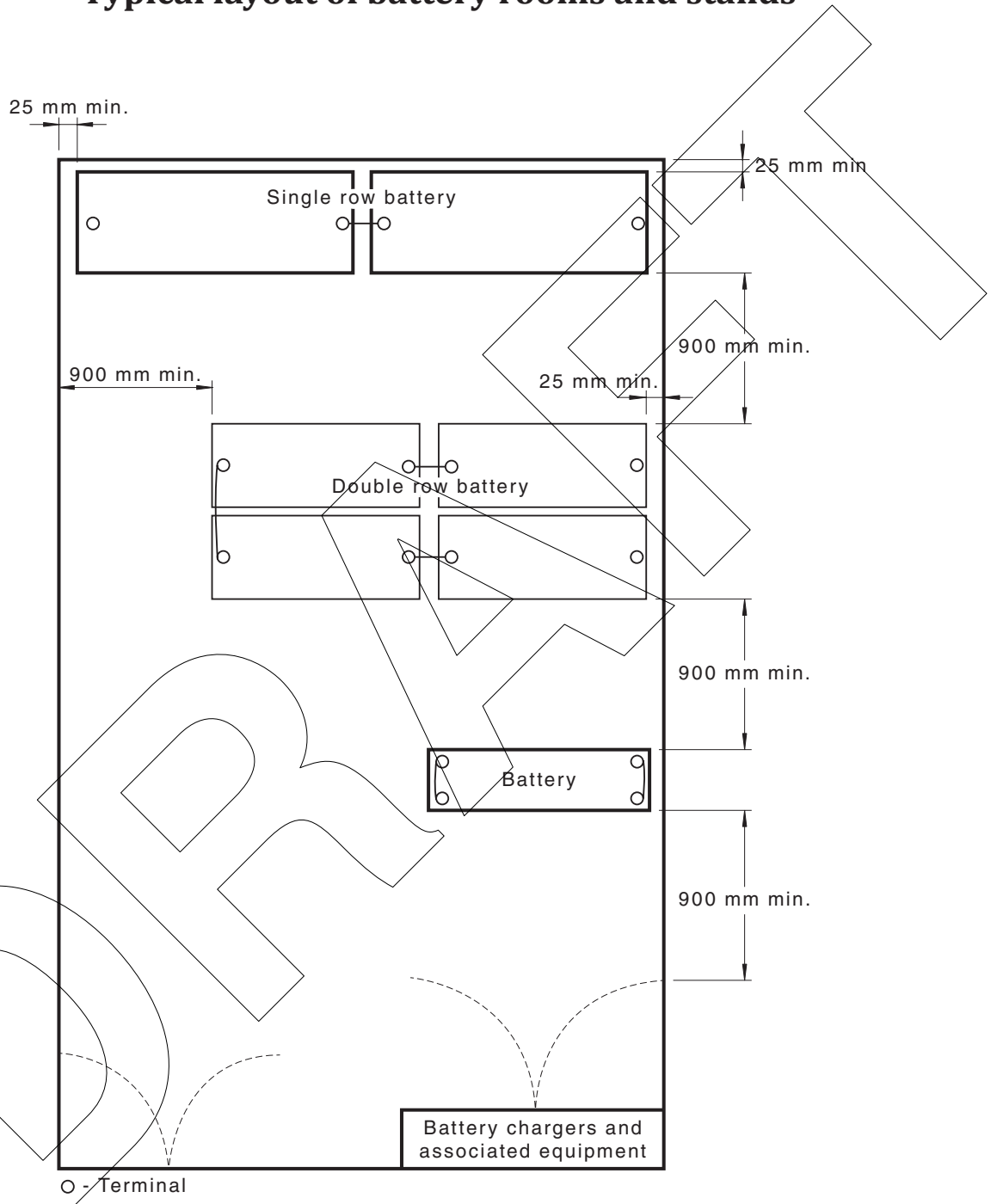
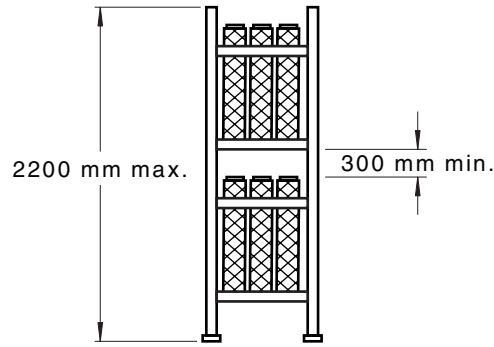
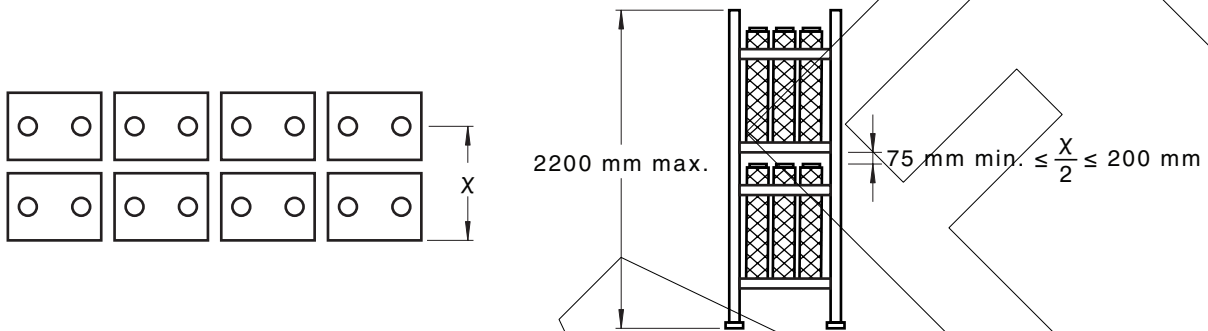

Figure C.1 — Minimum clearances in battery room

PUBLIC COMMENTING DRAFT

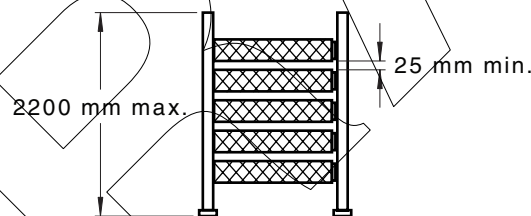

**Figure C.2 — Clearances for flooded cells/batteries (front view)**

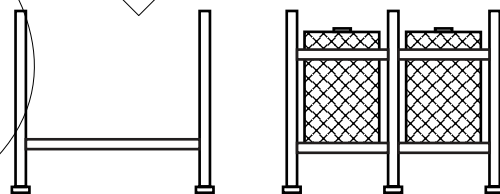

**Figure C.3 — Clearances for other types (front view)**

Figures C.4 to C.10 represent possible typical battery stands with single or double rows and/or single or double tiers. The additional bracing required for seismic (earthquake) conditions is not shown. See Clause 6.2.7 and 6.3.6.3 for these requirements.

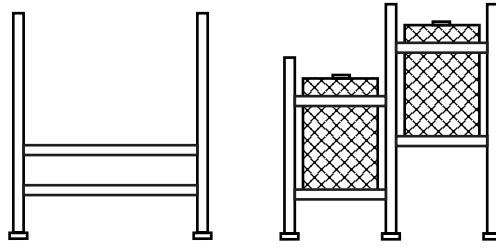

**Figure C.4 — Single-row, single-tier battery stand**

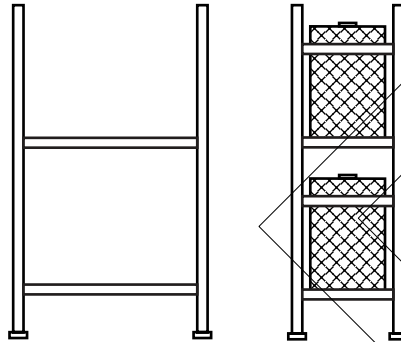

**Figure C.5 — Double-row, single-tier battery stand**

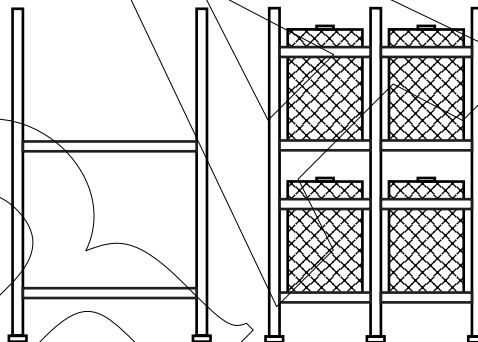



**Figure C.6 — Double row, single tier stepped battery stand**



**Figure C.7 — Single row, double tier battery stand**



**Figure C.8 — Double row, double tier battery stand**

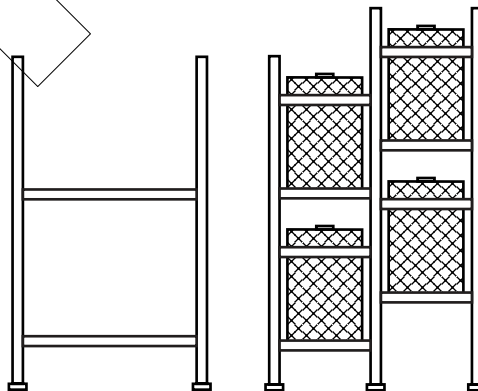

**Figure C.9 — Double row, double tier stepped battery stand**

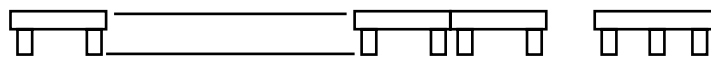

**Figure C.10 — Pallet battery stands**

PUBLIC COMMENTING DRAFT

DRAFT

## Appendix D (informative)

### Battery system enclosures examples for battery types classified as explosive gas hazards

Examples of acceptable arrangements for housing and ventilation of batteries are shown in [Figures D1 to D4](#). This is not an exhaustive set of possible arrangements.

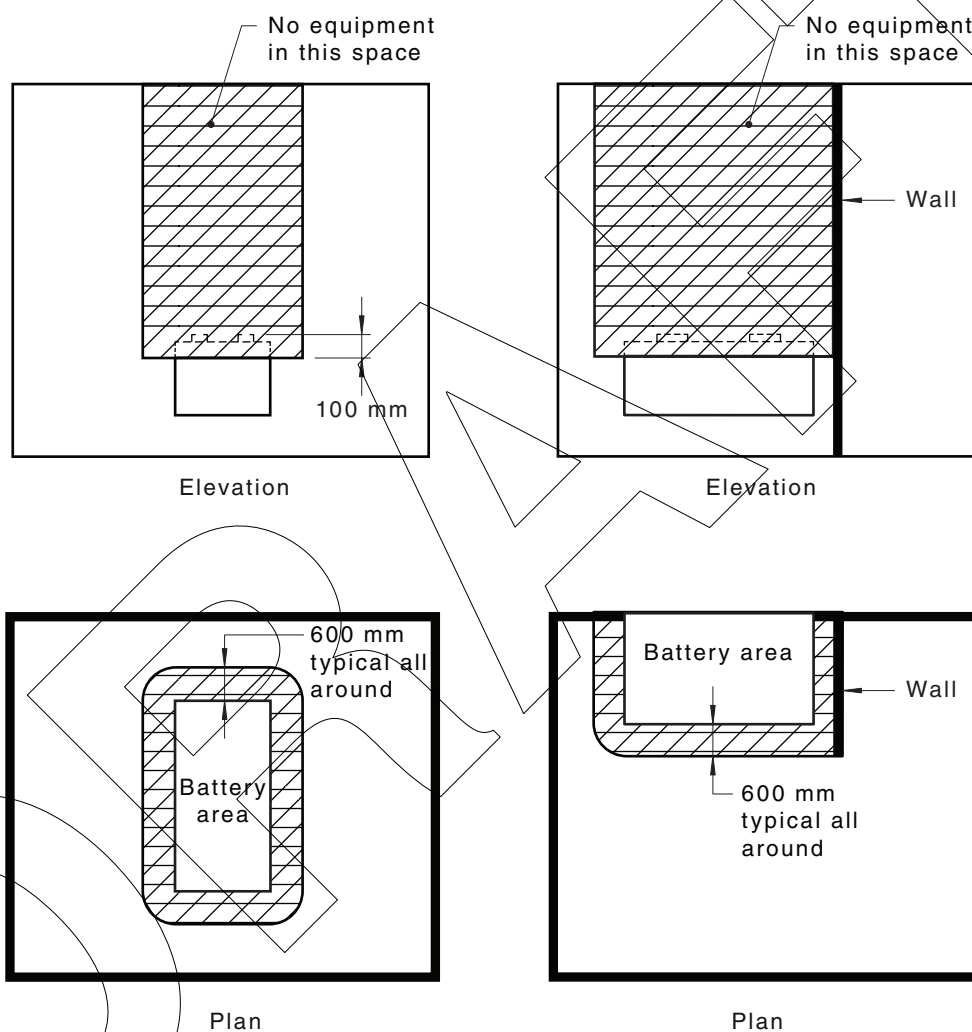

NOTE 1 This is a dedicated battery system or BESS room that is secured to prevent unauthorized entry.

NOTE 2 The battery system or BESS room is ventilated externally.

**Figure D.1 — Two example battery areas installed in a dedicated equipment room showing clearances from equipment**

PUBLIC COMMENTING DRAFT

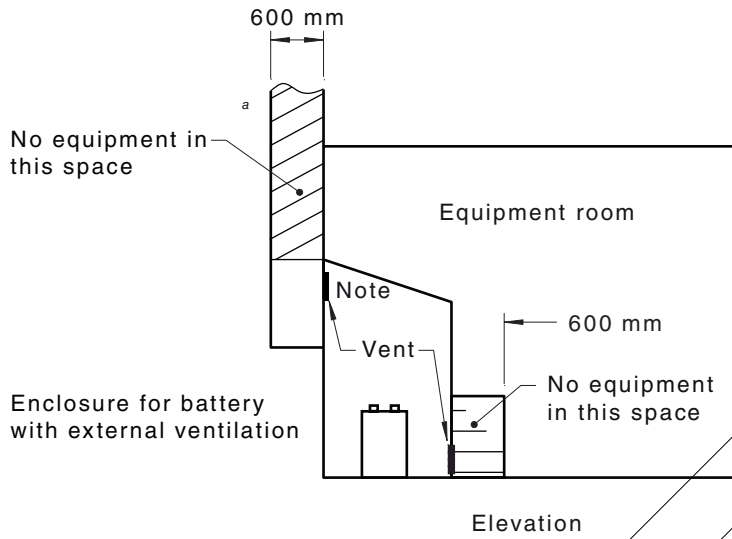

<sup>a</sup> Space overhead should be unenclosed or allow no hydrogen pockets to accumulate above

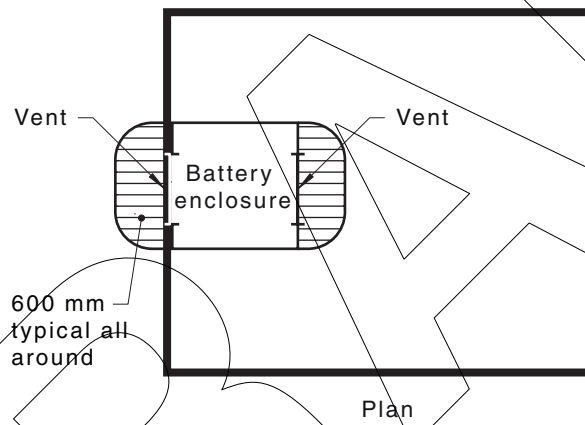

NOTE The battery system enclosure is ventilated externally.

**Figure D.2 — Example battery system enclosure within a room where the battery system enclosure is vented to outside the building**

PUBLIC COMMENTING DRAFT

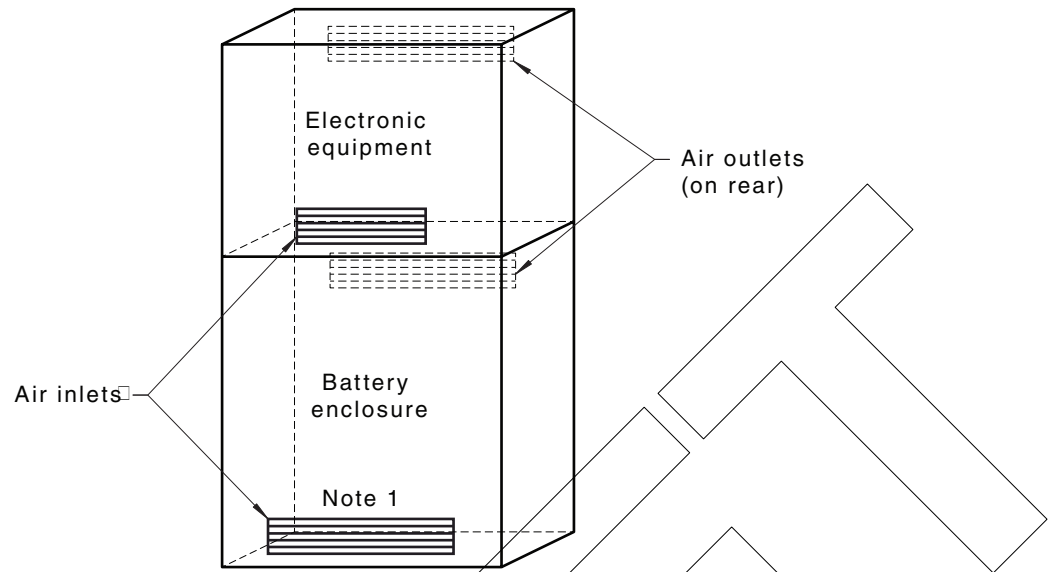

NOTE 1 The battery system enclosure is vented externally.

NOTE 2 The equipment enclosure may be vented externally or internally to room and separate to the battery vent.

NOTE 3 The battery and electronic inlet vents are on different sides to the outlet vents to provide cross flow ventilation.

NOTE 4 The barrier between battery system enclosure and electronics is sealed to prevent hydrogen ingress.

**Figure D.3 — Example battery system enclosure with equipment enclosure immediately adjacent**

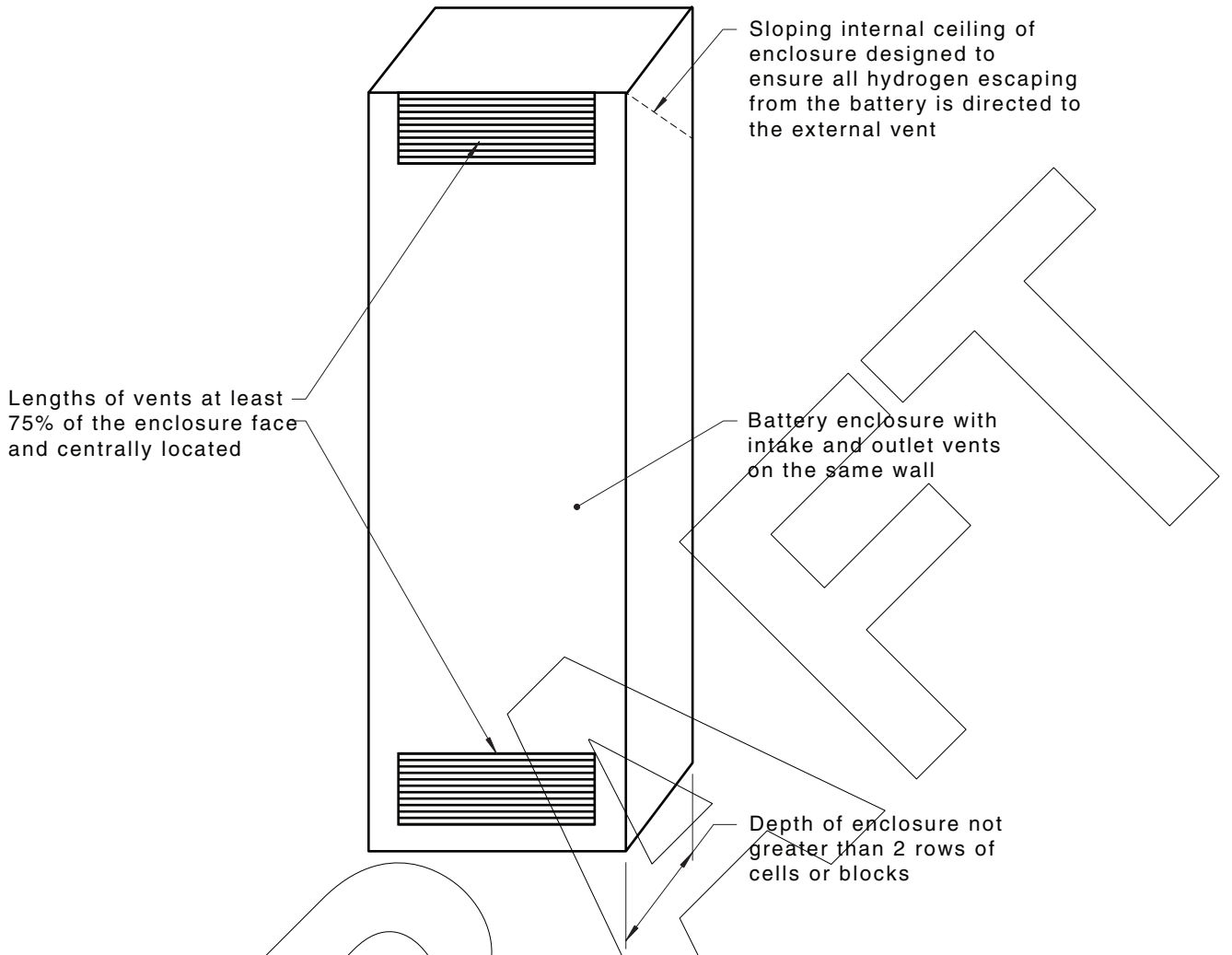

**Figure D.4 — Example battery system enclosure with the intake and outlet vents on the same wall**

## Appendix E (informative)

### Typical layouts for location and barrier requirements

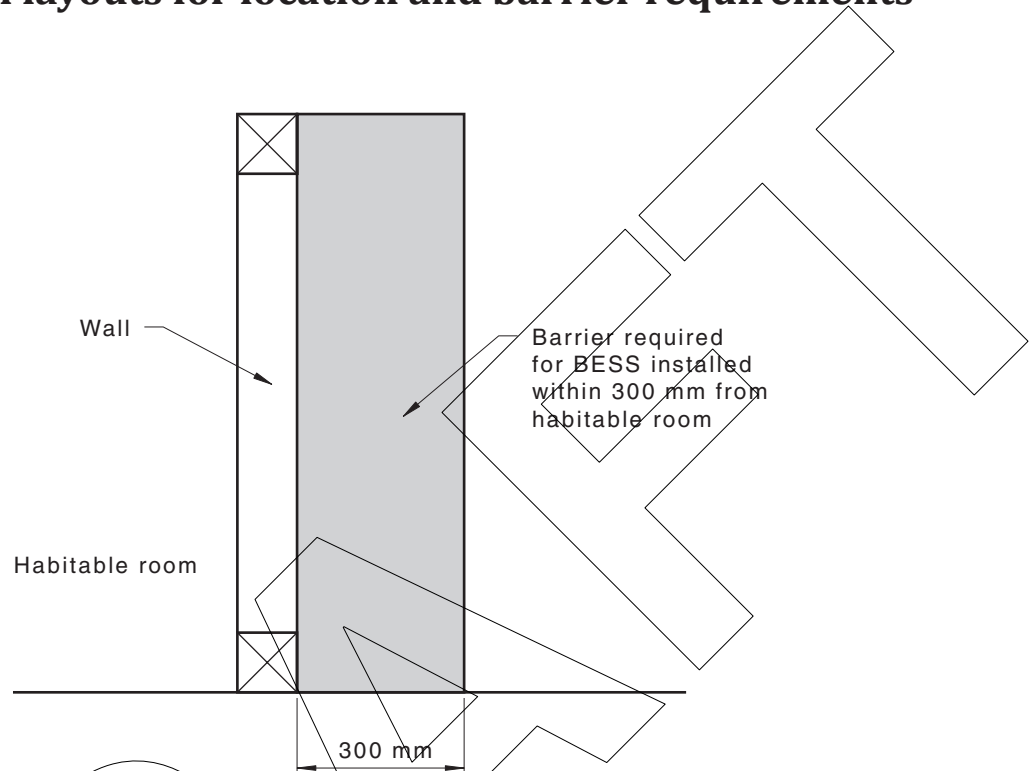

Figure E.1 — Ground-mounted separated by a distance from habitable room: side view of battery system or BESS in accordance with [Clauses 4.2.4.2, 5.2.4.2 and 6.2.4.2](#)



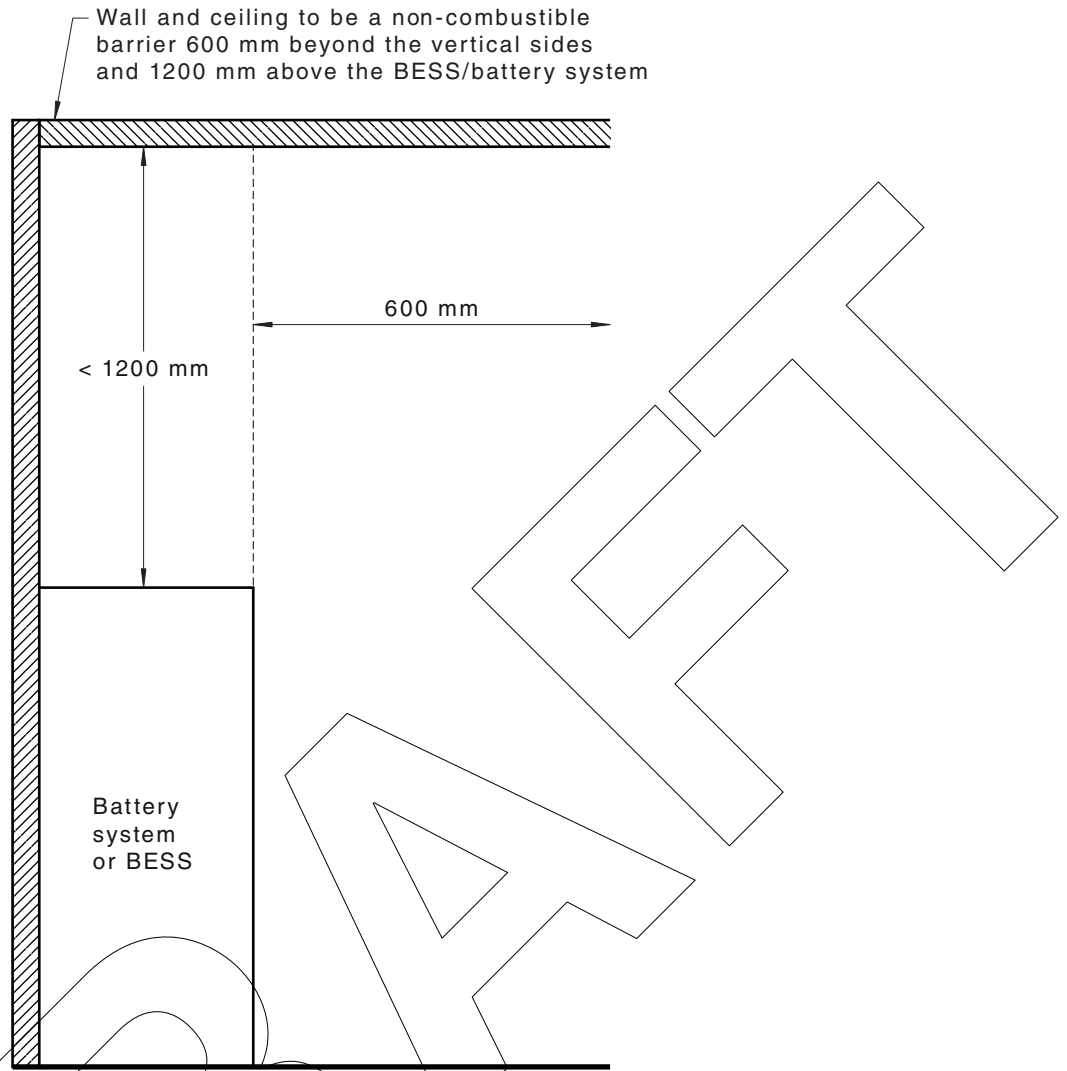

Figure E.2 — Ground-mounted next to wall against habitable room: side view of battery system or BESS in accordance with [Clauses 4.2.4.2, 5.2.4.2 and 6.2.4.2](#)

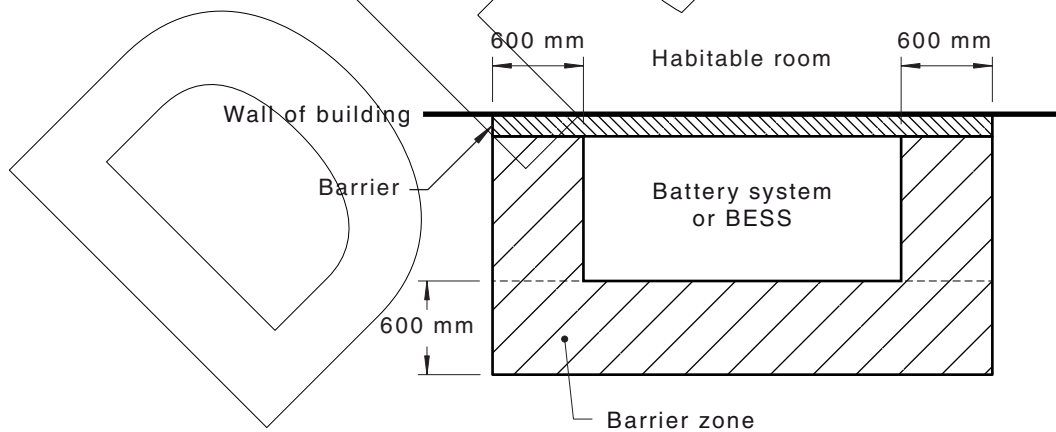
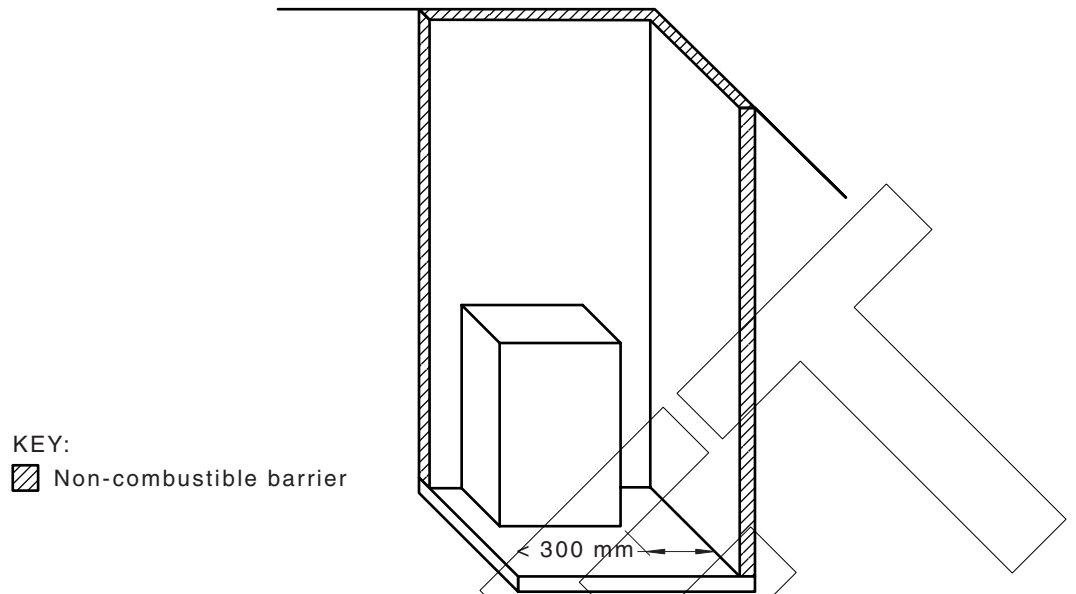

Figure E.3 — Ground-mounted: plan view of battery system or BESS in accordance with [Clauses 4.2.4.2, 5.2.4.2 and 6.2.4.2](#)

PUBLIC COMMENTING DRAFT



**Figure E.4 — Battery system or BESS installed in the corner**

## Appendix F (informative)

### Arc flash calculation

#### F.1 Overview

Arc flash occurs when electrical current passes through the air between electrified conductors when there is insufficient isolation or insulation to withstand the applied voltage.

Currently NFPA 70E, published by the US National Fire Protection Association is the only international standard that provides guidance on d.c. arc flash. NFPA 70E Annex D summarizes calculation methods for calculating arc flash incident energy and arc flash boundaries. Two methods for d.c. arcs are provided:

- Maximum power methodology (Doan method).
- Detailed arcing current and energy calculation method (Ammerman method).

While both methods are accepted by the industry, the two methods yield different results. The Doan method is more widely used since it is easier to calculate, but considered conservative in incident energy estimations. The Ammerman method is more detailed and accurate in the calculation of incident energy compared with Doan, however the Ammerman equations cannot be easily solved.

Due to its ease in calculations, the Doan Method is used in this Standard. Further information on this method can be obtained from the Paper: "Arc Flash Calculations for Exposures to DC Systems" by Daniel R Doan in the Publication: IEEE Transactions on Industry Applications, Volume 46 Number 6 November/December 2010.

The Doan formula for arc flash energy is provided below and it is then transposed to determine the arc flash boundary.

#### F.2 Arc flash incident energy

The arc flash incident energy for battery systems, having system voltages equal to or less than 1000 V d.c., is calculated using the following formula:

$$IE_m = 0.01 \times V_{sys} \times I_{arc} \times (T_{arc}/D^2) \times MF \quad F.1$$

where

$IE_m$  = estimated d.c. arc flash incident energy at the maximum power point in cal/cm<sup>2</sup>

$V_{sys}$  = system voltage in volts

$I_{arc}$  = arcing current in amperes

$T_{arc}$  = arcing time in seconds

$D$  = working distance in centimetres

$MF$  = multiplying factor

while

$$I_{\text{arc}} = 0.5 \times I_{\text{bf}}$$

where

$$I_{\text{bf}} = \text{battery system prospective fault (short circuit) current in amps}$$

### F.3 Arc flash incident protection boundary

The arc flash protection boundary is the distance at which incident energy equals 5 J/cm<sup>2</sup> (1.2 cal/cm<sup>2</sup>).

The arc flash protection boundary can be determined using the following equation:

$$\text{AFB} = \sqrt{(0.0083 \times V_{\text{sys}} \times I_{\text{arc}} \times T_{\text{arc}} \times MF)}$$

or

$$\text{AFB} = \sqrt{\left(\left(0.01 \times V_{\text{sys}} \times I_{\text{arc}} \times T_{\text{arc}} \times MF\right) / 1.2\right)}$$

where

AFB = arc flash protection boundary in centimetres

$V_{\text{sys}}$  = system voltage in volts

$I_{\text{arc}}$  = arcing current in amperes

$T_{\text{arc}}$  = arcing time in seconds

$MF$  = multiplying factor

while

$$I_{\text{arc}} = 0.5 \times I_{\text{bf}}$$

where

$$I_{\text{bf}} = \text{battery system prospective fault (short circuit) current in amps}$$

### F.4 Example calculations

#### EXAMPLE 1 No fusing within the string

A 48 V battery system has a prospective fault current of 6 kA. There is no fusing within the battery string. When there is no string fusing, assume that the arcing time is 2 s.

Assume:

- The working distance is 45 cm.
- The system is located in an enclosure with a multiplying factor of 3.

$$I_{\text{arc}} = 0.5 \times I_{\text{bf}}$$

F.3

$$= 0.5 \times 6000 \text{ A}$$

$$= 3000 \text{ A}$$

The arc flash incident energy is:

$$I_{Em} = 0.01 \times V_{sys} \times I_{arc} \times (T_{arc}/D^2) \times MF$$

$$= 0.01 \times 48 \times 3000 \times (2/452) \times 3$$

$$= 4.27 \text{ cal/cm}^2$$

The arc flash protection boundary is:

$$AFB = \sqrt{\left( \frac{0.01 \times V_{sys} \times I_{arc} \times T_{arc} \times MF}{1.2} \right)}$$

$$= \sqrt{\left( \frac{0.01 \times 48 \times 300 \times 2 \times 3}{1.2} \right)}$$

$$= 84.85 \text{ cm}$$

EXAMPLE 2 Fusing within the string

This example uses the same system details as for Example 1, however this system has string fusing. The arc flash time would equal the clearing time by the fuse for the prospective fault current of 6000 A. This would be obtained by referring to the arcing time graphs for the particular fuse being used. For this example, assume it is 0.1 s, although in reality it would be less than this, possibly as low as 0.01 s.

The arc flash incident energy is:

$$I_{Em} = 0.01 \times V_{sys} \times I_{arc} \times (T_{arc}/D^2) \times MF$$

$$= 0.01 \times 48 \times 3000 \times (0.1/452) \times 3$$

$$= 0.213 \text{ cal/cm}^2$$

The arc flash boundary is:

$$AFB = \sqrt{\left( \frac{0.01 \times V_{sys} \times I_{arc} \times T_{arc} \times MF}{1.2} \right)}$$

$$= \sqrt{\left( \frac{0.01 \times 48 \times 3000 \times 0.1 \times 3}{1.2} \right)}$$

$$= 18.9 \text{ cm}$$

Tables F.1 to F.4 provide incident arc flash energy and arc flash boundary distance for various voltages and fault current levels with and without inter-string protection.

F.4

F.5

F.6

F.7

**Table F.1 — Arc flash incident energy and arc flash protection boundary distances for 24 V battery systems**

Inter-string protection (see Note)	DC arc voltage	Bolted Fault current at point of activity	Arcing time	Multiplying factor	Incident energy	Arc flash boundary
	V					
No	24	3	2	3	1.067	42.43
	24	6	2	3	2.133	60.00
	24	9	2	3	3.200	73.48
	24	12	2	3	4.267	84.85
	24	15	2	3	5.333	94.87
	24	18	2	3	6.400	103.92
	24	21	2	3	7.467	112.25
	24	24	2	3	8.533	120.00
	24	27	2	3	9.600	127.28
	24	30	2	3	10.667	134.16
Yes	24	3	0.1	3	0.053	9.49
	24	6	0.1	3	0.107	13.42
	24	9	0.1	3	0.160	16.43
	24	12	0.1	3	0.213	18.97
	24	15	0.1	3	0.267	21.21
	24	18	0.1	3	0.320	23.24
	24	21	0.1	3	0.373	25.10
	24	24	0.1	3	0.427	26.83
	24	27	0.1	3	0.480	28.46
	24	30	0.1	3	0.533	30.00

NOTE Bolted faults at the terminals to the battery system (prior to fusing or circuit-breaker protection) can be significantly reduced by inserting inter-string protection.

**Table F.2 — Arc flash incident energy and arc flash protection boundary distances for 48 V battery systems**

Inter-string protection (see Note)	DC arc voltage	Bolted fault current at point of activity	Arcing time	Multiplying factor	Incident energy	Arc flash boundary
	V					
No	48	3	2	3	2.133	60.00
	48	6	2	3	4.267	84.85
	48	9	2	3	6.400	103.92
	48	12	2	3	8.533	120.00
	48	15	2	3	10.667	134.16
	48	18	2	3	12.800	146.97
	48	21	2	3	14.933	158.75
	48	24	2	3	17.067	169.71
	48	27	2	3	19.200	180.00
	48	30	2	3	21.333	189.74

**Table F.2 (continued)**

Inter-string protection (see Note)	DC arc voltage	Bolted fault current at point of activity	Arcing time	Multiplying factor	Incident energy	Arc flash boundary
	V				cal/cm <sup>2</sup>	cm
Yes	48	3	0.1	3	0.107	13.42
	48	6	0.1	3	0.213	18.97
	48	9	0.1	3	0.320	23.24
	48	12	0.1	3	0.427	26.83
	48	15	0.1	3	0.533	30.00
	48	18	0.1	3	0.640	32.86
	48	21	0.1	3	0.747	35.50
	48	24	0.1	3	0.853	37.95
	48	27	0.1	3	0.960	40.25
	48	30	0.1	3	1.067	42.43

**Table F.3 — Arc flash incident energy and arc flash protection boundary distances for 120 V battery systems**

Inter-string protection	DC arc voltage	Bolted fault current at point of activity	Arcing time	Multiplying factor	Incident energy	Arc flash boundary
	V				cal/cm <sup>2</sup>	cm
No	120	3	2	3	5.333	94.87
	120	6	2	3	10.667	134.16
	120	9	2	3	16.000	164.32
	120	12	2	3	21.333	189.74
	120	15	2	3	26.667	212.13
	120	18	2	3	32.000	232.38
	120	21	2	3	37.333	251.00
	120	24	2	3	42.667	268.33
	120	27	2	3	48.000	284.60
	120	30	2	3	53.333	300.00
Yes	120	3	0.1	3	0.267	21.21
	120	6	0.1	3	0.533	30.00
	120	9	0.1	3	0.800	36.74
	120	12	0.1	3	1.067	42.43
	120	15	0.1	3	1.333	47.43
	120	18	0.1	3	1.600	51.96
	120	21	0.1	3	1.867	56.12
	120	24	0.1	3	2.133	60.00
	120	27	0.1	3	2.400	63.64
	120	30	0.1	3	2.667	67.08

PUBLIC COMMENTING DRAFT



**Table F.4 — Arc flash incident energy and arc flash protection boundary distances for 350 V battery systems**

Inter-string protection	DC arc voltage	Bolted fault current at point of activity	Arcing time	Multiplying factor	Incident energy	Arc flash boundary
	V				cal/cm <sup>2</sup>	cm
No	350	3	2	3	15.556	162.02
	350	6	2	3	31.111	229.13
	350	9	2	3	46.667	280.62
	350	12	2	3	62.222	324.04
	350	15	2	3	77.778	362.28
	350	18	2	3	93.333	396.86
	350	21	2	3	108.889	428.66
	350	24	2	3	124.444	458.26
	350	27	2	3	140.000	486.06
	350	30	2	3	155.556	512.35
Yes	350	3	0.1	3	0.778	36.23
	350	6	0.1	3	1.556	51.23
	350	9	0.1	3	2.333	62.75
	350	12	0.1	3	3.111	72.46
	350	15	0.1	3	3.889	81.01
	350	18	0.1	3	4.667	88.74
	350	21	0.1	3	5.444	95.85
	350	24	0.1	3	6.222	102.47
	350	27	0.1	3	7.000	108.69
	350	30	0.1	3	7.778	114.56

The tables above illustrate that the addition of appropriate inter-string and battery system terminal protection can significantly influence the level of incident energy potential from an arc event.

### F.5 Effects by different faults

The calculations above and the [Tables F1 to F4](#) are all based on the fault occurring where the battery system voltage is applied to the arc. [Figures F1 to F3](#) provide the actual voltages and currents that would be applied to the arc flash incident energy calculations for different types of faults for three scenarios:

- (a) [Figure F.1](#) — No protection.
- (b) [Figure F.2](#) — String protection.
- (c) [Figure F.3](#) — String and inter-string protection.

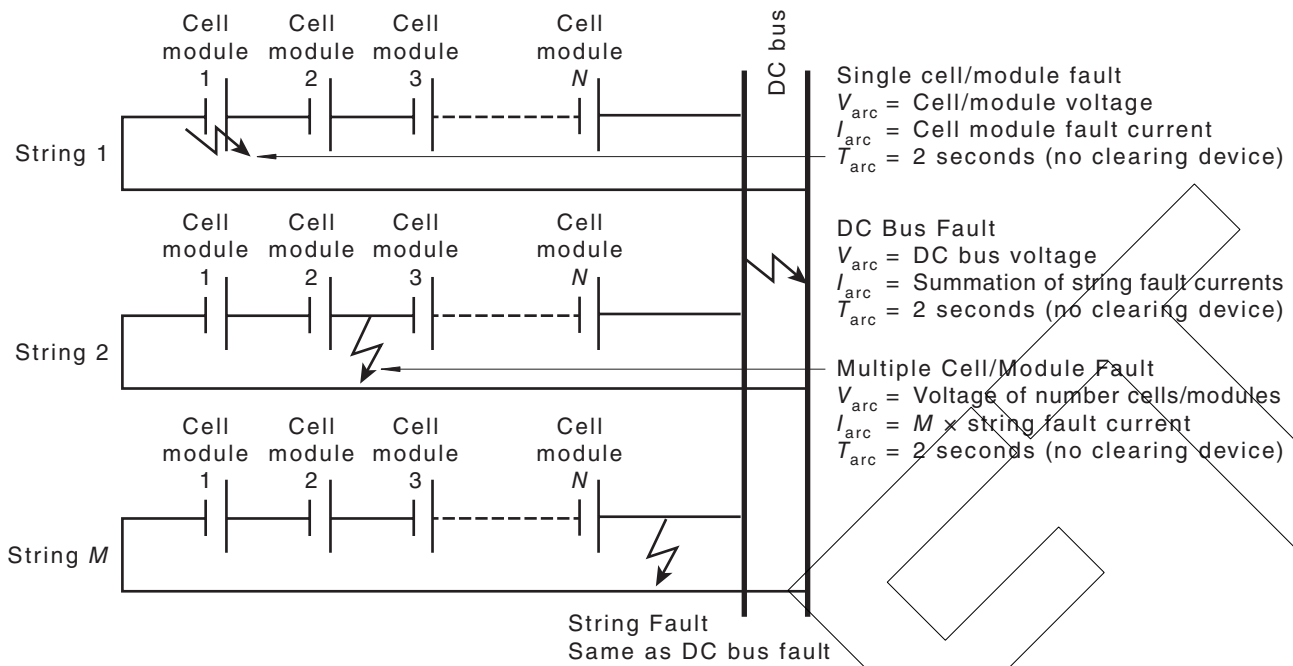

Figure F.1 — Examples of various faults with no protection

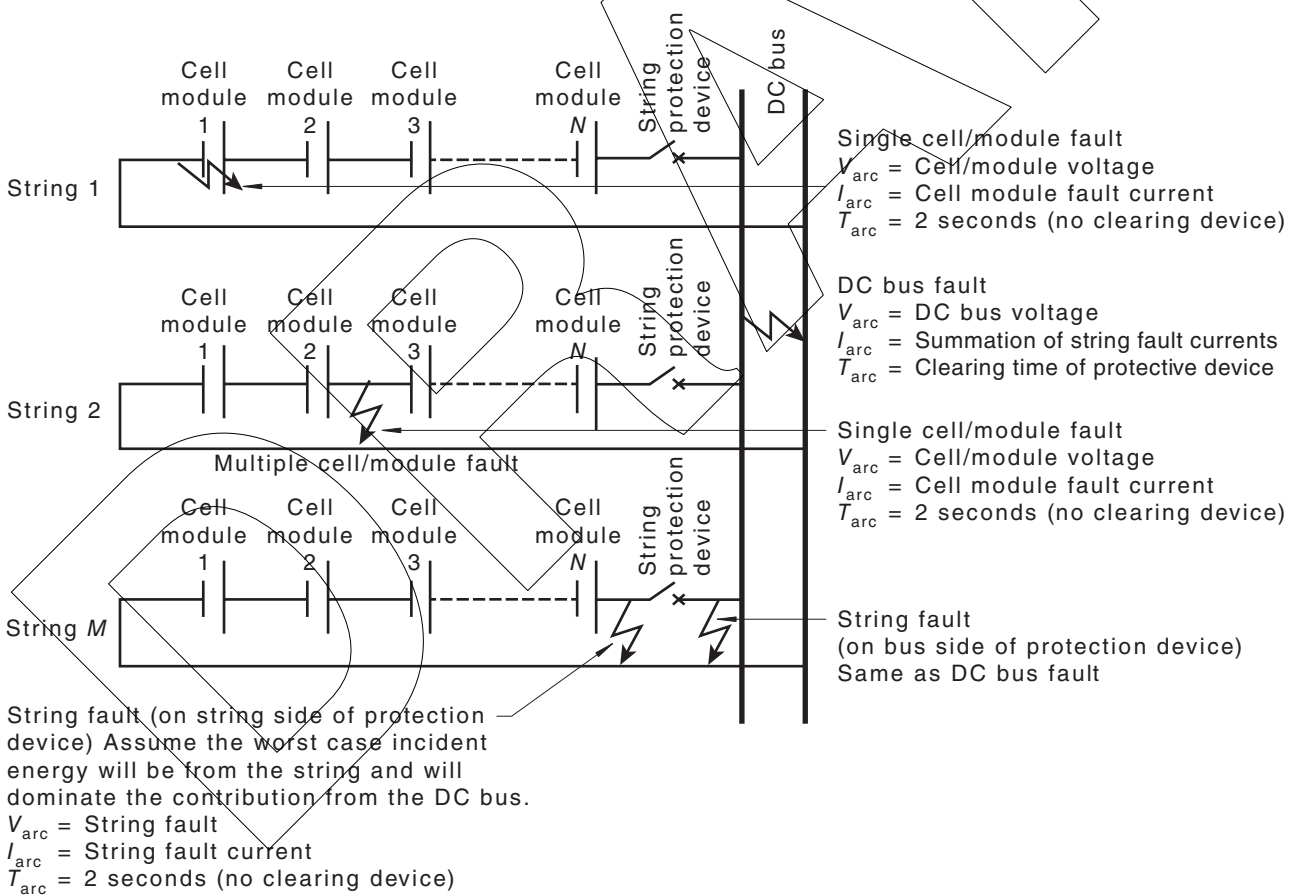
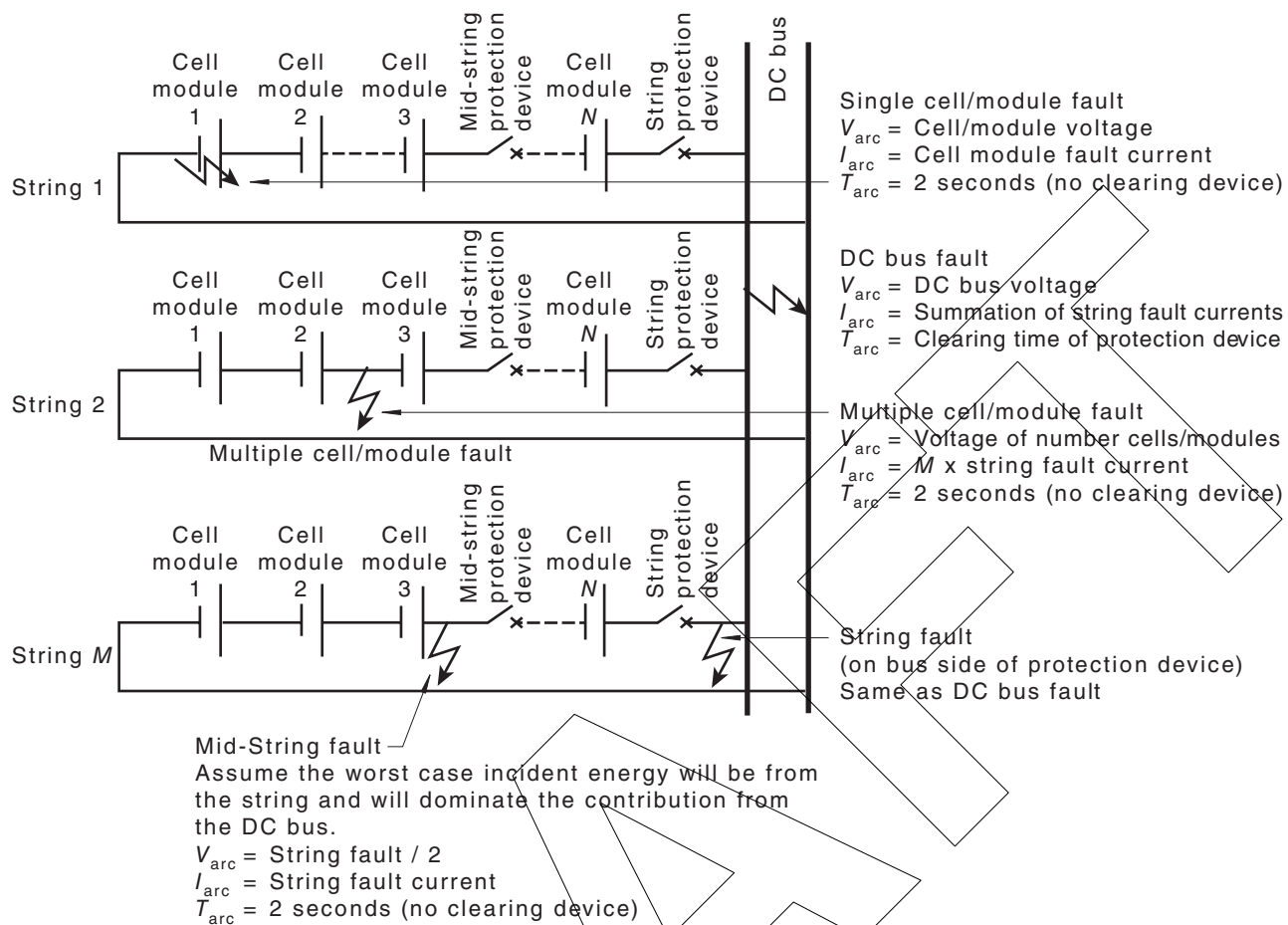

Figure F.2 — Examples of various faults with string protection

PUBLIC COMMENTING DRAFT



**Figure F.3 — Examples of various faults with string and inter-string protection**

PUBLIC COMMENTING DRAFT

## Appendix G (informative)

### Risk assessment

#### G.1 Safety risk assessment for BESS and battery systems

This Appendix provides guidance regarding a qualitative approach to risk assessment relating to the safety of BESSs and battery systems; to ensure not only that measures are put in place and considered as part of the safe installation of the BESS, but also for the life of the system. A risk assessment is an analytical process intended to ensure that safety hazards are properly identified and analysed with regard to their consequence and the likelihood of their occurrence. Appropriate protective measures can then be implemented and maintained. The risk assessment should include a comprehensive review of the hazards, and the protective measures that are required in order to maintain a tolerable level of risk including the following:

- (a) Identifying and analysing hazards.
- (b) Documenting identified hazards.
- (c) Determining the appropriate protective measures needed to reduce the level of risk to as low as reasonably practicable.

Risk assessment is a necessary factor at all stages of a battery system's life; design and installation, as well as operation, maintenance through to decommissioning. Appropriate information needs to be supplied by the customer, product manufacturers and suppliers for the risk assessment to be comprehensive. While this Standard covers typical hazards associated with a battery system or BESS, if there are other hazards particular to the location or the type of system being installed, these should also be included.

#### G.2 Risk assessment principles for battery systems

A hazard is any source of potential damage, harm or adverse health effects on a person, property of the environment. Hazards arise from the physical work environment, equipment and materials used, work tasks and how they are performed, work design and management. This Standard is specific to the hazards categorized in [Table 3.1](#) and installation requirements to mitigate these hazards. The safe work practices is not covered by this Standard.

A risk is the possibility or likelihood that harm might occur when exposed to the hazard and the severity of that harm. The risk is a measure of the consequence and the likelihood — the likelihood of injury, illness or damage to property or the environment arising from exposure to hazards. A risk assessment allows us to identify risks from hazards presented by a battery system and can be used to determine —

- (a) the severity of the risk;
- (b) whether existing control measures are effective; and
- (c) what action needs to be taken to control, monitor and review the risk.

Control measures are undertaken to reduce the risk to an acceptable level — as low as reasonably practicable. In battery systems and electrical systems it is not possible to eliminate all risks and prevention of people from making mistakes. Therefore applying as many control measures as reasonably practicable to minimize the potential for harm, balancing the implementation of controls against the benefits received in mitigating a risk to a level consistent with risk appetite or acceptability.

Once the control methods have been put in place, it is important to monitor and review implemented controls to evaluate their effectiveness.

Likelihood and consequence measures may be different for different situations and the requirements of a particular site may need to be incorporated into the risk assessment process. The consequence [Table G.1](#) is used as an example to grade the impact levels in relation to hazards. Each organization will need to evaluate the consequence type and impact level for each category of impact or consequence. [Table G.2](#) describes the levels of expected likelihood used for the purposes of this series of typical risk assessments. [Table G.1](#) and [Table G.2](#) should only be used as an example. Appropriate standards and guidelines are available for risk management (e.g AS/NZS ISO 31000).

PUBLIC COMMENTING DRAFT

DRAFT

Table G.1 — Typical risk consequence table

Consequence/ impact category	Consequence/impact rating definitions			
	Catastrophic	Major	Moderate	Minor
Health and safety	Any fatality of staff, contractor or public	Non-recoverable occupational illness or permanent injury	Injury or illness requiring medical treatment by a doctor	Injury requiring first aid
		Injury of illness requiring admission to hospital	Dangerous/reportable electrical incident	Circumstances that lead to a near miss
Environmental	High, long term or widespread impact (spill, emission, or habitat disturbance) to sensitive environment	Substantial impact — large spill or emission requiring Emergency Services attendance	Moderate impact — Spill or emission not contained on site with clean up needed	Minor cleanup/rectification — spill or emission not contained on site
	Environmental agency response with significant fine	Recovery of environment likely but not necessarily to pre-incident state	Death or destruction of protected flora or fauna	Environment expected to fully recover to pre-incident state
Legal and regulatory	Long term recovery of environment to pre-incident state not likely	Any spill into sensitive area (wet tropics, fish habitat, potable water supply)	Environment likely to recover to pre-incident state in short to medium term	Environmental nuisance (short-term impact) caused by noise, dust, odour, fumes, light
	Breach of licences, legislation or regulations leading to prosecution	Breach of legislation or regulations leading to: (a) contravention notice from authorities; (b) court order; or (c) fine over \$1000	Breach of legislation, regulations leading to: (a) warning/notice, or fine of up to \$1000; or (c) enforceable undertakings	Breach of legislation regulations, policies or guidelines leading to an administrative resolution
Asset impact	Equipment destruction, repair not possible, asset repair greater than original cost of works	Equipment damage repaired at a cost of between 50 % and 100 % of original cost of works	Equipment damage repaired at a cost of between 15 % and 50 % of original cost of works	Equipment damage repaired at a cost of between 2 % and 15 % of original cost of works
				Simple equipment damage with no or same day repair at a cost of less than 2 % of original cost of works
				No issues
				Clean up requires no special equipment and has no potential impact
				No or minor injury

[Table G.2](#) is provided as an example of definitions of likelihood of occurrence ratings.

**Table G.2 — Example likelihood of occurrence rating**

Likelihood rating	Definition of likelihood of occurrence rating
Almost certain	Probability of occurrence: greater than 90 %
	Expected to occur whenever system is accessed or operated
	The event is expected to occur in most circumstances
Likely	Probability of occurrence: 60 % - 89 %
	Expected to occur when system is accessed or operated under typical circumstances
	There is a strong possibility the event may occur
Possible	Probability of occurrence: 40 % - 59 %
	Expected to occur in unusual instances when the system is access or operated
	The event may occur at some time
Unlikely	Probability of occurrence: 20 % - 39 %
	Expected to occur in unusual instanced for non-standard access or non-standard operation
	Not expected to occur, but there is a slight possibility it may occur at some time
Rare	Probability of occurrence: 1 % - 19 %
	Highly unlikely to occur in any instance related to coming in contact with the system or associated systems
	Highly unlikely, but it may occur in exceptional circumstances, but probably never will.

And finally, the level of risk is a measure of the consequence and the likelihood. [Table G.3](#) demonstrates the outcome of these measures. Generally it would be recommended that where an inherent risk (a risk prior to the implementation of control measures) is greater than very low, that this risk be reviewed to determine what control measures can be put in place to reduce the risk (this is considered the residual risk). Residual risks that remain greater than "low" should be discussed with the system owner and operator and anyone involved in the installation of the system. The following risk matrix ([Table G.3](#)) may be used for the purposes of a risk assessment.

**Table G.3 — Risk matrix table**

Consequence (how serious)	Likelihood (how often)				
	Rare	Unlikely	Possible	Likely	Almost certain
Catastrophic	Medium	High	High	Extreme	Extreme
Major	Medium	Medium	High	High	Extreme
Moderate	Low	Medium	Medium	High	High
Minor	Very low	Low	Medium	Medium	Medium
Insignificant	Very low	Very low	Low	Medium	Medium

Adopted control measures should be the most effective options, starting with elimination and ending with personal protective equipment. The most effective way to manage a risk is to remove the risk entirely. As this is often not possible, the hierarchy of control measures suggest the next most appropriate methods of control. See [Figure G.1](#).



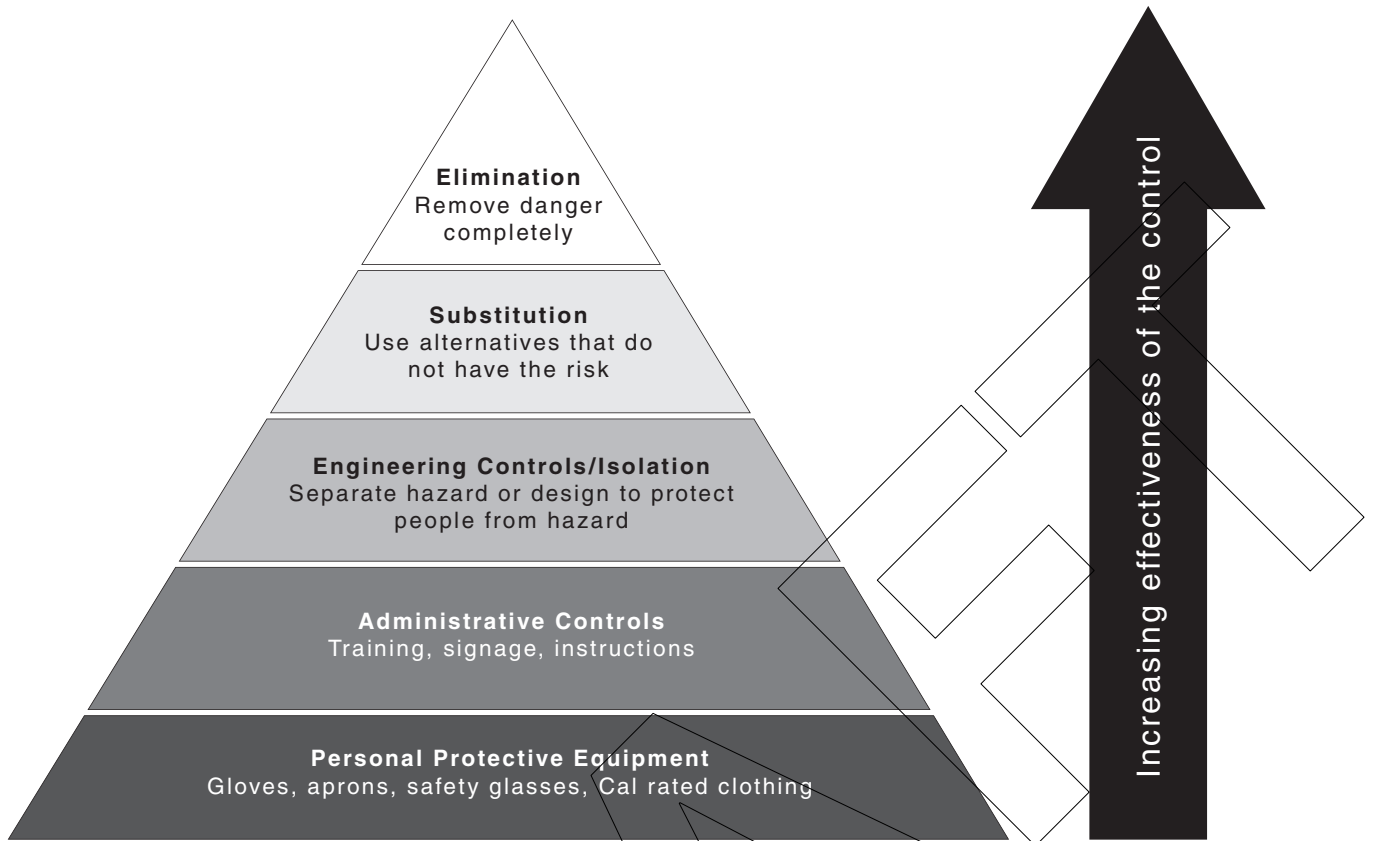

**Figure G.1 — Control measures and effectiveness**

To conduct the risk assessment for a BESS or battery system installation, a description of the BESS or battery system is required including general characteristics such as the following:

- (a) Battery chemistry, battery system voltage, short circuit current of the battery and battery system, DVC characteristics considerate of the PCE, operating options/modes of PCE.
- (b) Application type — Stand-alone or grid connected.
- (c) Installation — Location, environmental factors, enclosures, site.
- (d) Protection and isolation measures.

The risk assessments should deal with aspects of design, installation (including commissioning) and ongoing operation and maintenance, as each area may require specific risk controls.

**G.3 Risk assessment example — Stand-alone power supply for rural property**

An example for stand-alone power supply for rural property with the pertinent design parameters is provided in [Table G.4](#) to assess the risk assessment.

**Table G.4 — Example: Design parameters for a stand-alone power supply for rural property**

<b>Battery system installation:</b>	120 × 2 V VRLA battery cells (dimensions 180 mm (w) × 250 mm (d) × 700mm (h))
<b>Battery type:</b>	Valve regulated lead acid batteries (fire hazard level 2). No BMS or additional control other than the PCE is required. Voltage sense leads and two battery temperature monitoring leads are installed between the battery banks and the PCE.

PUBLIC COMMENTING DRAFT

Table G.4 (continued)

<b>Nominal system voltage:</b>	120 V
<b>Maximum system voltage:</b>	141 V (or 2.35 V per cell)
<b>Prospective short circuit current rating per string:</b>	6 kA
<b>PCE battery port rating:</b>	DVC-C
<b>Electrical connection:</b>	Two parallel strings each with 60 batteries
<b>Earthing:</b>	Floating battery bank, metal battery stands earthed
<b>Installation:</b>	Purpose built rooms in segregated part of shed (other areas are used for vehicles and a mechanical workshop) with lockable doors. There are no facilities for this shed to be a living space. The system is well within the boundaries of the property and at least 10 m away from the domestic dwellings on the site. Both rooms are protected from weather and any direct sunlight, insulated to reduce heat gain from the exterior and with a concrete slab floor. The batteries are installed in a separate room from PCE equipment. Venting of battery room is directly to exterior. Inverter and solar regulator installed in the PCE room. Main single isolator between PCE and battery bank also installed in PCE room.
<b>Battery room:</b>	Metal frames (earthed) with wooden bases elevating battery bases away from concrete, access doors provide 1200 mm wide opening for ease of access for bringing trolley/pallet jack in. Walls and ceiling insulated (using reflective foil) to reduce heat variability. Venting is natural with vents having screens to reduce possibility for vermin to enter. Vent size calculations take into account reduced air movement due to input and output air screens and some potential dust build up. Batteries are mounted vertically, with central aisle, one string installed on each wall, batteries are 2 cells deep against each wall. Terminal covers are divided such that access is based on the 40 V blocks for servicing. The battery room walls and ceiling are lined with non-combustible materials. Lighting mounted above the aisles in the battery room. Racks do not have support sides due to additional risks that this raises in manual handling.
<b>Overall battery system enclosure weight:</b>	9600 kg
<b>String isolation:</b>	Using fuse switches for over current protection in each string and a single disconnect circuit breaker on the input to the PCE. Fuse switches mounted on wall in battery room below top of batteries
<b>Inter-string isolation</b>	Two inter-string isolators are installed per string dividing each string into 3 (voltage for each subset is 40 V nominal (47 V maximum)). Isolation mounted on battery frames, below top of batteries. Isolators are no-load isolators and are clearly labelled as such.
<b>Installation location</b>	Out of sun and weather, in regional Tasmania. Battery racks (including wooden base) mounted on concrete floor to keep batteries away from concrete thermal mass
<b>Arc flash considerations:</b>	Battery room multiplying factor of 1.5 Balance of systems room multiplying factor of 1 Arc flash potential per string 6.1 cal/cm <sup>2</sup> Fuse switch response time 0.05 s (max) Circuit breaker response time 0.02 s (max) –from time/current response curve particular to the chosen circuit breaker

PUBLIC COMMENTING DRAFT

**Table G.4** (continued)

<b>Specific design considerations for this installation:</b>	The PCE is mounted in an adjacent room to the battery room. The PCE is mounted directly on the wall to manufacturer’s requirements. Voltage drop ensures less than 2 % based on full rated inverter current and the potential for only one battery string to be operational Cabling to each system is of same impedance (same length and same size cable) System installed with good access for trolleys, forklifts and clearance for working
--	--

[Table G.5](#) comprises d.c. arc fault calculations considerate of the various access and activities possible for this system.

PUBLIC COMMENTING DRAFT

DRAFT

Table G.5 — Example: Lead acid battery arc fault scenarios

Work activity (see Figure G.2)	DC arc flash parameters		Maximum power method (doan)				Risk rating		Arc flash boundary	Arc flash PPE required?	Controls to implement	
	Detail of possible worst case fault contribution	DC arc voltage V	Bolted fault current at point of activity kA	Arcing time seconds	Multi-plying factor	Incident energy cal/cm <sup>2</sup>	Consequence	Likelihood				Risk
Fault 1 — Work external to battery room between system circuit breaker and PCE — possible d.c. bus short	Full fault current contribution from both strings. String fuses and system circuit breaker act to reduce arc fault incident energy	141	12.00	0.02	1	0.08	Insignificant	Unlikely	Very low	11.87 cm	No	Isolation of batteries by string fuses and system circuit breaker will remove risks when working external to the battery room. Where live work is required, circuit breaker and fusing provides significant protection from arc fault. Standard electrical practices should be used. No specific further arc flash mitigation controls required in this room. While working external to battery room, doors to battery room should remain closed.
Fault 2 — Work external to battery room between system circuit breaker and battery room cable entries	Full fault contribution from both strings. String fuses act to reduce arc fault incident energy	141	12.00	0.05	1	0.20	Insignificant	Unlikely	Very low	18.77 cm	No	

Table G.5 (continued)

Work activity (see Figure G.2)	DC arc flash parameters		Maximum power method (doan)					Risk rating		Arc flash boundary	Arc flash PPE required?	Controls to implement
	Detail of possible worst case fault contribution	DC arc voltage	Boiled fault current at point of activity	Arcing time seconds	Multi-plying factor	Incident energy	Consequence	Likelihood	Risk			
Fault 3 — Work internal to battery room between battery room cable entries and string fuses	Fault contribution from both strings when strings are not isolated	141	12.00	0.05	1.5	0.30	Insignificant	Unlikely	Very low	22.99	No	Prior to commencement of work within the room, the system circuit breaker should be opened. Upon entering the room, the string fuses should be opened and then the inter-string isolators. To operate string fuse isolators within the room PPE level 2 is required. Where live work is required as there is no ability to rule out worst case faults, PPE level 2 is required. Insulated tools must be used. Standard electrical practices should be used.
Fault 4 — Work internal to battery room on load side of string fuses — Possible connection between two battery strings	Requires two faults to exist and dependent where these fault are, the worst case is depicted	141	12.00	0.05	1.5	0.30	Insignificant	Rare	Very low	22.99	No	
Fault 5 — Work internal to battery room on battery side of fuse — Possible d.c. bus short	Fault contribution from one battery system if no interstring isolators operated	141	6.00	2	1.5	6.08	Moderate	Rare	Low	102.83	Yes	
Fault 6 — Work internal to enclosure on battery side of fuse isolator, assuming inter-string isolators open	Fault contribution from smaller segment of system	47	6.00	2	1.5	2.03	Minor	Unlikely	Low	59.37	Yes	

Table G.5 (continued)

DC arc flash parameters	Maximum power method (doan)				Risk rating		Arc flash boundary	Arc flash PPE required?	Controls to implement
	Detail of possible worst case fault contribution	DC arc voltage	Bolted fault current at point of activity	Arcing time seconds	Multi-plying factor	Incident energy			
Work activity (see <a href="#">Figure G.2</a> )									
Fault 7 — Work internal to enclosure and cell fault or short across cell terminals occurs	Fault contribution only individual cell	2.35	6.00	2	1.5	0.10	Insignificant	Unlikely	Very low
							13.28	No	

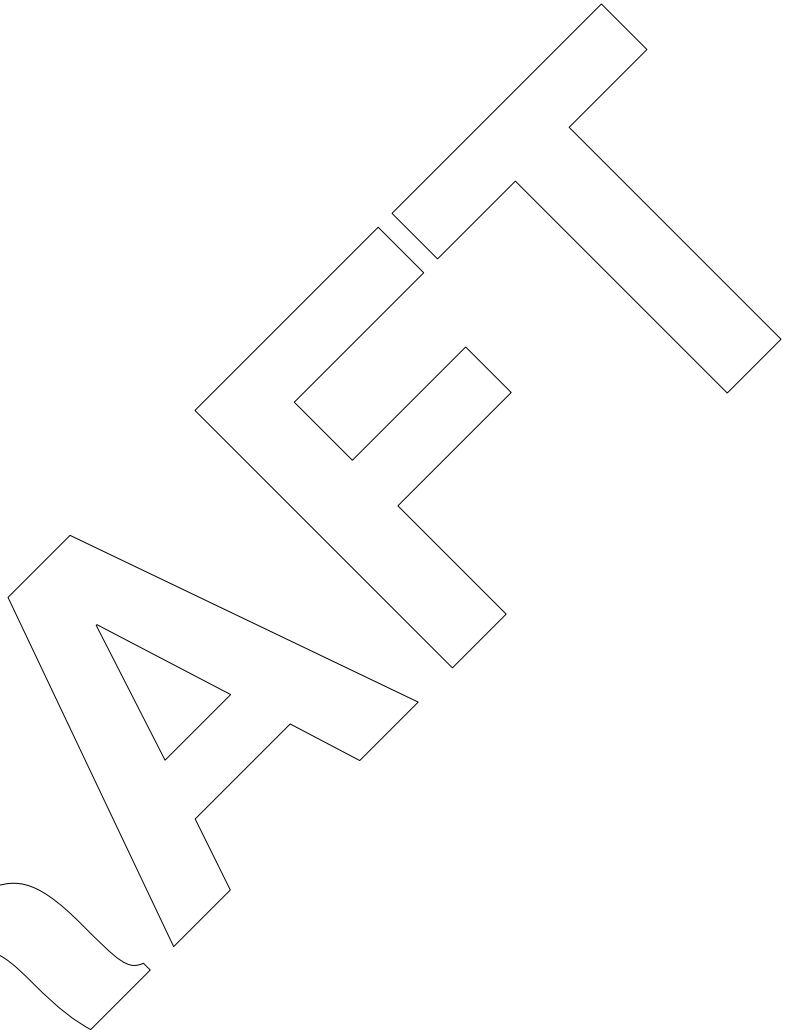

Even though, in the Example, shorting between the terminals of the 2 V lead acid battery cell (Fault 7) is not considered a significant arc flash risk, this does not suggest that there are no risks. If bare hands are used with uninsulated tools and a terminal short occurs; as the hands are generally within the arc flash boundary distance (in this case 13 cm distance), the impact can be considerable requiring first aid or hospitalization. As such, minimum PPE such as gloves and insulated tools are always required for battery work, regardless of the voltage or prospective short circuit current.

Figure G.2 provides a typical circuit diagram showing the battery connections and potential scenarios for arc flash as described in Table G.5.

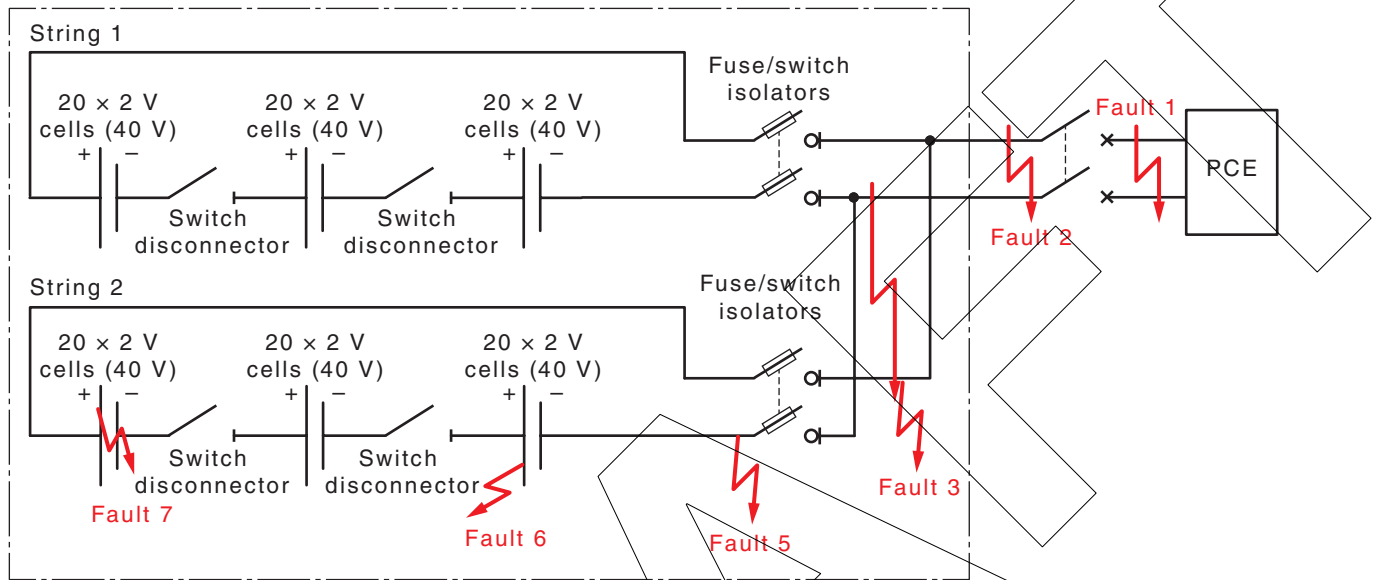

Figure G.2 — Example: Typical configuration and possible d.c. arc fault scenarios



## Appendix H (informative)

### Inspection and maintenance

#### H.1 General

The documentation provided in the system manual will be a valuable resource in determining maintenance and inspection tasks. The maintenance of battery systems is a consideration for the system owner on how best to manage their assets. As a minimum the manufacturer's instruction should be followed. Manufacturer's warranties may depend on evidence of maintenance being performed as specified in the manufacturer documentation.

#### H.2 Inspection

Regular inspections may identify issues or changes in the battery system that indicate the need for maintenance or remedial work. Regular inspections against a checklist will help identify maintenance actions. Inspections and maintenance tasks records provide a valuable resource and care should be taken to maintain these records.

The inspections checklist may include items such as inspection and review of —

- (a) battery system enclosure;
- (b) access to the battery system;
- (c) battery system ventilation;
- (d) labels, signage and documentation;
- (e) changes in surrounding environment that may affect the system temperature or accessibility;
- (f) any damage or deterioration to the enclosure or housing;
- (g) the online systems or system readouts for battery state of health or battery voltages; or
- (h) visual and audible alarms functioning and status.

#### H.3 Maintenance

##### H.3.1 General

Proper maintenance will prolong the life of a battery system and will help to ensure that it is capable of satisfying its design requirements. A suitable battery system maintenance program will serve as a valuable aid in determining the state of health of the battery and the need for battery replacement, or in locating system faults.

Maintenance set out in system documentation should be carried out according to the timetable provided in the system documentation. All maintenance and corrective actions are to be recorded within the system owner's documentation.

Maintenance should be carried out in accordance with the following:

- (a) The manufacturer's requirements.

- (b) The product SDS.
- (c) The checklist and instructions provided in the system documentation.
- (d) Applicable safety requirements.

### H.3.2 Maintenance tasks

The following items are examples of maintenance tasks that may be applicable:

- (a) Review any system inspection checklists and take into account when planning maintenance procedures.
- (b) Clean around battery system enclosure — Ensure free from vermin and debris.
- (c) Ensure any battery system isolation devices operate safely and in accordance with their ratings.
- (d) Inspect cabling to ensure there is no damage.
- (e) Inspect all signage and labelling is in place.
- (f) Inspect any ventilation to ensure this is meeting requirements.
- (g) Review battery system operation and battery system state of health.
- (h) Inspect enclosure, battery cells or modules for any deformities or signs of extreme temperatures.
- (i) Review any system logs (on line or via host computer) to review any abnormal operation.
- (j) Check operation of any alarms.
- (k) Perform periodic maintenance on mechanical devices (fans or pumps).
- (l) Update safety data sheet (SDS) to ensure information contained is current and in any instance all details is up to date with contact details, and is replaced with latest version at least every 5 years.
- (m) Review battery system in relation to other changes that may have taken place on site and how this may influence system performance and system safety.
- (n) Update, review, test or certify any firefighting or fire detection devices installed as part of the battery system as required under legislation or to meet requirements of manufacturer.
- (o) Check battery system voltages.
- (p) Check battery system's terminals for secure connection and for any terminal growth, discolouration or corrosion.
- (q) Thermal tests of d.c. switches and d.c. connections.
- (r) Perform a battery system test cycle.
- (s) Clean battery cells or modules.
- (t) Review battery system operation and battery system state of health.
- (u) Inspect for electrolyte leakage, ruptured vents, and discolouration of the battery case, terminals and leads.
- (v) Review torque of battery cell or module connections.
- (w) Review specific gravity of battery cells or modules.
- (x) Perform battery cell or module impedance tests.
- (y) Review any spill containment devices.

- (z) Review the alarm system logs of the battery management system or other monitoring system, where present, to determine whether there is a pattern of failure or misoperation emerging.

### H.3.3 Personal protective equipment

Follow the manufacturer's requirements for appropriate personal protective equipment (PPE) required for safe handling and maintenance of the battery system. Examples of PPE that may be required are as follows:

- (a) Combination overalls.
- (b) Dust coat.
- (c) Bib apron (PVC).
- (d) Boots (PVC or rubber).
- (e) Gloves (PVC fabric base).
- (f) Face shield or goggles.
- (g) Breathing apparatus.
- (h) Cal rated clothing to a suitable level (arc flash).

PUBLIC COMMENTING DRAFT

DRAFT

## Bibliography

- AS 1530.1, *Methods for fire tests on building materials, components and structures, Part 1: Combustibility test for materials*
- AS/NZS 3112, *Approval and test specification — Plugs and socket-outlets*
- AS/NZS ISO 31000, *Risk management — Principles and guidelines*
- IEC 60707, *Flammability of solid non-metallic materials when exposed to flame sources — List of test methods*
- IEC 60695-11-10, *Fire hazard testing, Part 11-10: Test flames — 50 W horizontal and vertical flame test methods*
- IEC 60695-11-20, *Fire hazard testing, Part 11-20: Test flames — 500 W flame test methods*
- ISO 9772, *Cellular plastics — Determination of horizontal burning characteristics of small specimens subjected to a small flame*
- ISO 9773, *Plastics — Determination of burning behaviour of thin flexible vertical specimens in contact with a small-flame ignition source*
- SAA/SNZ HB 76, *Dangerous Goods — Initial Emergency Response Guide*
- NCC, *National Construction Code*. Australian Building Code Board.
- NZBC, *New Zealand Building Code*
- Safe Work Australia. *Workplace exposure standards for airborne contaminants* Available from: <https://www.safeworkaustralia.gov.au/system/files/documents/1705/workplace-exposure-standards-airborne-contaminants-v2.pdf>
- NFPA 70E, *Standard for Electrical Safety in the Workplace*. National Fire Protection Association, USA.

Australian/New Zealand Standards are prepared by a consensus process involving representatives nominated by organizations drawn from major interests associated with the subject. Australian/New Zealand Standards may be derived from existing industry Standards, from established international Standards and practices or may be developed within a Joint Technical committee.

Committee EL-042, Renewable Energy Power Supply Systems and Equipment, consisting of the following, is responsible for the issue of this draft:

- Australasian Fire and Emergency Service Authorities Council
- Australian Energy Council
- Australian Energy Market Operator
- Australian Industry Group
- Australian PV Institute
- Clean Energy Council
- Clean Energy Regulator
- Communications, Electrical and Plumbing Union - Electrical Division
- Construction, Environment and Workplace Protection, ACT Government
- Consumer Electronics Suppliers Association
- Consumers Federation of Australia
- CSIRO
- Electrical Compliance Testing Association of Australia
- Electrical Regulatory Authorities Council
- Electrical Safety New Zealand
- Electricity Engineers Association, New Zealand
- Energy Networks Australia
- Engineers Australia
- Institute of Electrical and Electronics Engineers
- Institute of Electrical Inspectors
- Joint Accreditation System of Australia and New Zealand
- Master Electricians Australia
- National Electrical and Communications Association
- NSW Fair Trading



GPO Box 476 Sydney NSW 2001  
**Phone** (02) 9237 6000  
**Email** [mail@standards.org.au](mailto:mail@standards.org.au)  
**Internet** [www.standards.org.au](http://www.standards.org.au)  
**SAI Global Customer Service**  
**Phone** 13 12 42  
**Email** [sales@saiglobal.com](mailto:sales@saiglobal.com)



PO Box 1473 Wellington 6140  
**Freephone** 0800 782 632  
**Phone** (04) 498 5990  
**Email** [enquiries@standards.govt.nz](mailto:enquiries@standards.govt.nz)  
**Website** [www.standards.govt.nz](http://www.standards.govt.nz)

### **Standards Australia**

Standards Australia is an independent company, limited by guarantee, which prepares and publishes most of the voluntary technical and commercial standards used in Australia. These standards are developed through an open process of consultation and consensus, in which all interested parties are invited to participate. Through a Memorandum of Understanding with the Commonwealth government, Standards Australia is recognized as Australia's peak national standards body.

### **Standards New Zealand**

The first national Standards organization was created in New Zealand in 1932. The New Zealand Standards Executive is established under the Standards and Accreditation Act 2015 and is the national body responsible for the production of Standards.

### **Australian/New Zealand Standards**

Under a Memorandum of Understanding between Standards Australia and Standards New Zealand, Australian/New Zealand Standards are prepared by committees of experts from industry, governments, consumers and other sectors. The requirements or recommendations contained in published Standards are a consensus of the views of representative interests and also take account of comments received from other sources. They reflect the latest scientific and industry experience. Australian/New Zealand Standards are kept under continuous review after publication and are updated regularly to take account of changing technology.

### **International Involvement**

Standards Australia and Standards New Zealand are responsible for ensuring that the Australian and New Zealand viewpoints are considered in the formulation of international Standards and that the latest international experience is incorporated in national and Joint Standards. This role is vital in assisting local industry to compete in international markets. Both organizations are the national members of ISO (the International Organization for Standardization) and IEC (the International Electrotechnical Commission).

### **Visit our web sites**

[www.standards.org.au](http://www.standards.org.au)

[www.standards.govt.nz](http://www.standards.govt.nz)